

SE-300

KORG STAGE ECHO

取扱い説明書.....	P1
Owner's Manual.....	P6
Bedienungsanleitung.....	P11
Mode D'emploi.....	P16

●はじめに

この度は、コルグ ステージエコー SE-300をお求めいただき、ありがとうございました。
 ステージエコーSE-300は、プロフェッショナルエコーSE-500に、さらにリバーブが加えられた、ハイグレードなエコーマシンです。

オートパット方式により、1つのつまみで、スムーズに入力レベルの設定ができる上に、新しく加わったリバーブをフルに活用して、ダイレクト音だけにリバーブを効かせたり、エコーの再生音だけにリバーブを効かせるなど、従来のエコーマシンでは得られなかった様々な残響効果を創り出すことができます。

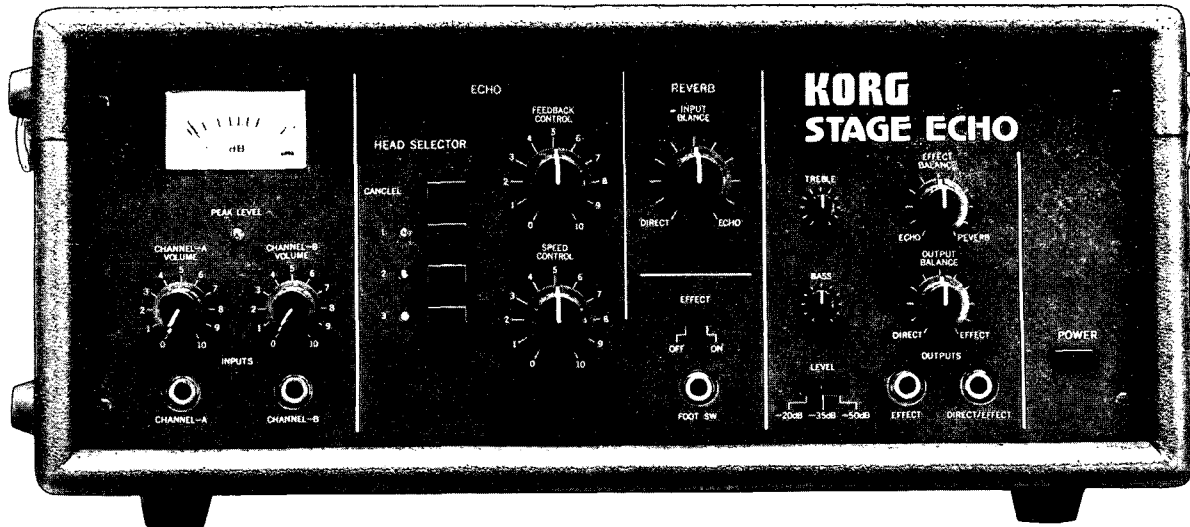

●ブロック図

下の図は、SE-300の各つまみと、入出力の関係を示したものです。

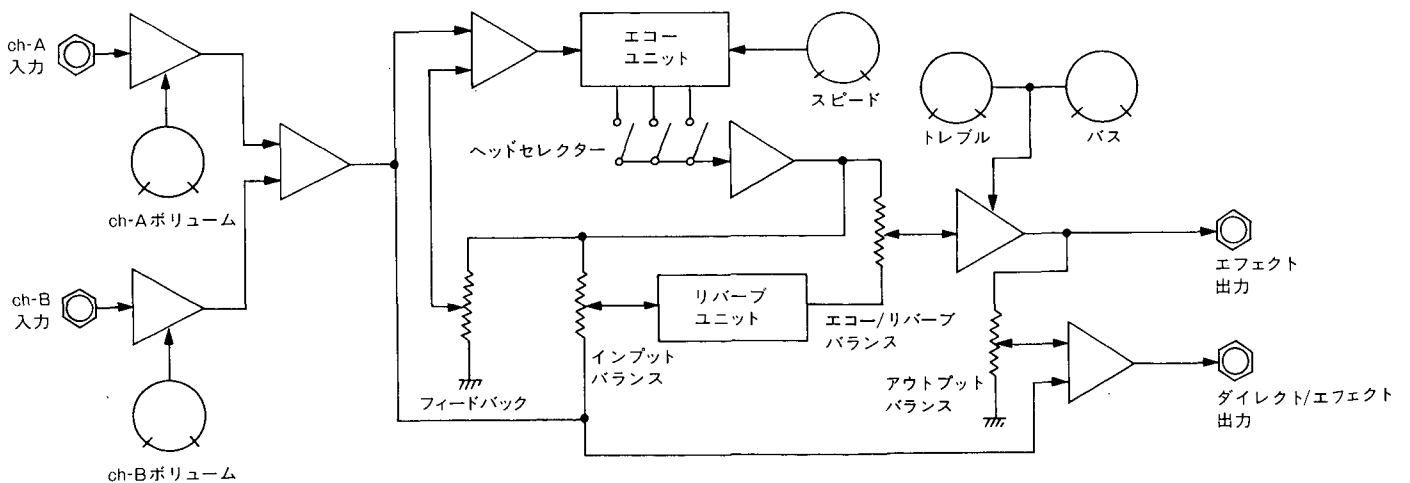

Introduction

Thank you for choosing the Korg Stage Echo SE-300. This advanced unit features reverb capability on top of the basic performance of the Korg SE-500 professional echo machine. Input level adjustment is easier than ever, thanks to the employment of the auto-pat system. In contrast to most

conventional units, the SE-300 also lets you add reverb to just the direct signal or just the echo playback signal. A wide variety of time-delay sound effects are yours with the Korg SE-300.

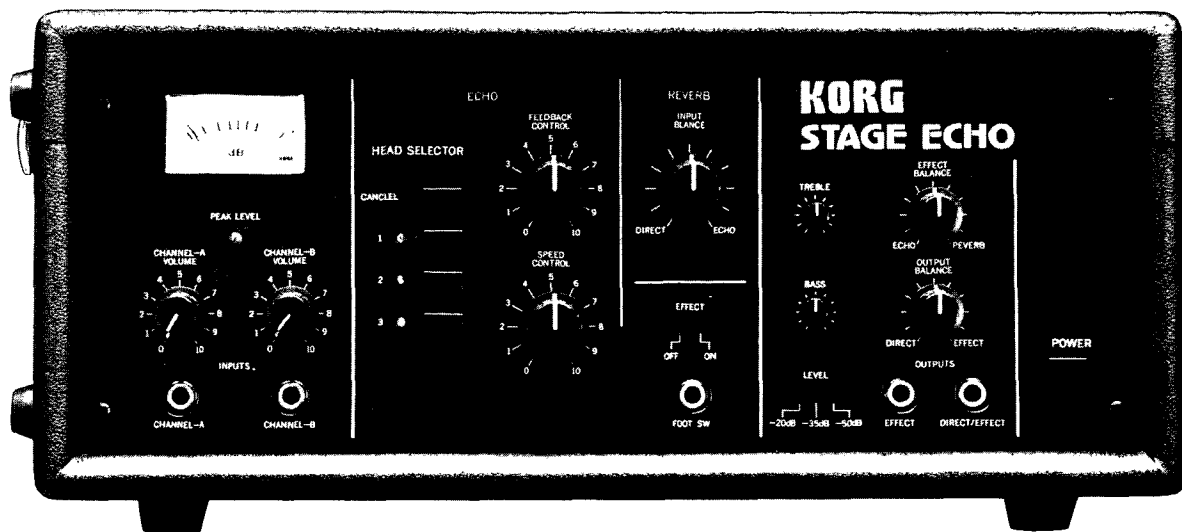

Block Diagram

The diagram below shows the relationships between the control knobs and input/output signals in the SE-300.

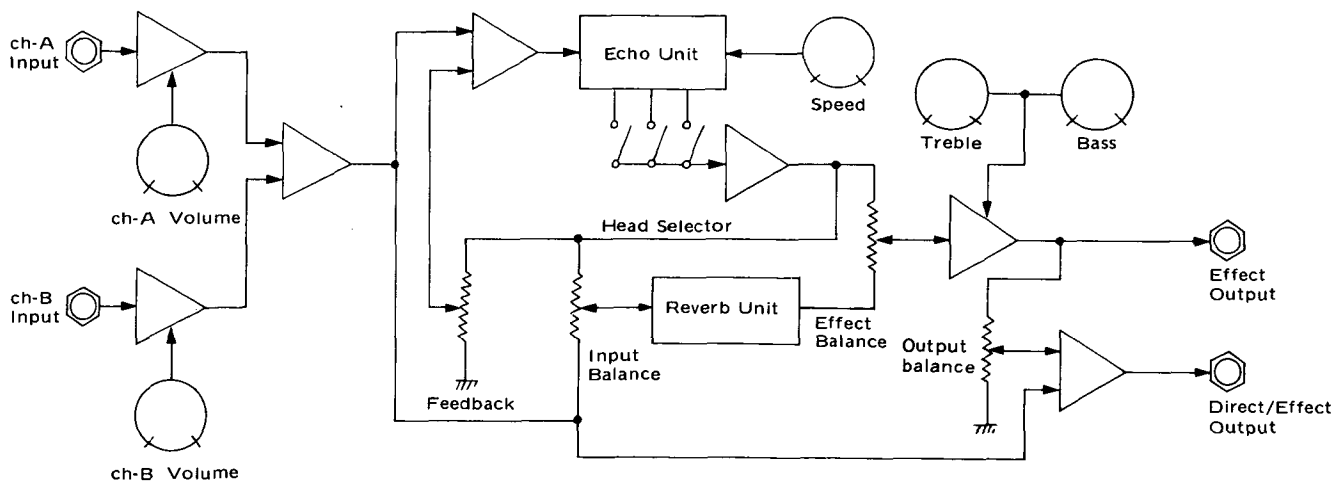

Features and Functions

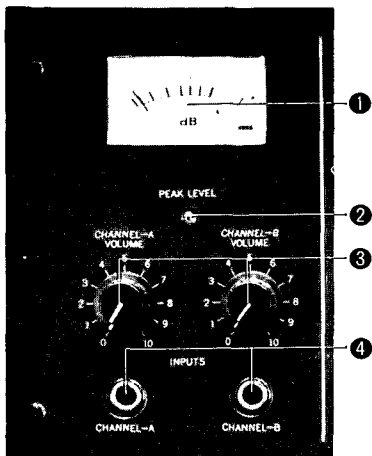

- 1 Input Level Meter:**
Use this meter to check input level. Adjust the volume knobs so that the meter reads between -5dB and 0dB when you play the loudest.
- 2 Peak level indicator:**
This LED peak level indicator gives accurate indications of instantaneous peak transients not shown by the averaging type input level meter. Since such peak transients are the main cause of distortion, turn down the volume knobs if the peak level indicator stays lit, rather than only flickering on and off occasionally.
- 3 Input volume:**
Use these knobs to adjust input level. While playing (or singing), watch the meter needle movement and the peak level indicator. For best sound quality, adjust the input volume knobs so that the meter indication stays between -5dB and 0dB when you play the loudest.
- 4 Input jacks:**
Plug your electric guitar, electronic instrument, or microphone cords into these jacks.

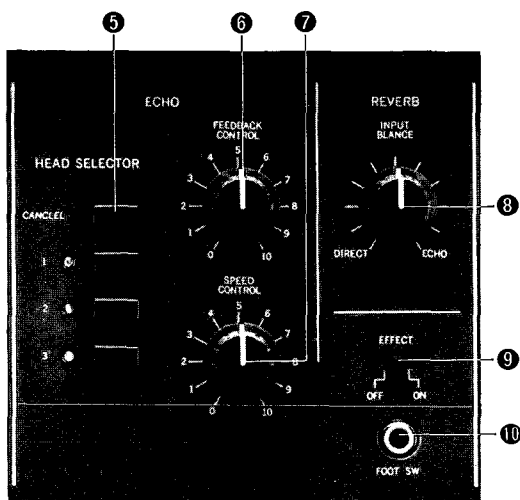

- 5 Head selectors:**
Press the cancel button to cancel all the heads when you don't want any echo effect. Press button "1" for a conventional echo effect. Press button "2" when you want a bit longer echo. Press button "3" for the longest echo effect having a maximum delay time of 1.2 seconds. By pressing two or more buttons at once, you can get more complex echo effects and "swell" effects.
- 6 Feedback control:**
Use this knob to control the number of times the echo is repeated. At "0" you will get just a single echo (one repeat). Note that if you set the knob to "7" or higher, oscillation will occur and the sound will keep on going without stopping.
- 7 Speed control:**
Use this knob to adjust the time delay between echos. After choosing the basic length of the echo effect by pressing one (or more) of the head selector buttons, use this speed control knob for fine adjustment of the delay time.
- 8 Reverb input balance control:**
Use this knob to adjust the relative amount of reverb applied to the direct sound signal and the echo playback signal. Set to the center position for a conventional echo-plus-reverb effect. Change the balance setting for more unusual time-delay effects. For reverb without echo, turn the knob all the way counterclockwise to the "Direct" position.
- 9 Effect switch:**
Use this switch when you want to temporarily cancel all time delay effects. Ordinarily this switch should be left in the "ON" position when using the echo machine. In the "OFF" position, both echo and reverb effects are defeated.

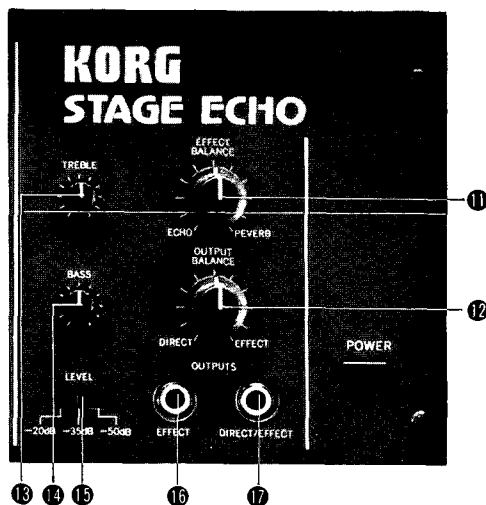

- 10 Foot switch jack:**
Connect a foot switch (Korg J-type) to this jack for foot-operated remote control of the effect switch above. Set the effect switch to the "ON" position when using a foot switch.
- 11 Effect balance control:**
Use this knob to adjust the balance between the echo and reverb effects. If you have pressed the head selector cancel button (so that there is no echo effect), you can use this knob to control the depth of the reverb effect. For accurate adjustment of balance when using both echo and reverb, turn the knob a little at a time from the echo side toward the reverb side until you get just the effect you want.
- 12 Output balance control:**
Use this knob for final adjustment of the balance between the direct signal and the effect signal (with the addition of echo and/or reverb). Note that this knob only affects the signal from the "DIRECT/EFFECT" jack. It does not influence the signal from the "EFFECT" jack.
- 13 Treble, 14 Bass:**
Use these knobs to adjust tone quality of the effect signal (with the addition of echo and/or reverb). For linear response, leave these knobs in the center positions.
- 15 Output level switch:**
Use this switch to select output signal level. Choose the output level appropriate to the input sensitivity of the amp or mixer you use. This switch controls the output level of both the "EFFECT" jack and the "DIRECT/EFFECT" jack at the same time.
- 16 Effect out:**
This jack gives you just the echo/reverb signal. Therefore, it is suited to connection to a mixer or other intermediate sound processing equipment.
- 17 Direct/effect out:**
This jack gives you the direct signal mixed with the echo/reverb signal. Use this jack for direct connection from the SE-300 to an amplifier.

Connections

Since the SE-300 employs the auto-pat system, you don't have to worry about the strength of the input signal. Just set the input volume knobs to "0" and plug your instruments and microphones into the input jacks. Then watch the level meter while playing, and turn up the volume knobs to a

suitable level.

Use the output level switch to choose the level appropriate the amp or other equipment connected to the SE-300 output jacks.

- 50 dB: For vocal amps, etc.
- 35 dB: For guitar and bass amps, etc.
- 20 dB: For mixers, etc.

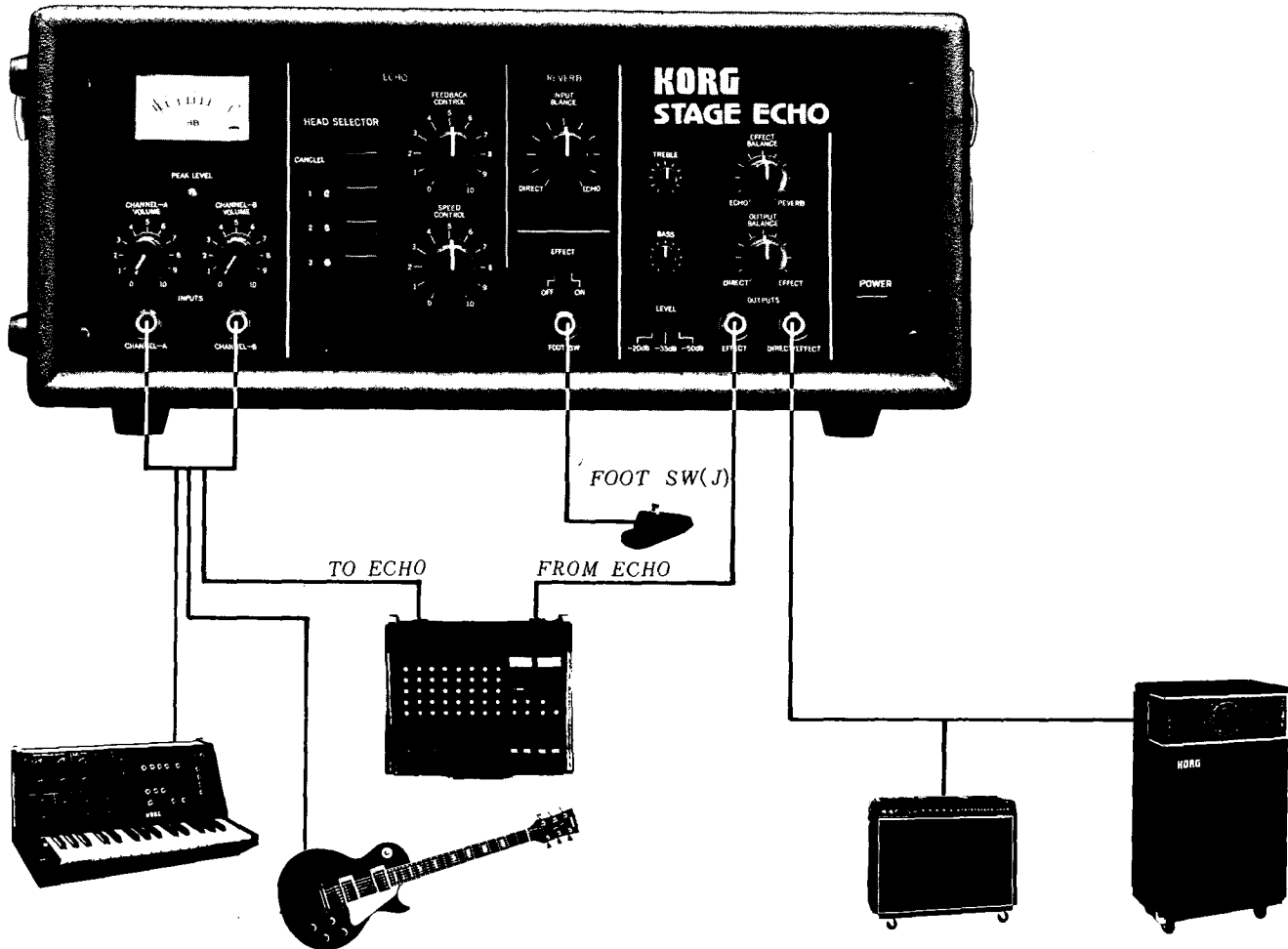

Setting charts

Vocals – This setting gives a natural sounding echo and reverb effect.

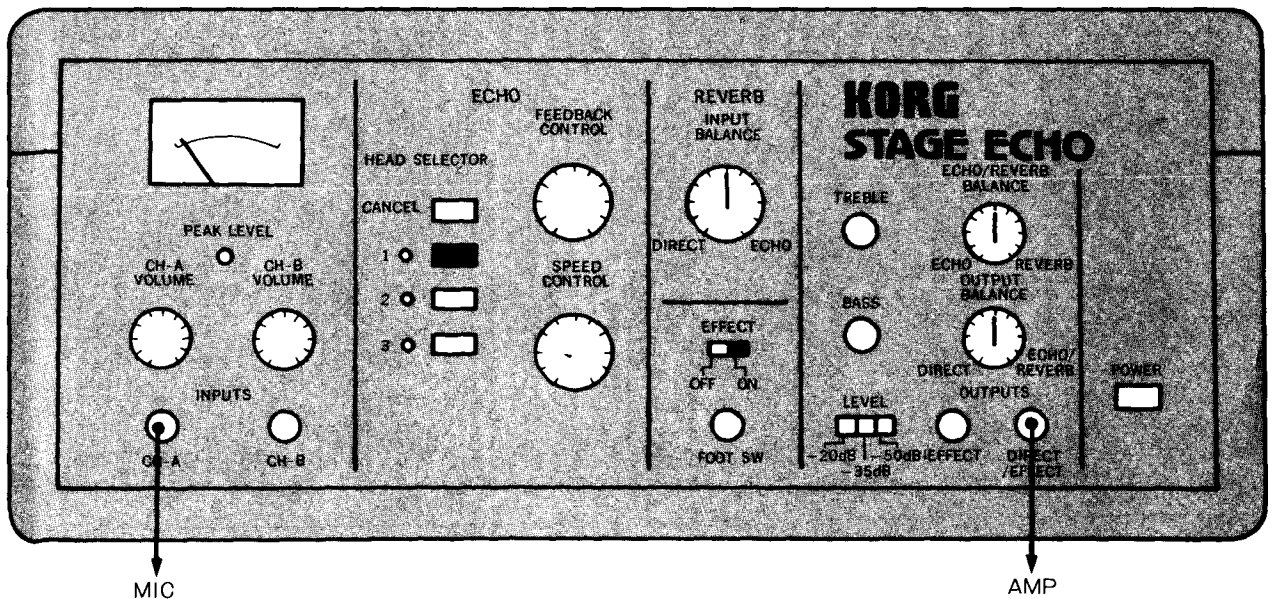

Echo alone – Use the knobs and buttons in the ECHO section to adjust the effect.

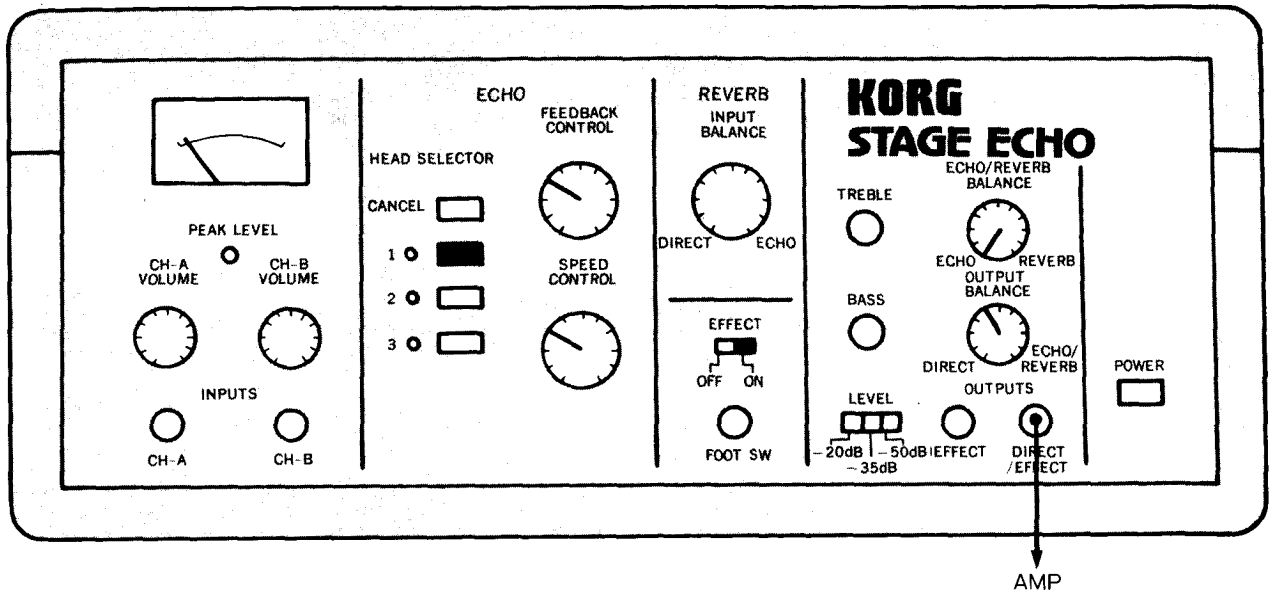

Reverb alone – For reverb without any echo.

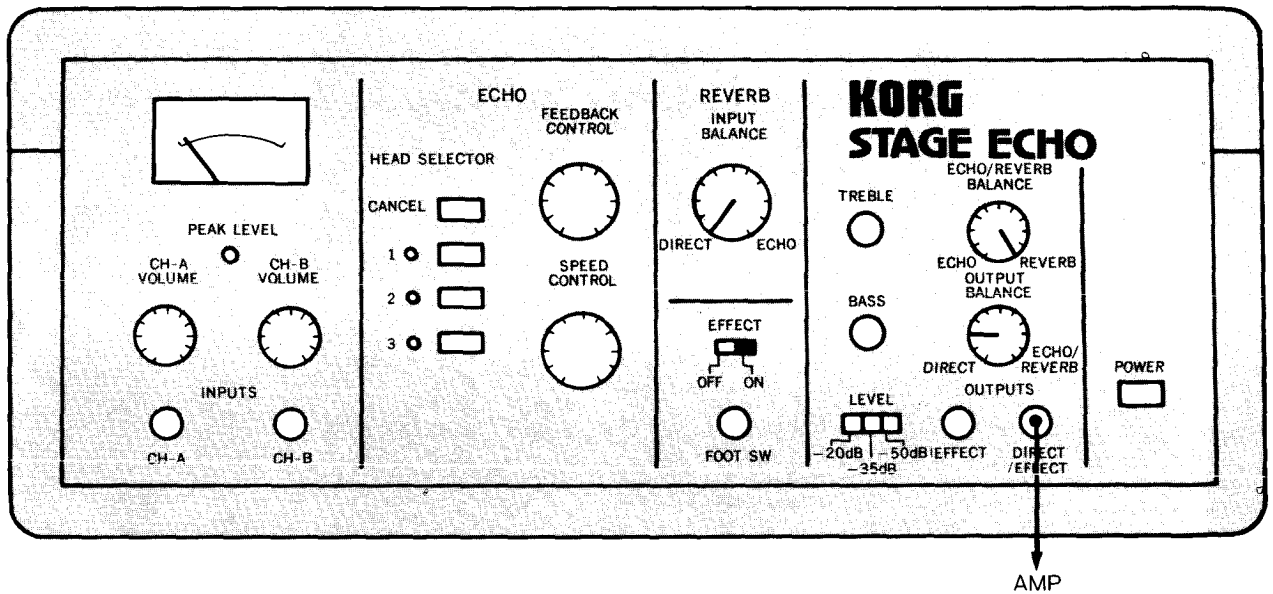

Complex special effect – The feedback control is at "0" for a single echo. Reverb is only applied to the echo signal. The echo time delay is about 1.2 seconds.

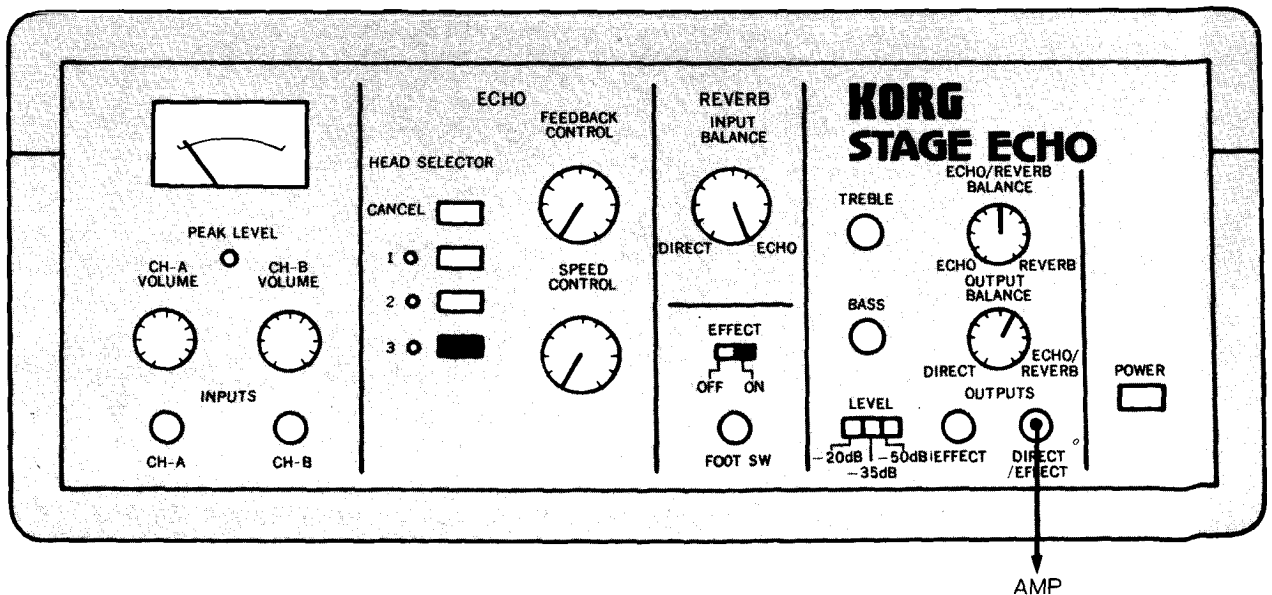

Replacing the cartridge tape

How to change the tape

1. Turn off the power
2. Loosen screw (A), unscrew the other four screws and remove the clear plastic cover.
3. Take out the old tape.
4. Clean the heads (B), pinch roller (C), capstan, and tape guides.
5. Place the SET-01 tape case in the position shown in the diagram.
6. Pull the end of the tape out of the SET-01 case and pass the loop around the heads (B) and pinch roller (C).
7. After threading the tape, put the plastic cover back on and screw in the four screws.
8. Turn on the power so that the tape is pulled completely out of the tape case.
9. Once the tape is out of the case, remove the SET-01 tape case and tighten screw (A) in its original position.
10. Run the tape for 5~10 minutes to loosen it up.

Caution

When changing the tape, be sure to clean the entire tape path including the heads and pinch roller.
Use of tape other than SET-01 may result in loss of performance.

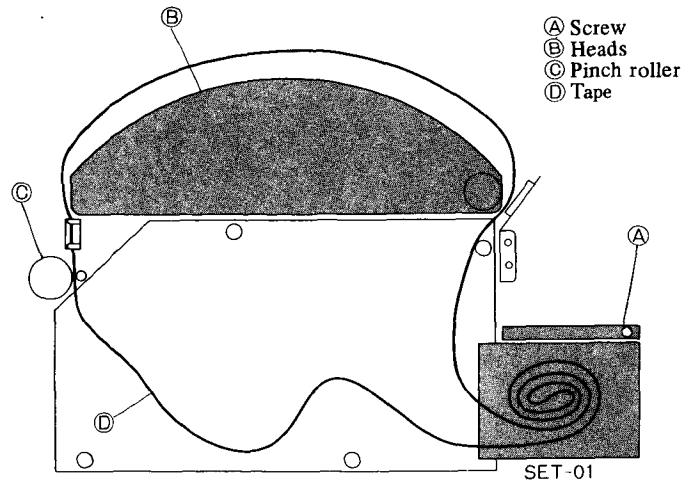

Caution

1. Do not store or use the unit where it will be subject to dust, dirt, high humidity or high temperature.
2. All heads must be cleaned regularly with head cleaning fluid or alcohol. Also clean capstan, pinch roller, and tape guides. Wait for all parts to dry before allowing tape contact with heads.
3. Do not oil or lubricate moving parts. No lubrication is needed, and it may cause deterioration of performance.
4. The endless tape loop will deliver optimum performance for about 300 hours of use. After that, performance will be reduced. Relace with SET-01 tape loop.
5. The SE-300 may pick up noise if placed too near other equipment. If this occurs, try changing the relative positions of the units. Also check the input signal for noise.

Specificatios

Inputs	Inputs (for mike, instruments etc.)2	Indicators	Level meter (VU type)1
	Effect Switch1		Peak Level Indicator (LED)1
Outputs	Effect Out1	Heads	Head Indicator (LED)3
	Direct/Effect Out1		Recording1
Control knobs	Input Volume2		Playback3
	Head Selector3		Erase1
	Feedback Control1	Dimintions	420(W) × 170(H) × 335(D)mm
	Speed Control1	Weight	12.3kg
	Reverb Inptu Balance1	Accessories	Foot Switch (J)1
	Effect Switch1		Connection Cord (3m)1
	Tone (Treble, Bass)2	Power Consumption	40W
	Effect Balance1		
	Output Balance1		
	Output Level Attenuator (-20/-35/-50dB)1		
	Power Switch1		

Einleitung

Wir möchten uns bei dieser Gelegenheit dafür bedanken, daß Sie sich für das Echogerät Korg Stage Echo SE-300 entschieden haben. Dieses fortschrittliche Gerät bietet zusätzliche Möglichkeiten zu den Grundeffekten der professionellen Echomaschine Korg SE-500.

Dank der Verwendung des "auto-pat"-Systems kann der

Eingangspegel äußerst einfach eingestellt werden. Im Gegensatz zu den meisten konventionellen Geräten läßt Modell SE-300 zusätzlichen Nachhall zu den direkten Signalen zu, oder es kann auch das einfache Echosignal abgespielt werden. Mit Modell SE-300 von Korg verfügen Sie auch über eine Vielzahl von Zeitverzögerungseffekten.

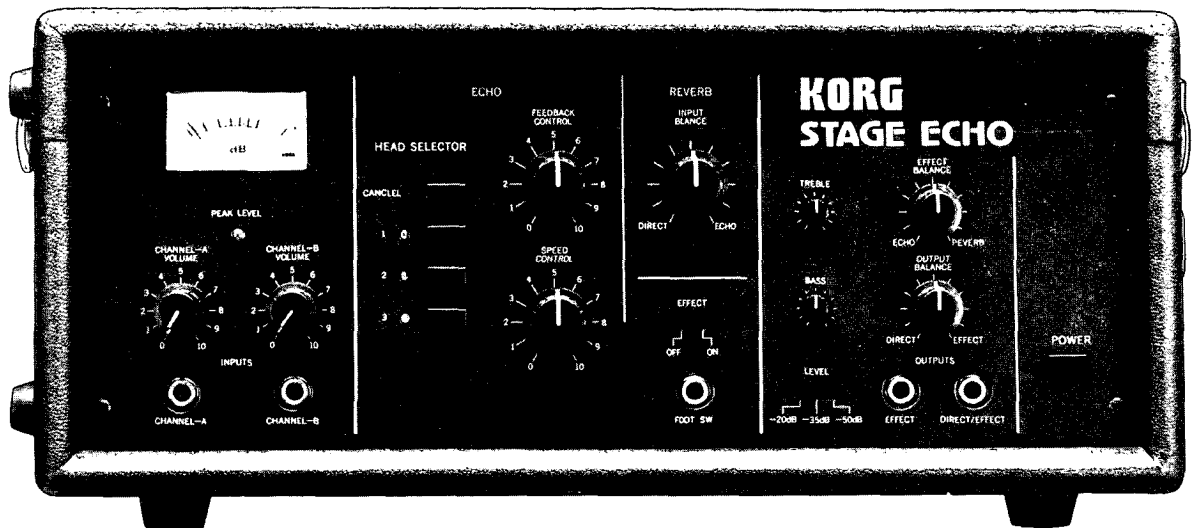

Blockschaltbild

Das nachfolgende Diagramm zeigt den Zusammenhang zwischen den Regelknöpfen und den Ein-/Ausgangssignalen von Modell SE-300.

