

KORG

PERFORMANCE SIGNAL PROCESSOR

A5

BASS

OWNER'S MANUAL

CONNECTION WITH BASS.....	3
PLAYING PRESET PROGRAMS [PROGRAM MODE].....	4
OPERATING INDIVIDUAL EFFECTS [MANUAL/EDIT MODE]..	5
CREATING ORIGINAL PROGRAMS [Manual/Edit Mode].....	6
SAVING EFFECTS [PROGRAM WRITE].....	8
OTHER USEFUL FUNCTIONS.....	9
EFFECT PARAMETER LIST.....	10

IMPORTANT SAFETY INSTRUCTIONS

WARNING : When using electric products, basic precautions should always be followed, including the following.

1. Read all the instructions before using the product.
2. To reduce the risk of injury, close supervision is necessary when a product is used near children.
3. Do not use this product near water – for example, near a bathtub, washbowl, kitchen sink, in a wet basement, or near a swimming pool, or the like.
4. This product, either alone or in combination with an amplifier and headphones or speakers, may be capable of producing sound levels that could cause permanent hearing loss. Do not operate for a long period of time at high volume level or at a level that is uncomfortable. If you experience any hearing loss or ringing in the ears, you should consult an audiologist.
5. The product should be located so that its location or position does not interfere with its proper ventilation.
6. The product should be located away from heat sources such as radiators, heat registers, or other products that produce heat.
7. The product should be connected to a power supply only of the type described in the operating instructions or as marked on the product.
8. The power – supply cord of the product should be unplugged from the outlet when left unused for a long period of time.
9. Care should be taken so that objects do not fall and liquids are not spilled into the enclosure through openings.
10. The product should be serviced by qualified service personnel when:
 - A. The power – supply cord or the plug has been damaged; or
 - B. Objects have fallen, or liquid has been spilled into the product; or
 - C. The product has been exposed to rain; or
 - D. The product does not appear to, operate normally or exhibits a marked change in performance; or
 - E. The product has been dropped, or the enclosure damaged.
11. Do not attempt to service the product beyond that described in the user – maintenance instructions. All other servicing should be referred to qualified service personnel.

Congratulations and thank you for purchasing the KORG A5 BASS Performance Signal Processor. To get the most out of this advanced instrument and enjoy it in its optimum condition for the longest possible time, please read this manual carefully, and keep it handy.

TABLE OF CONTENTS

NAMES AND FUNCTIONS OF CONTROLS AND TERMINALS	2	OTHER USEFUL FUNCTIONS	9
CONNECTION WITH BASS	3	1. Comparison with Preset Data	9
PLAYING PRESET PROGRAMS [PROGRAM MODE]	4	EFFECT PARAMETER LIST	10
OPERATING INDIVIDUAL EFFECTS [MANUAL/EDIT MODE]	5	1. COMPRESSOR [COMPRESSOR]	10
CREATING ORIGINAL PROGRAMS [Manual/Edit Mode]	6	2. 5 BAND EQ [5 BAND EQ]	10
UTILITY	7	3. DYNAMIC EXCITER [DYNA XCITE]	11
SAVING EFFECTS [PROGRAM WRITE]	8	4. CHORUS/FLANGER [CHORUS/FL]	11
		5. REVERB/DELAY [REV/DELAY]	12
		6. UTILITY	12
		ERROR MESSAGES	13
		TROUBLESHOOTING	13
		SPECIFICATIONS AND OPTIONS	14

THE FCC REGULATION WARNING

This equipment generates and uses radio frequency energy and if not installed and used properly, that is, in accordance with the manufacturer's instructions, may cause interference to radio and television reception. It has been type tested and found to comply with the limits for a class b computing device in accordance with the specifications in Subpart J of Part 15 of FCC Rules, which are designed to provide reasonable protection against such interference in a residential installation. However, there is no guarantee that interference will not occur in a particular installation. If this equipment does cause interference to radio or television reception, which can be determined by turning the equipment off and on, the user is encouraged to try to correct the interference by one of the following measures:

- Reorient the receiving antenna.
- Relocate the equipment with respect to the receiver.
- Move the equipment into a different outlet so that equipment and receiver are on different branch circuits.

If necessary, the user should consult the dealer or an experienced radio/television technician for additional suggestions. The user may find the following booklet prepared by the Federal Communications Commission helpful. "How to Identify and Resolve Radio - TV Interference Problems". This booklet is available from the US Government Printing Office, Washington D.C. 20402, stock No. 004 - 000 - 0003454.

CANADA

THIS APPARATUS COMPLIES WITH THE "CLASS B" LIMITS FOR RADIO NOISE EMISSIONS SET OUT IN RADIO INTERFERENCE REGULATIONS.

CET APPAREIL EST CONFORME AUX NORMES "CLASS B", POUR BRUITS RADIOELECTRIQUES. TEL QUE SPECIFIE DANS LE REGLEMENT SUR LE BROUILLAGE RADIOELECTRIQUE.

NAMES AND FUNCTIONS OF CONTROLS AND TERMINALS

FRONT PANEL

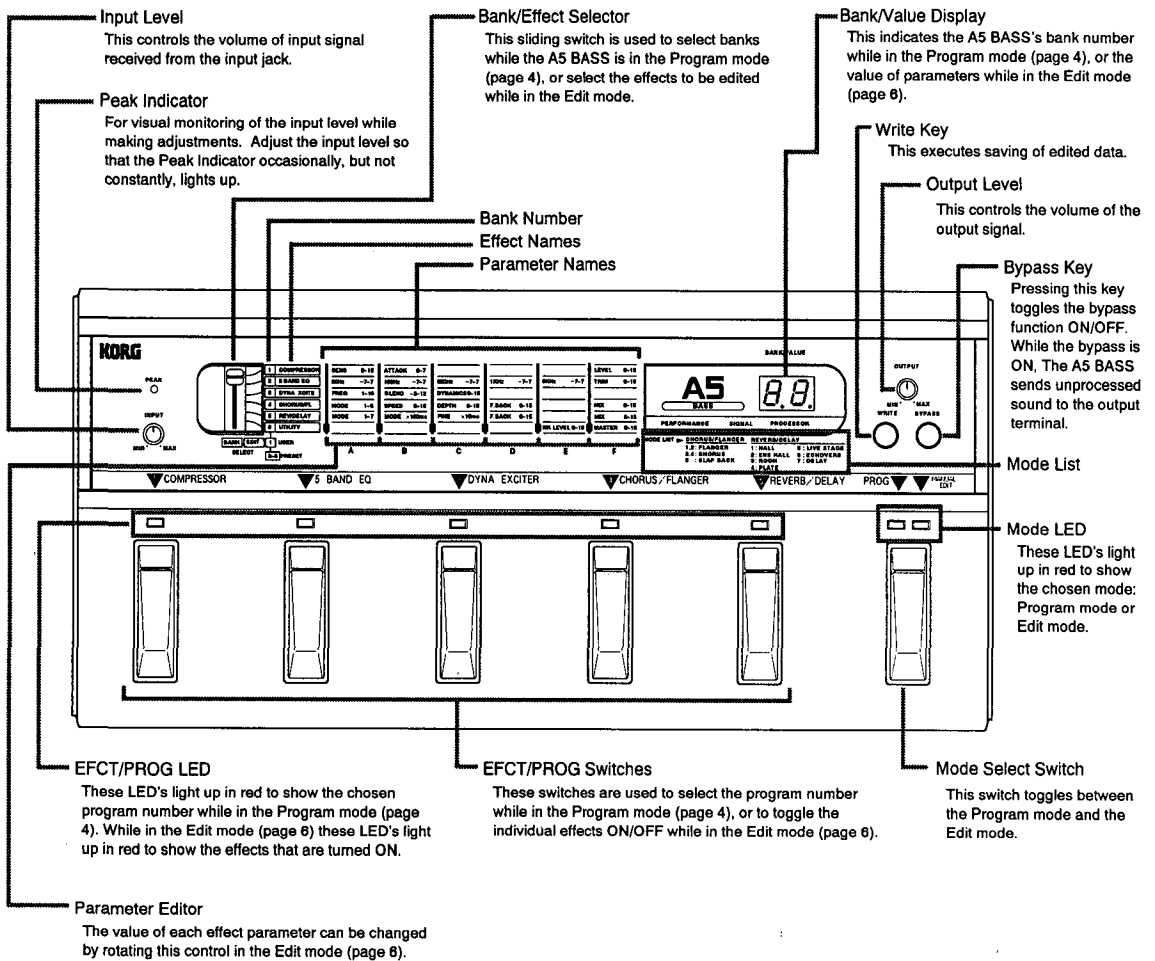

REAR PANEL

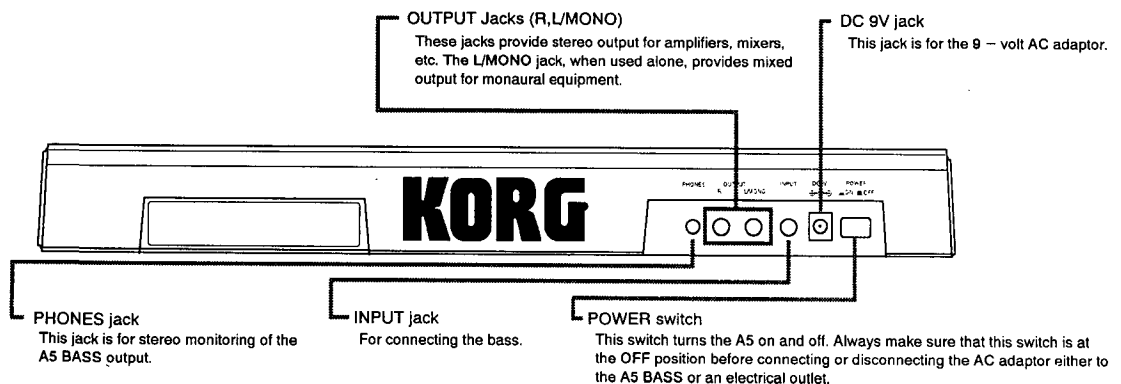

CONNECTION WITH BASS

1. Connect the bass to the INPUT jack on the rear panel.
2. Connect the bass amplifier to the OUTPUT jacks on the rear panel.
(For best results, use both jacks for stereo output. For monaural operation, connect to the L/MONO jack.)
3. Input signal can be monitored in stereo by connecting a pair of headphones to the PHONES jack.
4. After making connection with other instruments and equipment, turn on the A5 BASS's power.

NOTE : When turning on and off the A5 BASS, turn the volume controls on all instruments and equipment down – as far as they will go.

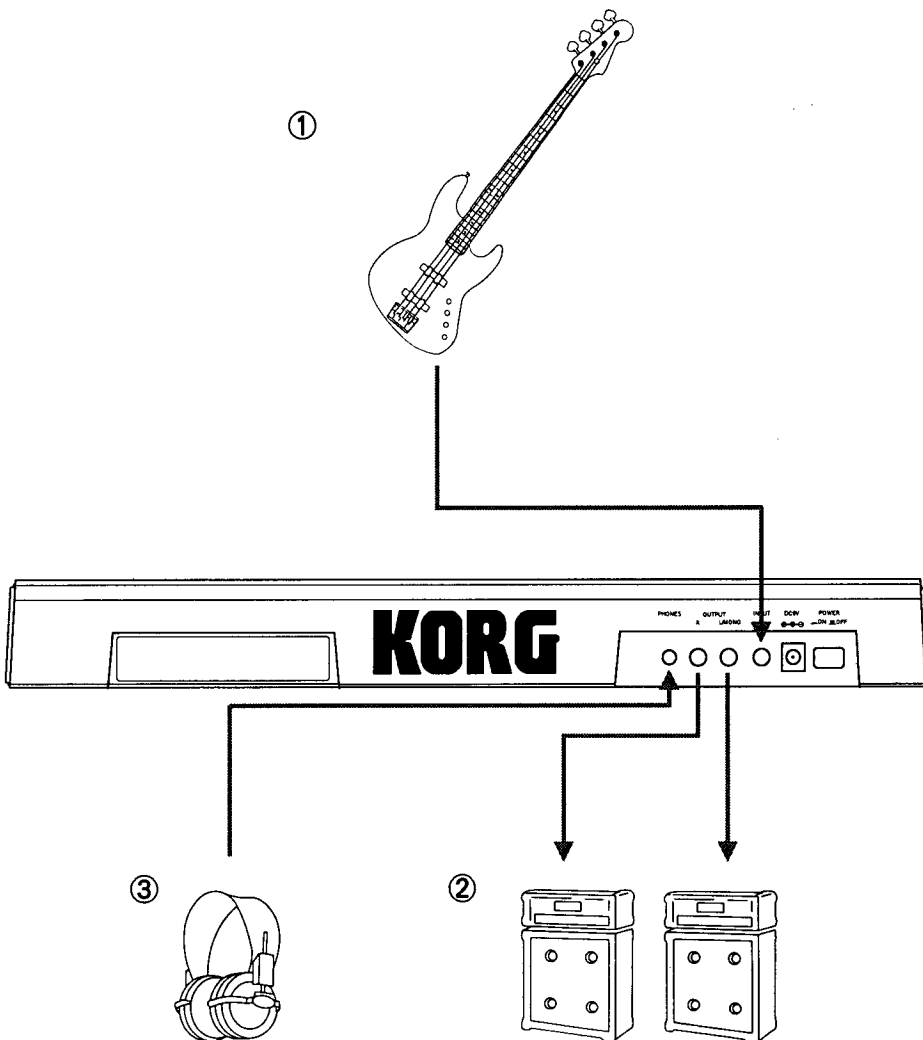

PLAYING PRESET PROGRAMS

[PROGRAM MODE]

About Preset Programs

The A5 BASS has a total of 30 effect programs stored in 6 banks. Each bank holds 5 effect programs. Banks 2 – 6 are factory presets with a total of 25 preset programs. Bank 1 is the user area for storing edited effect programs (see page 8 for details).

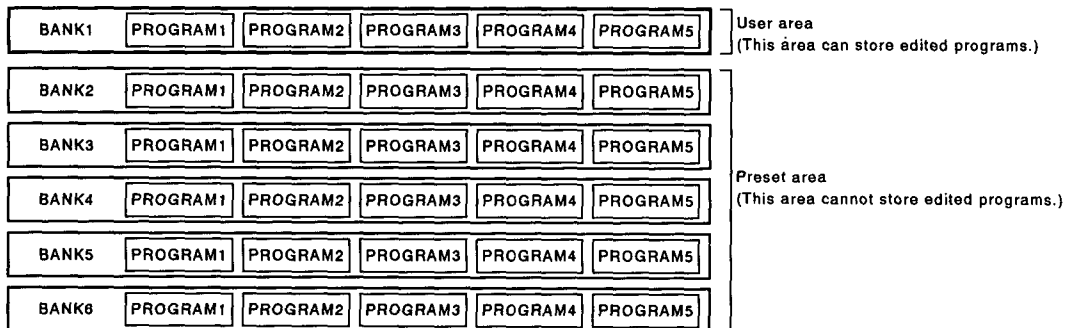

1. When the power is first turned on, the A5 BASS automatically enters into the Program mode. To switch to the Program mode from the Manual Edit mode, simply press the Mode Select Switch.

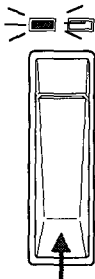

Press the switch until the PROG LED lights red.

2. Set the input level while playing the bass. Carefully raise the input level until the Peak Indicator occasionally, but not constantly, lights up.

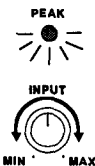

Adjust the input level such that the Peak Indicator occasionally lights up.

3. Switch the Bank/Effect Selector to the bank that contains a program you wish to play. (For parameters within each program, refer to the attached "Effect Parameter List".)

Bank 2 is selected in the figure below, for example.

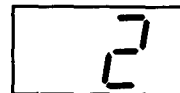
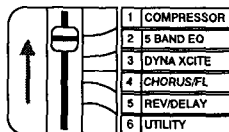

The currently selected bank number is shown in the Bank/Value Display.

4. Press any of the EFCT/PROG switches (1 – 5) to select the effect program you wish to play. For example, program 1 containing "Slap 1" is selected in the figure below.

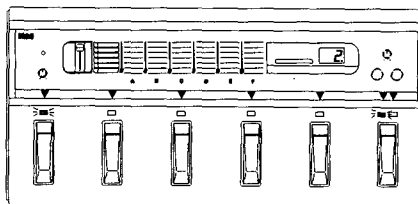

5. Play the bass to hear the effect sound with "Slap 1". To hear the unprocessed sound without effects, press the Bypass key. Re - pressing the Bypass key returns the effect sound. (The Mode LED's blink while in Bypass mode.)

6. Repeat the above procedures (3 thru 5) for selecting programs in other banks. To continue selecting programs in the same bank, simply press the EFCT/PROG switches.

NOTE : Shifting to a different bank does not select programs in that bank immediately. To select programs in a new bank, you must press one of the 5 EFCT/PROG switches after entering the new bank.

OPERATING INDIVIDUAL EFFECTS

[MANUAL/EDIT MODE]

The A5 BASS's effect system is constructed of five basic effects that are connected in a row, as in the diagram below. Each individual effect can be edited and combined with other effects to create an effect program. Each of the five effects in a program can be independently turned on and off.



1. Press the Mode Select Switch to enter the Manual/Edit mode. The mode LED above the Mode Select Switch lights up to MANUAL/EDIT, and the Bank/Value Display changes to indicate that the machine is on Edit stand – by.

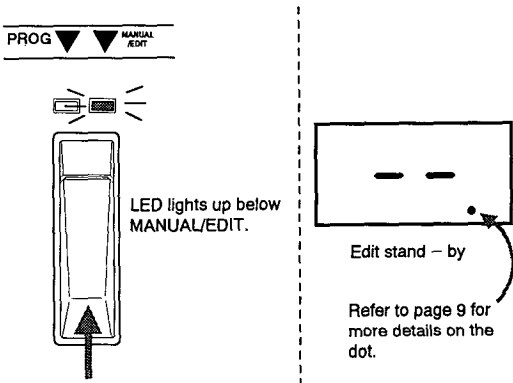

In the Manual/Edit mode, the EFCT/PROG switches (along with the EFCT/PROG LED's) control ON/OFF of each of the five effects. When entering the Manual/Edit mode, the EFCT/PROG LED's light up to display the effects which are currently turned on. For example, the figure below shows that the Manual/Edit mode is selected after selecting "Slap 1" in the Program mode.

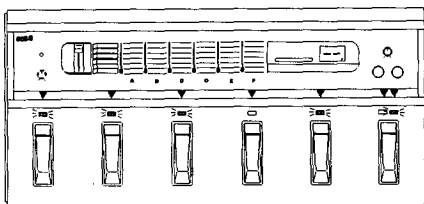

"Slap 1" consists of three effects: COMPRESSOR, 5 BAND EQ, DYNA XCITE, and REV/DELAY.

2. Press the EFCT/PROG switches to toggle the effects on and off. For example, pressing the EFCT/PROG switch immediately under (1) COMPRESSOR turns on the Compressor effect.

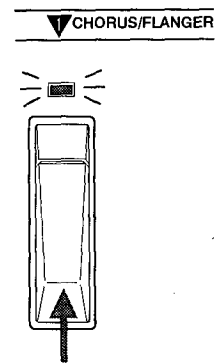

3. Press the EFCT/PROG switches once again to turn off the effect. Try different effect combinations to hear sound variations.

4. To select and hear individual effects in another program, you must return to the Program mode, once. Press the Mode switch to switch back to the Program mode. The Mode LED's, the EFCT/PROG LED's and the Bank/Value Display return to their Program mode indication. (Now, select a new program and press the Mode switch again to return to the Manual/Edit mode.)

Indicates the bank number when switching to the Program mode.

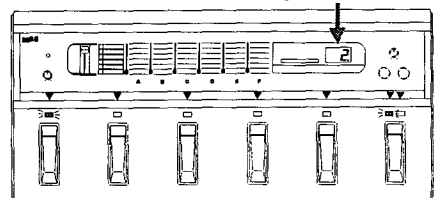

CREATING ORIGINAL PROGRAMS

[Manual/Edit Mode]

About "Parameters" and "Editing"

Changing the settings of individual effects such as the balance between direct sound and effect output is called "editing". "Parameters" are the specific settings inside each effect with values that are changeable for "editing".

Editing of parameters can be done in two ways:

- 1) Find a program that sounds closest to what you want, and create your own by editing that program.
- 2) Pick any program in the user area, and start from scratch.

While you are new to this unit, it is probably easier and faster to edit using method (1).

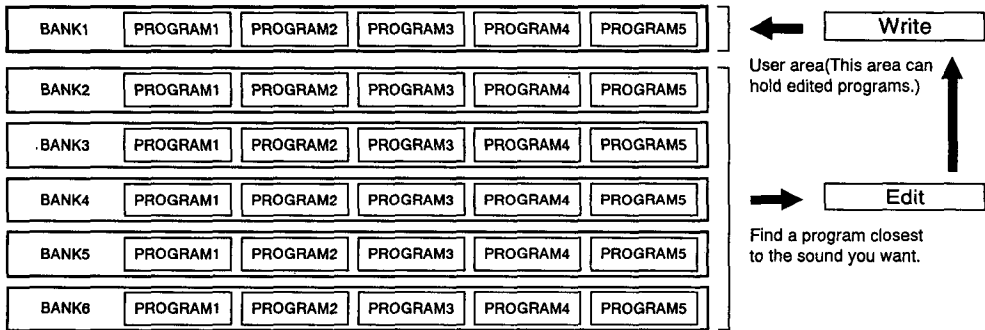

1. Enter the Program mode and find a program that sounds closest to what you want. The figure below shows selecting program 1 in Bank 2, for example. (See page 4.)

2. Enter the Edit mode by pressing the Mode Select Switch. The Mode LED's, the Value Display and the EFCT/PROG LED's will change to indicate the Edit mode.

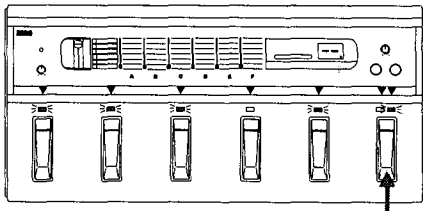

The parameters in the program are set as below, for example.

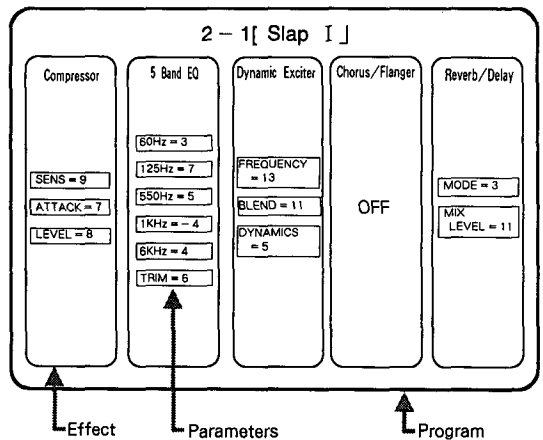

3. Slide the Bank/Effect selector to the effect you wish to edit.
The figure below shows selecting the "DYNA XCITE" (Dynamic Exciter), for example.

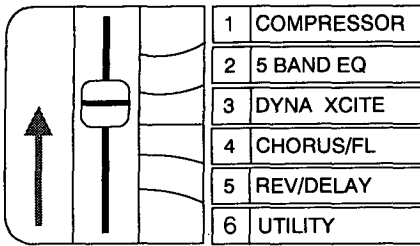

4. Find the parameter you wish to edit from the parameter names on the front panel. Moving the Slider to the left of the parameter (A – E) directly below it. To change the "FREQ" parameter of "DYNA XCITE" for example, read to the right from "DYNA XCITE" to find "FREQ", then turn the Parameter Editor "A" to set the desired sound.

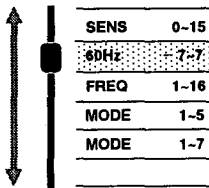

A

5. Turning the Parameter Editor changes the parameter values on the Value Display. (A dot next to a parameter value number indicates the current programmed value.)

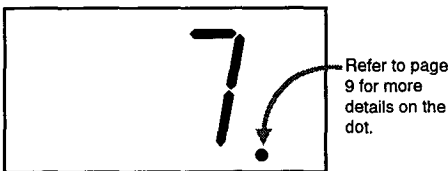

6. Repeat the same procedures for changing other parameters.
(Each individual parameters are explained on pages 10 – 12. See the attached "Effect Parameter List" for the parameter values in each preset program.)

NOTE : It is possible to edit the parameters of an effect which is turned off. Make sure that the Bank/Effect selector is in the position of the effect you wish to edit.

★ To edit other programs, switch back to the Program mode and start the procedures again. If you wish to save the edited program, execute the "Program Write" operation. (See page 8 for details.)

NOTE 1 : A currently edited program will return unaltered to its original program settings if you select another program without writing it to the memory. Original programs are safe from being erased despite any number of edits, as long as the write operation is not performed.

NOTE 2 : When entering the Program mode from the Edit mode, the position of the Bank/Effect selector may differ from the bank number displayed in the Bank/Value display. This is because the Bank/Effect selector is in the same position as the last effect edited in the Edit mode. When selecting a program in a different bank, make sure you select a new bank with the Bank/Effect selector, then select programs with the EFCT/PROG switches. (The current bank being played in the PROG Mode is shown in the Bank/Value display, with a dot to the right. If a new bank is selected, with the Bank/Effect selector, the current bank does not actually switch until a program has been selected. At that time, the new bank is entered and the dot is shown in the display.)

UTILITY

The Utility mode handles parameters relating to each program as a whole. This mode allows you to control the NR LEVEL (Noise Reduction Threshold Level) and the MASTER (Master Volume) of each program. (See page 12 for detailed explanation of each parameter.) Control procedures are the same as the editing procedures in the Edit mode.

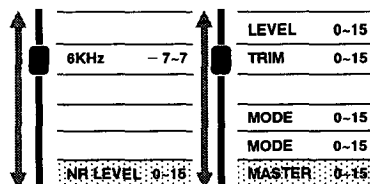
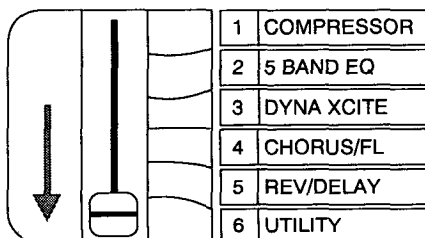

E

F

SAVING EFFECTS [PROGRAM WRITE]

When you wish to keep the programs you have edited, use the Program Write function to save them into the user area. In the A5 BASS, Bank 1 is the user area which stores up to 5 edited effect programs. Unless you use this function to save the data, the programs you have edited will be erased as soon as you select another program.

NOTE : Saving a program into a particular program number in Bank 1 will erase the current program data in that number. (Upon leaving the KORG factory, five programs were selected from Bank 2 -- 6 and copied to Bank 1.)

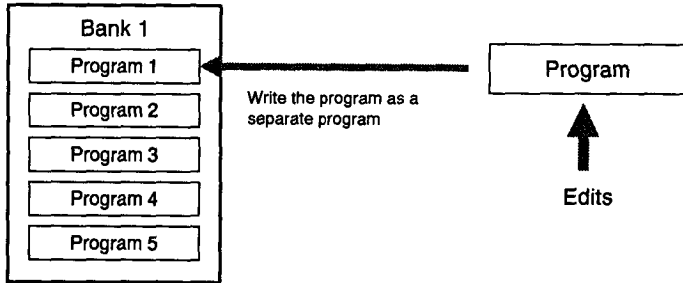

1. When editing is completed in the Edit mode, press the Write key to save the currently edited program. For example, an edited version of "Slap 1" (Program number 1 in Bank 2) is saved as a separate program.

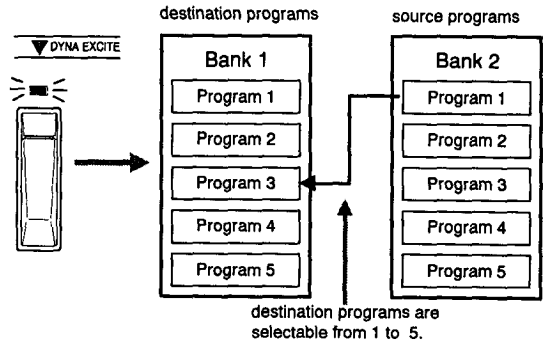

3. Press the Write key, once again. When writing operation is finished, both Mode LED's light up for about a second.

Upon pressing the Write key, the Bank/Value display flashes "1" indicating that the currently edited program is ready to be stored to Bank 1 (the user area).

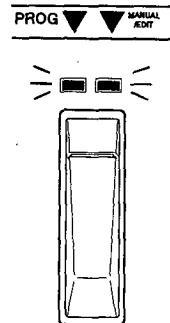
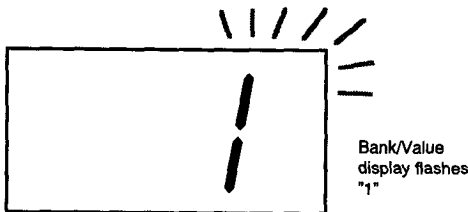

Both Mode LED's light up for about a second to indicate that the writing operation is completed.

2. Press one of five EFCT/PROG switches (1 - 5) to select a particular program number in Bank 1 to which you wish to store the edited program. In the example next, the edited program is saved to the program 3 in Bank 1.

★To cancel the write operation, press the Mode select switch in stead of pressing the Write key.

The Write function can be accessed directly from the Program mode, also.

OTHER USEFUL FUNCTIONS

1. Comparison with Preset Data

When you wish to compare an edited program with preset programs or programs stored in the user area, the dotted LED in the Bank/Value can be very useful. The dotted LED appears in each of the following modes.

A) In the Program mode

Selecting a bank alone does not select a program in that bank. After selecting the desired bank, you must use the EFF/PROG switches 1 – 5 to select the program. The dotted LED appears only if the bank and the program are both selected. In other words, the dotted LED does not appear if only the bank is selected but a program in the bank is not yet selected.



B) In the Manual mode

When each of the effects are turned On/Off, the dotted LED appears at the lower right corner of the display (under the edit-stand-by indication) if the On/Off effect setting is the same as that of the preset program. When the user area effects are turned On/Off, the dotted LED appears if the On/Off setting is the same as that of the program stored in the user area.

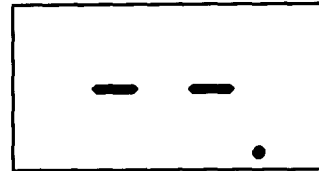

C) In the Edit mode

When each of the parameters are edited within a preset program, the dotted LED appears at the lower right corner of the display (under the parameter value) if the parameter value is the same as that of the preset program. When editing a program in the user area, the dotted LED appears if the parameters are the same as that of the program stored in the user area.

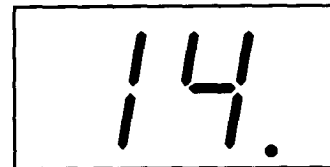

EFFECT PARAMETER LIST

1. COMPRESSOR [COMPRESSOR]

◆ This is a limiter effect which suppresses the high level attack transients of an input signal sound by compressing that signal. This effect helps emphasize the attack sound or lengthen the sustain sound by raising the level as a sound decays.

◆ Parameters

A	SENS (SENS)	[0-15]	Degree of the compressor effect. The larger this value, the greater the sustain or the attack is emphasized.
B	ATTACK (ATTACK)	[0-7]	Speed of the attack. The higher this value, the faster the attack.
F	LEVEL (LEVEL)	[0-15]	Output level of the effect sound.

2. 5 BAND EQ [5 BAND EQ]

◆ This is a graphic type equalizer with 5 selected frequency bands that serve the best for playing the bass.

◆ Parameters

A	60Hz	[- 7-7]	Gain centered at 60Hz.
B	100Hz	[- 7-7]	Gain centered at 100Hz.
C	550Hz	[- 7-7]	Gain centered at 550Hz.
D	1kHz	[- 7-7]	Gain centered at 1kHz.
E	6kHz	[- 7-7]	Gain centered at 6kHz.
F	TRIM	[0-15]	Gain for equalizer.

☆ APPLICATION NOTE:

"Lower the TRIM to keep output sound from being distorted."

Depending on the setting of this 5 BAND EQ, the output may be distorted (or clipped) even when the Peak LED is not lit. In such cases, turn down the TRIM parameter until the clipping stops.

3. DYNAMIC EXCITER [DYNA XCITE]

◆ This effect gives clarity, definition and presence to the sound by emphasizing specific range of harmonics, and the depth of the effect can be controlled by picking dynamics. It is especially effective for "chopper" playing.

◆ Parameters

A	FREQ (FREQUENCY)	[1-16]	Center frequency for exciter effect.
B	BLEND (BLEND)	[- 2-12]	Depth of the exciter effect. The larger this value, the deeper the exciter effect. Negative values cut off the harmonics.
C	DYNAMICS (DYNAMICS)	[0-15]	Effective range of the depth controlled by picking dynamics. "0" value plays the effect with the depth set in BLEND, regardless of actual picking dynamics. When set to larger values, softer picking plays the depth set in BLEND, and harder picking plays even deeper.

4. CHORUS/FLANGER [CHORUS/FL]

◆ This effect creates a swirling, warm sound by constantly modulating the pitch of the input. This effect has five modes; 2 types of chorus effects, 2 types of flanger effects and a slapback delay effect.

◆ Parameters

A	MODE (MODE)	[1-5]	1: Flanger 1 (Modulates high harmonics. Delay time = 1.8mSEC) 2: Flanger 2 (Modulates low harmonics. Delay time = 4.0mSEC) 3: Chorus 1 (Delay time = 24mSEC) 4: Chorus 2 (Delay time = 32mSEC) 5: Slapback (Delay time = 75mSEC)
B	SPEED (SPEED)	[0-15]	Speed of modulation.
C	DEPTH (DEPTH)	[0-15]	Depth of modulation. The larger this value, the higher the modulation.
D	F.BACK (FEED BACK)	[0-15]	Amount of feedback. Larger values create deeper modulation in mode 1 and mode 2. A zero value creates clearer chorus sound in mode 3 and mode 4. A setting of 1 or 2, with the slapback delay, creates a typical "Rock - a - billy" type bass sound.
F	MIX (MIX LEVEL)	[0-15]	Balance between effect sound and direct output. At value 15, the balance is 50/50. At value 0, direct output only.

5. REVERB/DELAY [REV/DELAY]

◆ This effect has a total of 7 effects including various reverb, delay and echoverb effects. The reverb effects provide spacial depth to a sound by simulating the ambience and reverberation characteristics of natural locations such as a concert hall or a room. The delay effect provides repeated echo reflections to a sound. The echoverb effect is a combination of reverb and delay.

◆ Parameters

A	MODE (MODE)	[1-7]	1: HALL REVERB 2: ENSEMBLE HALL REVERB 3: ROOM REVERB 4: PLATE REVERB 5: LIVE STAGE REVERB 6: ECHOVERB 7: DELAY
B	TIME (DELAY TIME)	[0-3] (MODE6) [0-4] (MODE7)	Delay time between direct sound and effect output. (Set in 100 – mSEC steps.) Delay time cannot be set in Mode 1~ Mode 5.
C	FINE (DELAY TIME FINE)	[0-9]	Delay time between direct sound and effect output. (Set in 10 – mSEC steps.) Delay time cannot be set in Mode 1~ Mode 5.
D	F.BACK (FEED BACK)	[0-15]	Amount of feedback. The larger this value, the more times the delay sound is repeated. This value cannot be set in Mode 1~ Mode 5.
F	MIX (MIX LEVEL)	[0-15]	Balance between effect sound and direct output. At value 15, the balance is 50/50. At value 0, direct output only.

6. UTILITY [UTILITY]

◆ This controls the master volume of each effect program and the threshold level for the noise reduction (NR) system.

◆ Parameters

E	NR LEVEL (NOISE REDUCTION THRESHOLD LEVEL)	[0-15]	The larger this value, the higher the amount of noise reduction. Adjust this value until no noise can be heard in the sound when not playing the guitar.
F	MASTER (MASTER VOLUME)	[0-15]	The larger this value, the higher the output level of the program.

ERROR MESSAGES

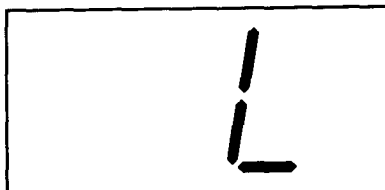

L (Battery Low)

When the above message appears immediately after turning on the A5 BASS (or when "F" appears in the display upon every start-up), the battery for internal memory backup needs to be replaced.

Contact the KORG distributor nearest you or your local KORG dealer or service center and have a qualified technician replace it.

TROUBLESHOOTING

If a problem occurs during normal operation of the A5 BASS, follow the suggestions below and check the A5 BASS to spot and remedy the trouble. If the A5 BASS still does not function properly, consult the KORG distributor nearest you or your local KORG dealer.

Trouble	Countermeasure
No sound	<ol style="list-style-type: none"> 1. Check if the Input volume or the Output volume is set to 0. Adjust the level until the input signal reaches the peak indicator, or raise the output volume until sound can be monitored with headphones. 2. It is possible that the level parameter in one of the effects may be set to 0. In such a case, sound can be heard only when pressing the BYPASS key. Enter the Edit mode and adjust the appropriate Level parameters. 3. Check if the master volume in the Utility mode is set to 0. If so, reset it to a suitable level.
No effect. No change in effect when editing.	<ol style="list-style-type: none"> 1. Check the Mode LED's to ensure that the Edit mode is selected. 2. Check the Bank/Effect selector to ensure that the desired effect is properly selected. 3. Check if Bypass has been turned on. When the Mode LED's are blinking, the A5 BASS is in Bypass condition. Press the Bypass key to turn it off. 4. Check if the MIX LEVEL parameter in one of the effects is set to 0. If so, reset it to a suitable level. 5. Check if any effects have been set to OFF. Make sure the EFCT/PROG LED's are lit for the effects you wish to edit.
Write operation is attempted but not executed.	<ol style="list-style-type: none"> 1. Check if you have attempted to write to the User area. A program can be stored only to the five programs 1 - 5 in Bank 1. 2. After the write operation is executed, the A5 BASS continues to display the source bank and program number, not the destination bank and program number. If you wish to hear the destination program, use the Bank/Effect selector to select Bank 1 and select the program.

SPECIFICATIONS AND OPTIONS

- Internal Effects :
COMPRESSOR, 5 BAND EQ, DYNAMIC EXCITER, CHORUS/FLANGER, REVERB/DELAY
- Program :
Preset = 25, User programmable = 5
- Front Panel :
Volume : INPUT VOLUME, PARAMETER EDITORS, OUTPUT VOLUME
KEY SW : BANK/EFFECT SELECTOR, WRITE KEY, BYPASS KEY,
EFCT/PROG SWITCHES, MODE SELECT SWITCH
Display : BANK/VALUE Display : 8 segment LED x 2
Dot type LEDs : EFCT/PROG LEDs, MODE LEDs, Peak Indicator
- Rear Panel:
Power Switches
DC9V Jack
INPUT Terminal
OUTPUT Terminal x 2 (R, L/MONO)
PHONES Jack
- Sampling Frequency : 44.1kHz
- Dynamic Range : 88 dB (IHF – A)
- Power Consumption : 250 mA
- Input Impedance : 1M Ω
- Maximum Input Level : +8dBm
- Output Impedance : 5k Ω or less
- Maximum Output Level : +8dBm
- Dimensions : 430(W) \times 205(D) \times 60(H) mm
- Weight : 1.5kg

★ Specifications, operations, and appearance are subject to change without notice.

N O T I C E

KORG products are manufactured under strict specifications and voltages required by each country. These products are warranted by the KORG distributor only in each country. Any KORG product sold without a warranty card or not carrying a serial number disqualifies the product from the manufacturer's warranty and liability. This requirement is for your own protection and safety.

KORG

KORG INC.

15 - 12, Shimotakaido 1 - chome, Suginami - ku, Tokyo, Japan.

©KORG INC. 1990

0211 EAH PRINTED IN JAPAN

Ⓔ