

Korg Concert Piano

OWNER'S MANUAL C-56M

KORG

IMPORTANT SAFETY INSTRUCTIONS

WARNING : When using electric products, basic precautions should always be followed, including the following.

1. Read all the instructions before using the product.
2. Do not use this product near water — for example, near a bathtub, washbowl, kitchen sink, in a wet basement, or near a swimming pool, or the like.
3. This product should be used only with a cart or stand that is recommended by the manufacturer.
4. This product, either alone or in combination with an amplifier and headphones or speakers, may be capable of producing sound levels that could cause permanent hearing loss. Do not operate for a long period of time at high volume level or at a level that is uncomfortable. If you experience any hearing loss or ringing in the ears, you should consult an audiologist.
5. The product should be located so that its location or position does not interfere with its proper ventilation.
6. The product should be located away from heat sources such as radiators, heat registers, or other products that produce heat.
7. The product should be connected to a power supply only of the type described in the operating instructions or as marked on the product.
8. The power-supply cord of the product should be unplugged from the outlet when left unused for a long period of time.
9. Care should be taken so that objects do not fall and liquids are not spilled into the enclosure through openings.
10. The product should be serviced by qualified service personnel when:
 - A. The power-supply cord or the plug has been damaged; or
 - B. Objects have fallen, or liquid has been spilled into the product; or
 - C. The product has been exposed to rain; or
 - D. The product does not appear to operate normally or exhibits a marked change in performance; or
 - E. The product has been dropped, or the enclosure damaged.
11. Do not attempt to service the product beyond that described in the user-maintenance instructions. All other servicing should be referred to qualified service personnel.

SAVE THESE INSTRUCTIONS

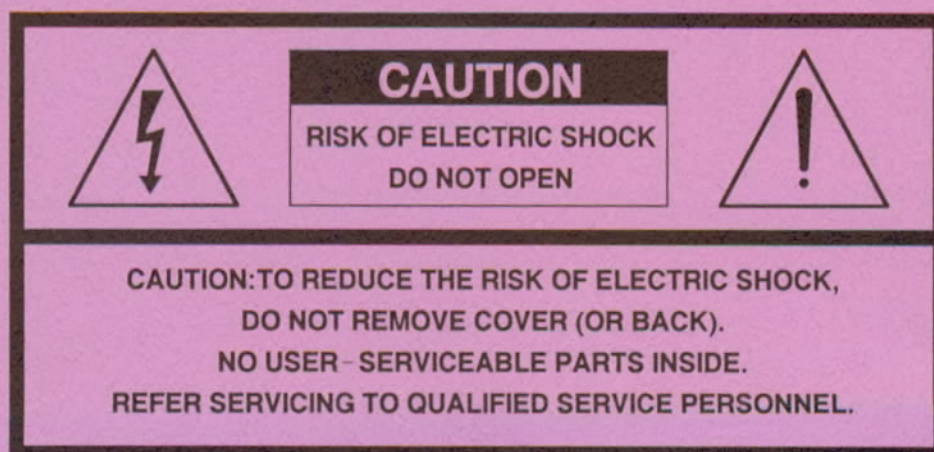



The lightning flash with arrowhead symbol, within an equilateral triangle, is intended to alert the user to the presence of uninsulated "dangerous voltage" within the product's enclosure that may be of sufficient magnitude to constitute a risk of electric shock to persons.



The exclamation point within an equilateral triangle is intended to alert the user to the presence of important operating and maintenance (servicing) instructions in the literature accompanying the product.

THE FCC REGULATION WARNING

This equipment generates and uses radio frequency energy and if not installed and used properly, that is, in strict accordance with the manufacturer's instructions, may cause interference to radio and television reception. It has been type tested and found to comply with the limits for a class B computing device in accordance with the specifications in Subpart J of Part 15 of FCC Rules, which are designed to provide reasonable protection against such interference in a residential installation. However, there is no guarantee that interference will not occur in a particular installation. If this equipment does cause interference to radio or television reception, which can be determined by turning the equipment off and on, the user is encouraged to try to correct the interference by one or more of the following measures:

- Reorient the receiving antenna.
- Relocate the equipment with respect to the receiver.
- Move the equipment into a different outlet so that equipment and receiver are on different branch circuits.
- Plug the equipment into a different outlet so that equipment and receiver are on different branch circuits.

If necessary, the user should consult the dealer or an experienced radio/television technician for additional suggestions. The user may find the following booklet prepared by the Federal Communications Commission helpful. "How to Identify and Resolve Radio-TV Interference Problems". This booklet is available from the US Government Printing Office, Washington D.C. 20402, stock No. 004-000-000345-4.

CANADA

THIS DIGITAL APPARATUS DOES NOT EXCEED THE "CLASS B" LIMITS FOR RADIO NOISE EMISSIONS FROM DIGITAL APPARATUS SET OUT IN THE RADIO INTERFERENCE REGULATION OF THE CANADIAN DEPARTMENT OF COMMUNICATIONS.

LE PRESENT APPAREIL NUMERIQUE N'EMET PAS DE BRUITS RADIO-ELECTRIQUES DEPASSANT LES LIMITES APPLICABLES AUX APPAREILS NUMERIQUES DE LA "CLASS B" PRESCRITES DANS LE REGLEMENT SUR LE BROUILLAGE RADIOELECTRIQUE EDICTE PAR LE MINISTERE DES COMMUNICATIONS DU CANADA.

CAUTION: TO PREVENT ELECTRIC SHOCK, MATCH WIDE BLADE OF PLUG TO WIDE SLOT, FULLY INSERT.

ATTENTION: POUR ÉVITER LES CHOCS ÉLECTRIQUES, INTRODUIRE LA LAME LA PLUS LARGE DE LA FICHE DANS LA BORNE CORRESPONDANTE DE LA PRISE ET POUSSER JUSQU' AU FOND.

Thank you for purchasing the Korg Concert Piano C- 56M. To ensure long, trouble-free operation, please read this manual carefully.

Before You Begin

■ Location

To prevent damage to the C- 56M's electronics, do not use or store it for extended periods where it may be exposed to:

- direct sunlight
- extreme temperature or humidity
- sand or dust
- excessive vibration

■ Power Supply

- Only connect the C- 56M to electrical outlets matching the specifications on the name plate at the rear of the unit.

Note : If necessary, add the appropriate step-up or step-down transformer. Connecting to the wrong polarity or voltage can irreparably damage the C- 56M.

- To help prevent noise and poor sound quality, avoid connecting the C- 56M to the same electrical circuit as motors or large appliances.
- For the same reasons, never overload the electrical circuit with too many extension cords.
- Always start with the volume at a low level and gradually increase it — especially when the C- 56M is connected to external equipment.

■ Interference

To minimize the risk of radio-frequency interference:

- Keep the C- 56M away from fluorescent light fixtures and other sources of radio-frequency noise that may disrupt operation of the C- 56M's main microprocessor.
- Never use the C- 56M in the immediate vicinity of a radio, television set, or similar equipment, as the equipment may pick up radio-frequency noise from the microprocessor.
- If operation becomes erratic or unpredictable or the C- 56M fails to respond, reset the micro-processor by turning off the C- 56M, waiting a few seconds and then turning it on again.

■ Rear Connections

- Only use jacks and connectors matching the corresponding connectors available at the rear of the C- 56M.

■ Handling

- Never apply excessive force to keys, switches, terminals and other components.
- Avoid dropping the C- 56M.

■ Clearance

- Do not place the C- 56M directly against the wall. Always leave a little space behind it to allow the sound to project from the back, bounce off the walls, ceiling and floor, thus creating a richer sound.

■ Cleaning

- Wipe the exterior of the C- 56M with a clean, dry cloth to remove dust and dirt.
- Never use harsh cleansers, organic solvents, or flammable polishes.

■ Foreign Objects

- Do not place vases or beverage containers on the C- 56M. Liquid spills may cause fire or electrical shock, as well as cause permanent damage to the C- 56M.
- Care should be taken so that metal objects such as pins and coins do not fall into the enclosure through openings between keys.

If any of the above has occurred, turn off the power, unplug the power cord from the outlet and contact your dealer or a KORG service center.

■ Warranty

Have your warranty card validated at the place of purchase and keep it in a safe place until the warranty period expires.

■ Manual

This manual is your guide to using the C- 56M properly and effectively. Keep it in a safe place.

■ The Backup Battery

The C- 56M contains a lithium battery that retains the effect settings for each voice and combination of voices, as well as sequence data when the power is turned off. Five years following the date of purchase, please contact your dealer or a KORG service center for replacement.

Contents

Before You Begin	1	Advanced Recorder Procedures	26
Assembling the Stand	3	Repeating Playback	26
Control Functions	5	Putting the Recorder to Work	29
Front Panel	5	Simultaneously Playing Back Both Tracks	30
Rear Panel	6	Simultaneous Recording and Playback	30
Getting Started	7	“Punching In”	
Using the Front Panel Controls	9	(Cuing a Track for Re-Recording)	31
Selecting different voices	9	“Multi-Track Recording ”	
Selecting effects	10	(by Merging Tracks)	33
Selecting Voice Modes	11	Erasing a TRACK	33
Changing Voices in Two-Voice Modes	12	Using the Built-In Metronome	34
Changing the Octaves of Voices	12	Using the MIDI Functions	36
Changing the Split Point	13	MIDI Controls	37
Adjusting the Relative Volume	13	1. Changing the MIDI Transmit Channel	38
Using the pedals	14	2. Changing the LOCAL ON/OFF Setting	38
Changing Temperaments	16	3. Sending a PROGRAM CHANGE Request	39
Touch Controls	17	4. Inhibiting CONTROL CHANGE Requests	41
Playing Demo Songs	17	5. Changing the MIDI Velocity Curve	42
Changing Pitch : TRANSPOSE and TUNE	19	Synchronizing with external MIDI devices	43
TRANSPOSE Function	19	MIDI MULTI Function	44
TUNE Function	21	Using the MIDI Data Dump Function	46
Using the Built-In Recorder	22	MIDI Implementation	48
Recorder Controls	22	MIDI/TRANSPOSE Switch	50
Basic Record/Playback Procedures	24	Trouble Shooting	51
Recording a Track	24	Specifications	51
Reading the Memory Usage Gauge	24		
Playing Back a Track	25		

Assembling the Stand

● You will require a phillips head screw driver to assemble your new Concert Piano.

- D. Piano body..... 1
- A. Pedestal 1
- B. Levelers 2
- C. Metal brackets ... 2
- E. Front screen 1
- F. Rear screen 1
- G. Front legs 2
- ① Screws..... 8
- ② Wing nuts 4

Do not remove the tape from the key cover until the assembly procedure is completed.

The piano can easily be assembled by laying it on its back, with the large Korg logo on the rear panel touching the floor. To avoid damaging the piano, cover the floor with the piano's packing material. Then gently place the piano on the packing material, making sure that the power cord is pulled out from underneath the piano.

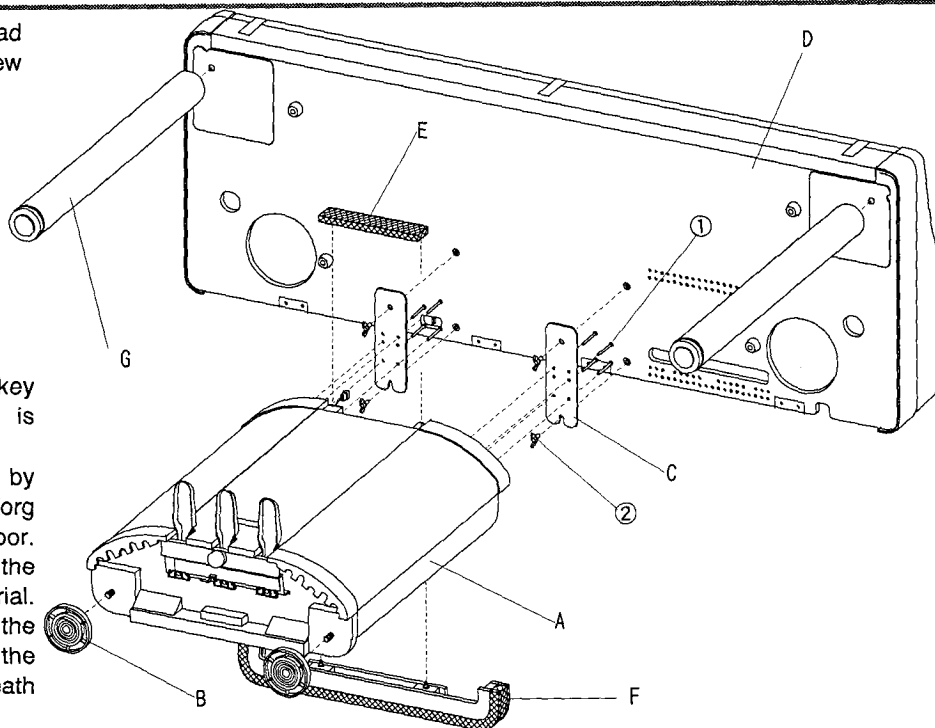

1 Screw the levelers (B) onto the threaded bolts (a1) at the bottom of the pedestal (A).

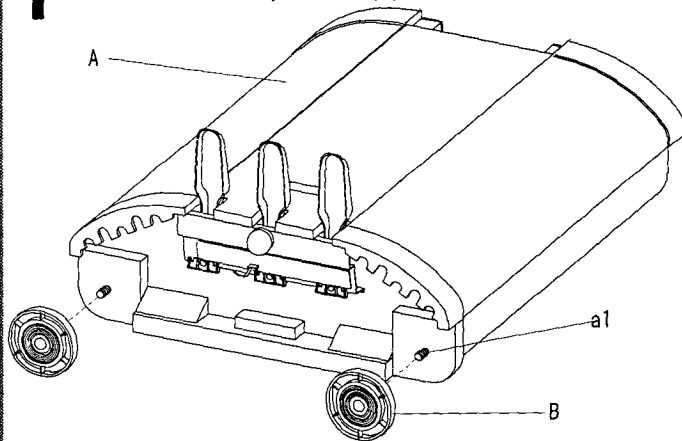

2 Use the screws ① to attach the metal brackets (C) to the top of the pedestal (A). Make sure that the metal brackets are placed onto the top of the pedestal with the recessed holes facing upward.

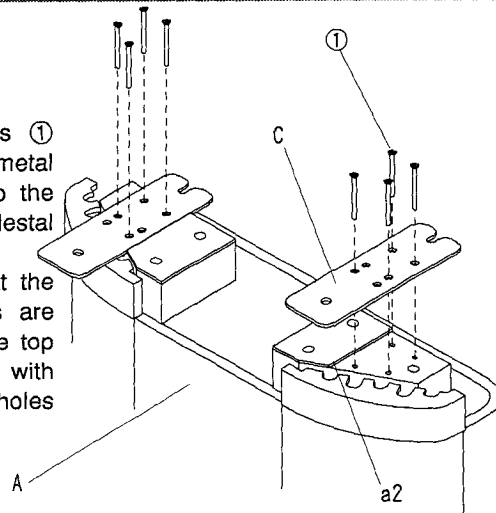

3 Screw the two wing nuts ② into the holes (d1) at the underside of the piano body. Tighten the wing nuts loosely, leaving approximately 1/4 inch between the wing nuts and the piano body.

Carefully screw the front legs (G) into the underside of the piano body at a 90 degree angle. Beware that screwing the legs at an oblique angle may damage the threaded bolts.

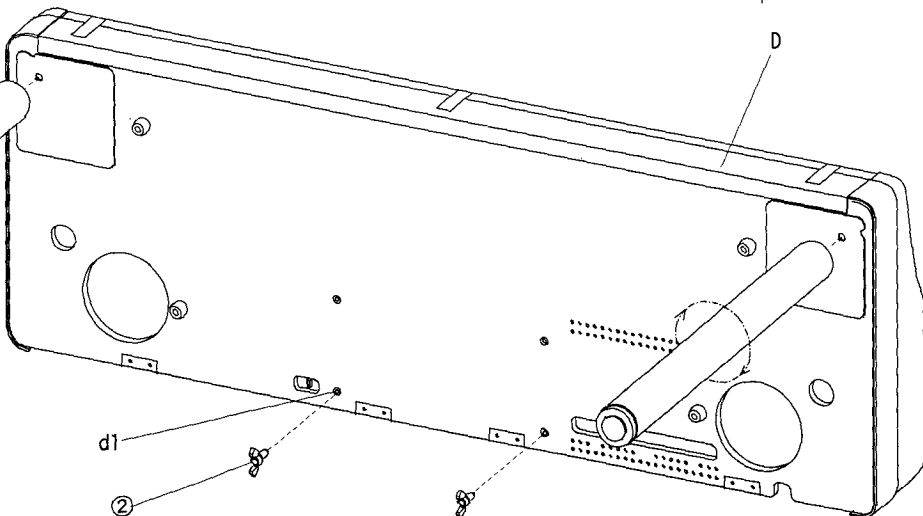

4 Attach the pedestal to the piano body (D) by sliding the notched ends of the metal brackets between the wing nuts ② and the piano body. Do not tighten the wing nuts at this time.

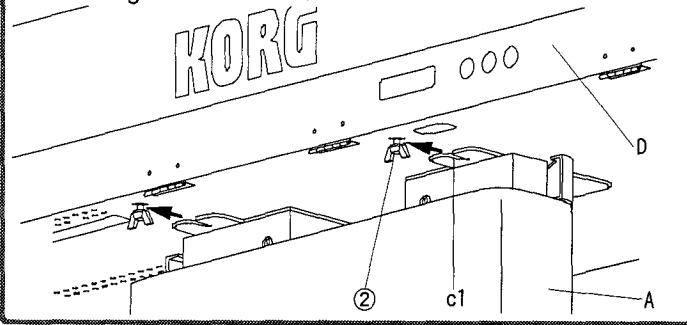

5 Insert and tighten two wing nuts ② at the front of the pedestal. Now tighten the wing nuts at the rear of the pedestal.

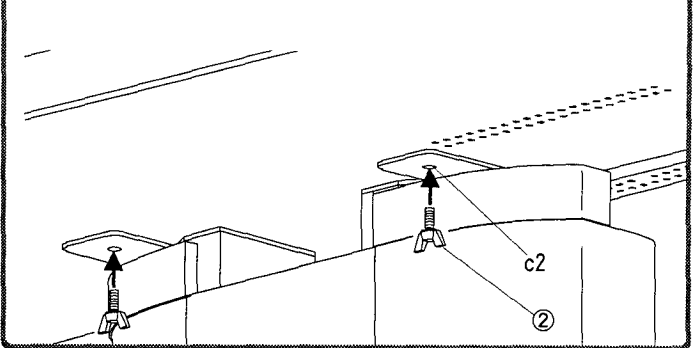

6 Insert the connector (a3) at the rear of the pedestal into the receptacle at the underside of the piano as shown above.

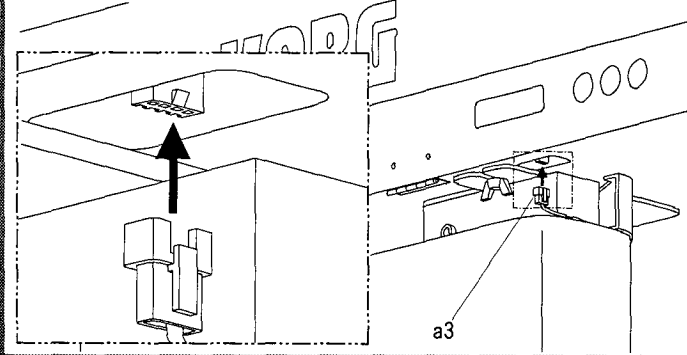

7 Affix the front screen (E).

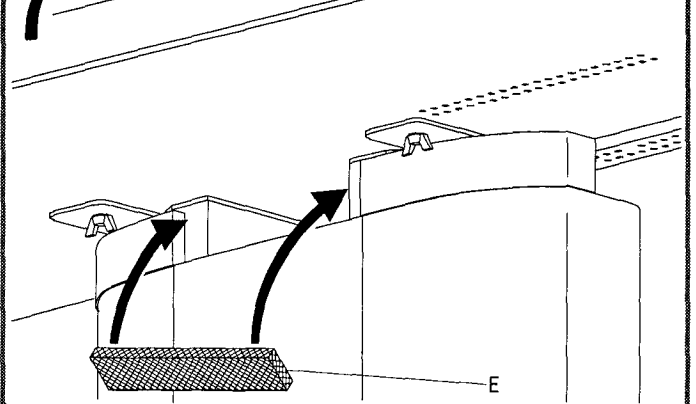

8 Affix the rear screen (F). Make sure that no part of the harness protrudes between the rear screen and the piano body.

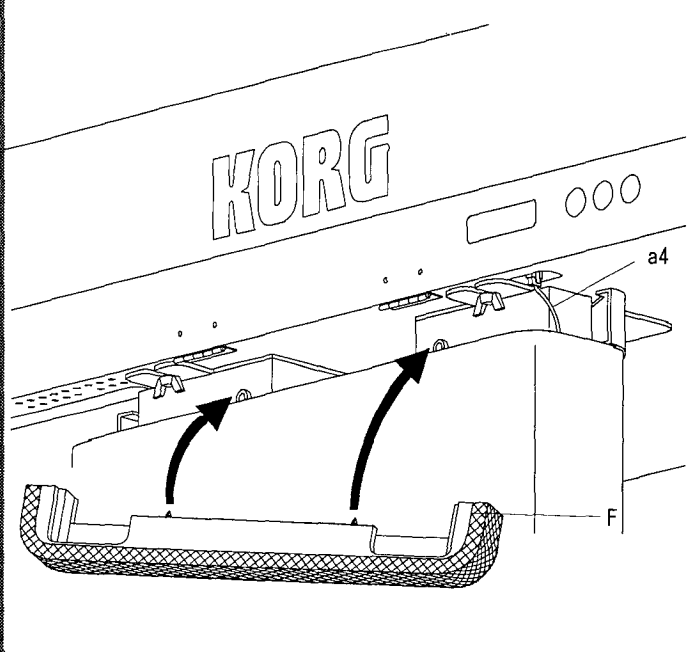

9 Adjuster each leveler (a5, B, g1) until the piano stands firmly on the floor. A wobbly piano may introduce excessive vibration to the sound. Prop up the music stand.

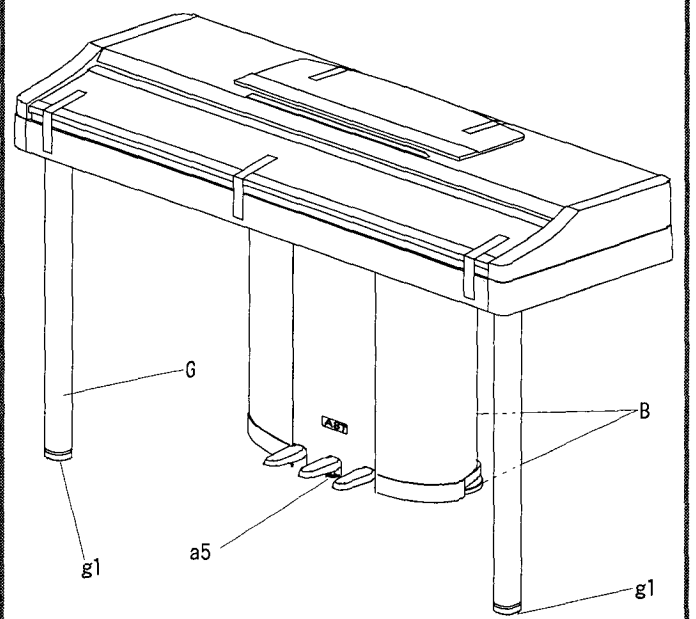

● **Keyboard Cover**

The keyboard cover folds down to cover the entire keyboard. To avoid damaging it and the keyboard:

- Always grasp the cover in the middle when lifting.
- Never force the cover in or out.

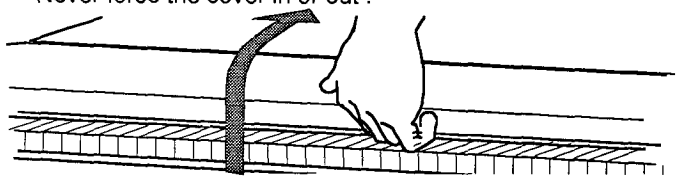

● **Music Stand**

To prop up the music stand, pull out the flaps and fit them into the base, forming a triangle.

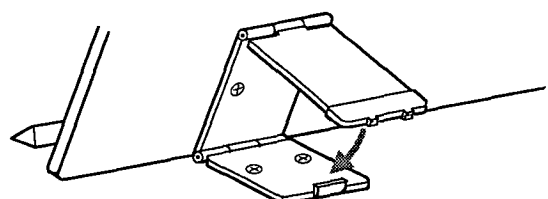

Control Functions

Front Panel

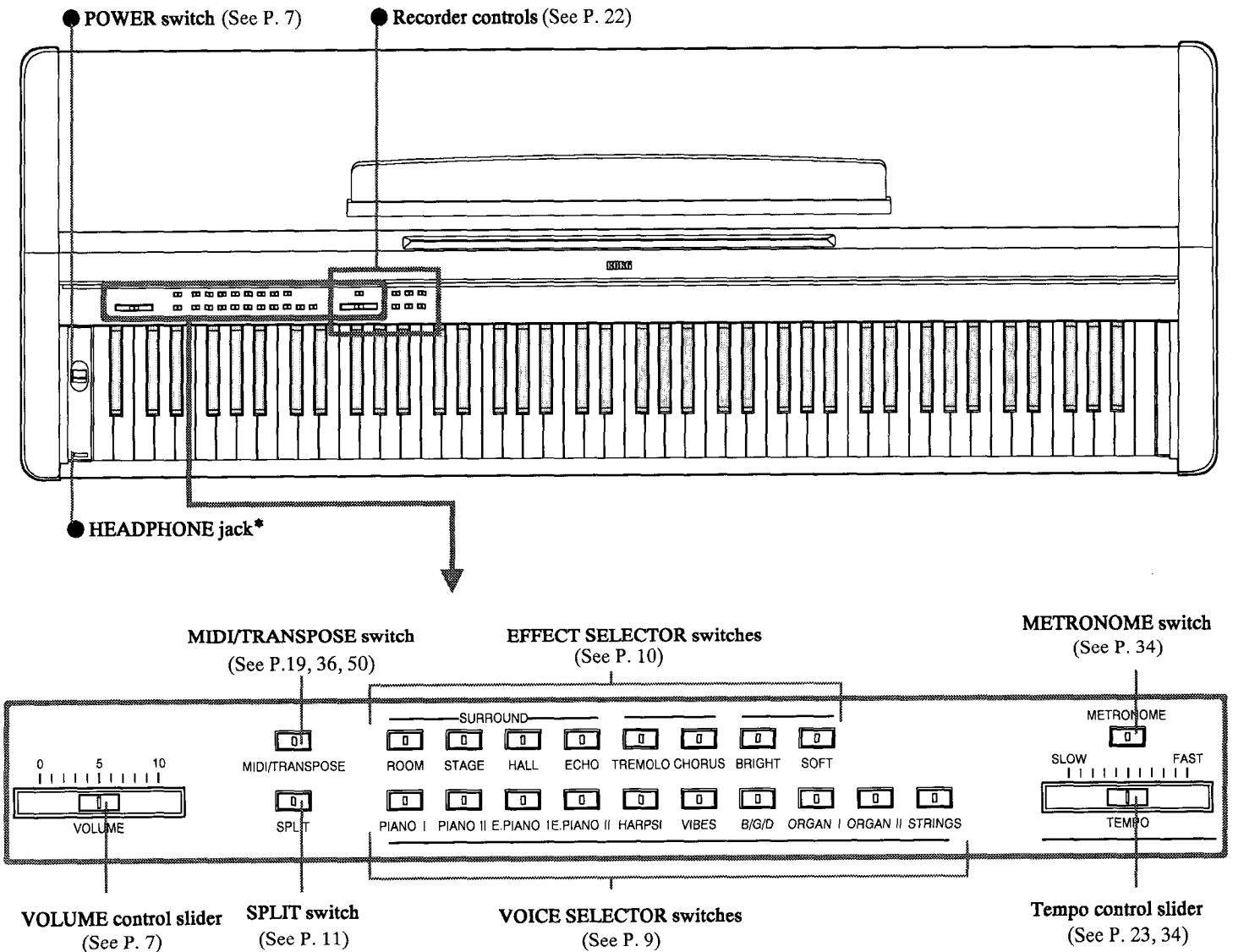

*This jack is for connection of a set of stereo headphones. It allows you to play the instrument at any volume level without disturbing others; the internal speakers are turned off when headphones are connected.

Rear Panel

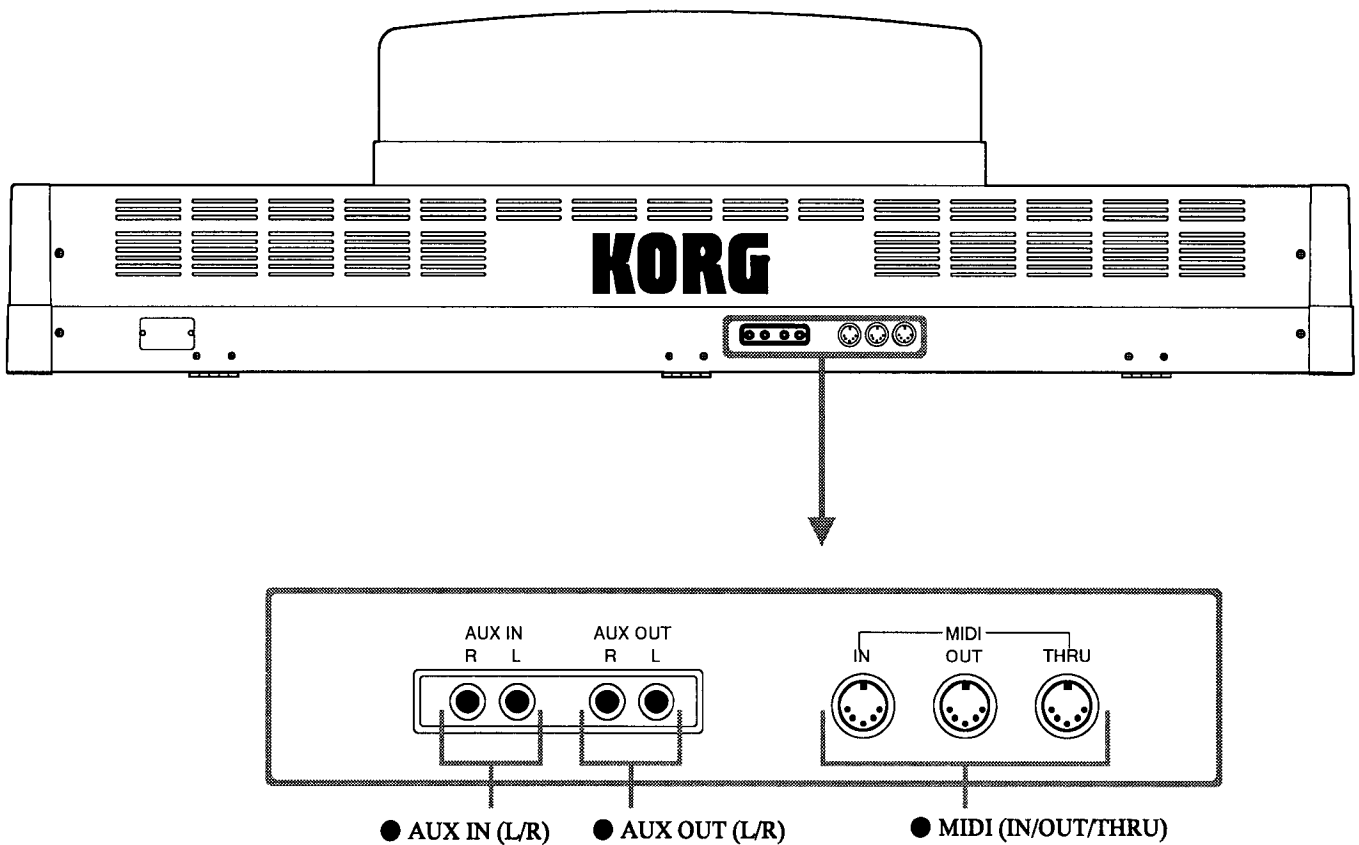

- **AUX IN (L/R):**

These RCA jacks are for connecting audio signals from synthesizers, drum machines, and other equipment to the C-56M's built-in speakers.

Note: Adjust the volume of the connected instrument from that instrument's controls.

- **AUX OUT (L/R):**

These RCA jacks are for connecting the C-56M to the AUX (or LINE) IN jacks on mixers, tape recorders, or home audio systems for routing output to a different speaker system, for example. Note: The VOLUME slider on the front panel controls the output level.

- **MIDI (IN/OUT/THRU):**

These DIN connectors accept optional MIDI cables for connecting the C-56M to synthesizers, sequencers, and other MIDI devices. In addition, the connectors are for exchanging performance and other types of data. (See p. 36)

Getting Started

1. Plug in the unit.

Plug the AC power supply cord into an appropriate power outlet (see “Before You Begin” on P. 1).

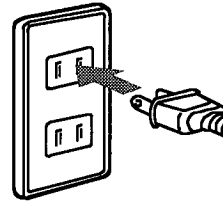

2. Press the POWER switch and wait two seconds.

Note : When the C-56M is turned on, it is set to the PIANO I voice.

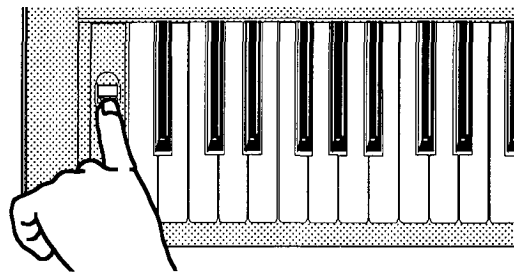

3. Adjust the volume.

Slide the volume control to the left to lower the output level, and slide it to the right to increase the output level.

Note : It is a good idea to always start with the volume at a low level and gradually increase it — especially when the C-56M is connected to external equipment.

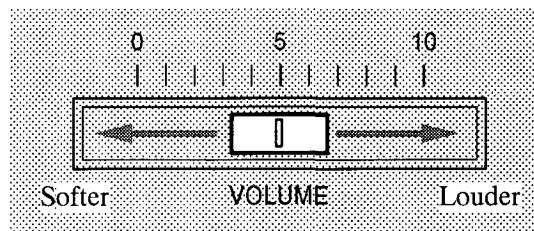

Note : This control determines the output level for the built-in speakers, headphone jack, and the AUX OUT jacks.

4. Play the AUTO DEMO Sequences!

The piano comes with pre-programmed demonstration songs. Use the following procedure to play back any desired song.

- ① Hold the MIDI/TRANPOSE switch and press the START/STOP switch.
- ② Several VOICE SELECTOR switches light up for a demo song to be selected. Press any of the lit VOICE SELECTOR switches. The selected song will be played back.

(Use the volume and tempo sliders to adjust the volume and tempo.)

VOICES	DEMO SONGS
PIANO I	Beethoven/Für Elise
PIANO II	Chopin/Nocturne Op. 9 – 2
E.PIANO I	Chopin/Prelude Op. 28 – 15
E.PIANO II	KORG demo 1
HARPSI	KORG demo 2
VIBES	KORG demo 3
B/G/D	KORG demo 4
ORGAN I	KORG demo 5
ORGAN II	KORG demo 6
STRINGS	Liszt/Consolation No. 3

To stop playing the demo song,

To stop playing the demo song while it is being played, press the START/STOP switch. The demo song is cancelled and the piano will return to its normal setting. To cancel the demo song before it is played, press the START/STOP switch twice.

- You can also playback all songs in succession (medley), or repeat a single song or all songs. (Refer to page 17)

5. Select Different Sounds

Selecting different sounds is as easy as pressing the VOICE SELECTOR switches.

Note : The LED indicator inside the selected switch lights to indicate the current voice.

Note : It is also possible to use two voices at the same time. (See # 7 below.)

(See page 9 for further information.)

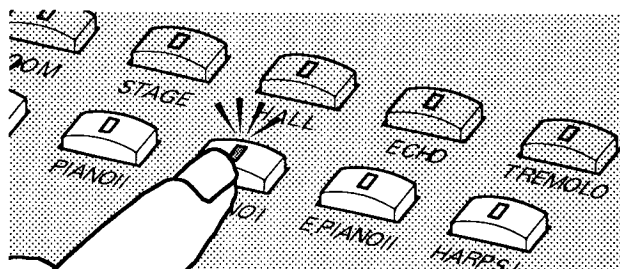

6. Adding Effects

Adding, changing, and deleting effects is as easy as pressing the EFFECT SELECTOR switches.

Note : The LED indicators inside the switches light to indicate which effects are on.

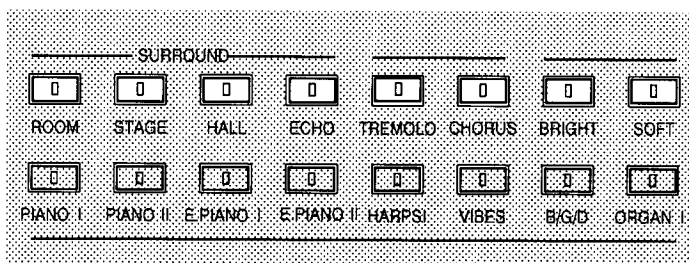

(See page 10 for further information.)

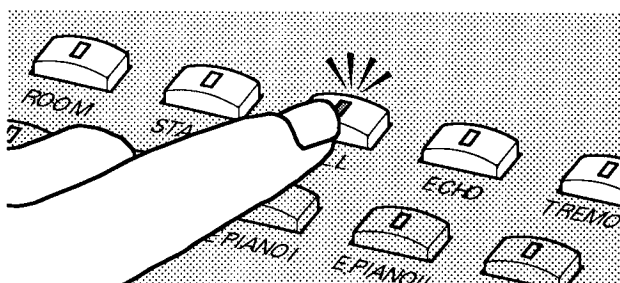

7. Play two sounds at the same time (by changing Voice Modes)

The C- 56M provides three different Voice Modes, two of which, LAYER and SPLIT, produce two different sounds at the same time.

(You have been using **SINGLE Mode** thus far, which produces one sound over the entire range of the keyboard.)

- **Press and hold one Voice Select Switch, then press a second—**

This produces the **LAYER Mode**, which combines two selectable sounds over the entire range of the keyboard.

- **Press the SPLIT Switch—**

This produces the **SPLIT Mode**, which divides the keyboard into two zones, upper and lower, each with its own selectable sound.

(See page 11 for further information.)

Now you are ready to further explore the features and operation of your C- 56M Piano.

Using the Front Panel Controls

Selecting different voices

Following are the Voices available in the C - 56M by depressing the VOICE SELECT switches:

- PIANO I : Bright acoustic grand piano.
- PIANO II : Rich acoustic grand piano.
- E.PIANO I : Synthesized electric piano.
- E.PIANO II : Electric piano.
- HARPSI : Traditional harpsichord.
- VIBES : Jazz vibraphone.
- * * B/G/D : Combination of three sounds: acoustic bass, acoustic guitar and drum kit across three zones of the keyboard (See illustration below).
- ORGAN I : Pipe organ sound.
- ORGAN II : Jazz organ sound.
- * STRINGS : String section.

* This voice uses keyboard velocity to change the attack and decay of the sound. With this function, staccato playing produces a sound with a rapid attack and decay, while legato playing results in a slower attack and decay.

* * The B/G/D Voice is assigned to the keyboard as follows:

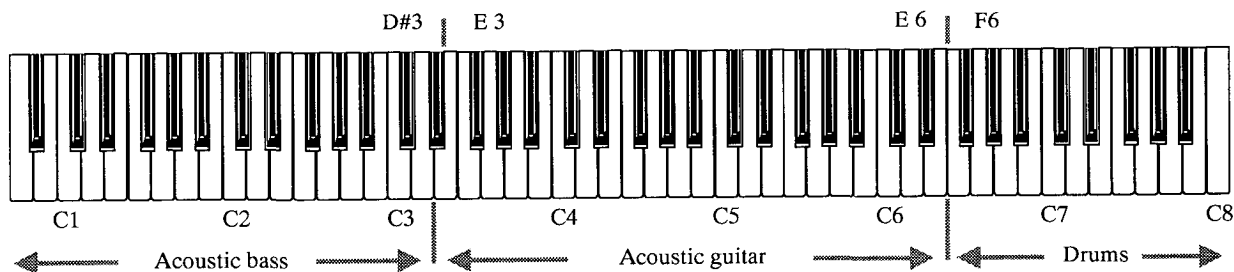

NOTE : The TRANSPOSE function can change the sound range for each of the above instruments.

The Drum voices are assigned as follows:

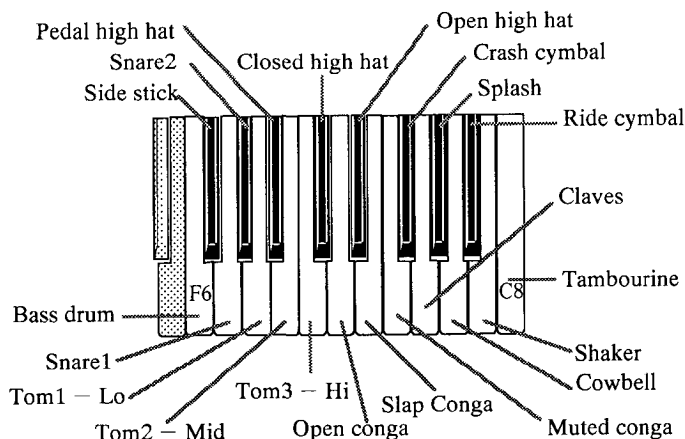

MIDI note number Programs(Instruments)

89 (59H)	Bass drum
90 (5AH)	Side stick
91 (5BH)	Snare1
92 (5CH)	Snare2
93 (5DH)	Tom1 - Lo
94 (5EH)	Pedal high hat
95 (5FH)	Tom2 - Mid
96 (60H)	Tom3 - Hi
97 (61H)	Closed high hat
98 (62H)	Open conga
99 (63H)	Open high hat
100 (64H)	Slap conga
101 (65H)	Muted conga
102 (66H)	Crash cymbal
103 (67H)	Claves
104 (68H)	Splash
105 (69H)	Cowbell
106 (6AH)	Ride cymbal
107 (6BH)	Shaker
108 (6CH)	Tambourine

Selecting effects

The C-56M offers the following three groups of effects. These groups may be combined to create many different sonic environments.

Note : The limit is one effect per group.

1. SURROUND

The four switches in this group add measured amounts of reverberation to simulate the ambience of different sized rooms.

- **ROOM** : Small room.
- **STAGE** : Medium-sized hall or auditorium stage.
- **HALL** : Large concert hall.
- **ECHO** : Delayed reflections.

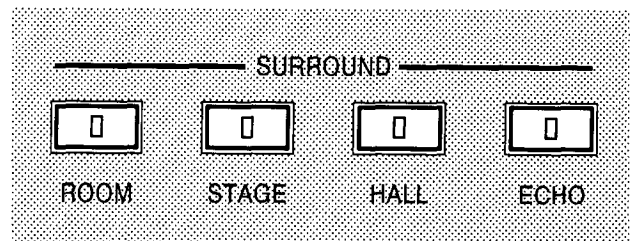

2. Modulation

The two switches in this group add modulation to produce a richer, fuller sound.

- **TREMOLO** : Rapid alternation between left and right audio channels.
- **CHORUS** : Slight detuning to make one instrument sound like many.

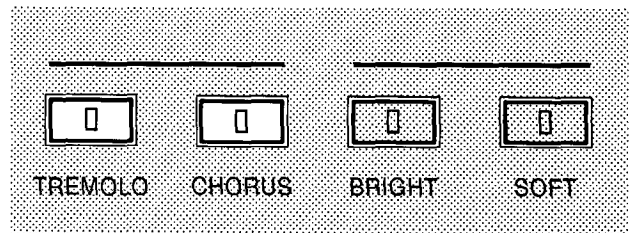

3. Equalizer

The two switches in this group add equalizer effects, which make the sound brighter or softer.

- **BRIGHT** : Emphasizes the high frequencies.
- **SOFT** : Cuts the high frequencies.

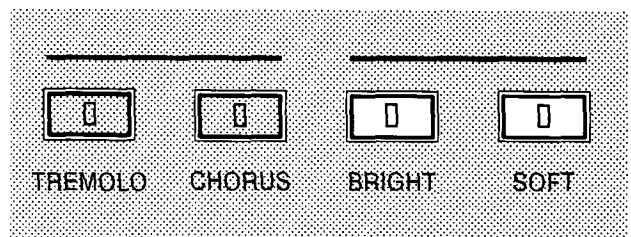

- Lines above the EFFECT SELECTOR switches divide them into three independent groups: SURROUND, MODULATION, and EQUALIZER effects. Pressing a switch changes the setting for that group only. You may add one effect from as many or as few groups as you wish.
- Pressing a switch with a lit LED indicator turns off the corresponding effect — and the effect group.
- Any changes that you make affect only the current voice. The new effect settings for that voice remain in effect through all subsequent voice changes until you change them — even if you turn off the C-56M.

Selecting Voice Modes

The C-56M provides three voice modes, two of which, LAYER and SPLIT, simultaneously use two different voices at the same time:

- **SINGLE** : This, the normal performance mode, uses one sound over the entire range of the keyboard.
- **LAYER** : This mode simultaneously uses two voices over the entire range of the keyboard.
- **SPLIT** : This mode divides the keyboard into two zones, upper and lower, each with its own voice.

Note: The LED indicators in the switches light to indicate which voice or voices are currently in use.

- **SINGLE** : Press a VOICE SELECTOR switch and every note across the range of the keyboard will sound the selected voice (for example, PIANO I).
- **LAYER** : Hold down one VOICE SELECTOR switch and press another (for example, PIANO II and HARPSICHORD) and every note over the range of the keyboard will sound both selected voices.

Note: Since the LAYER mode uses two voices simultaneously, maximum polyphony is reduced to sixteen notes.

- **SPLIT** : Press the appropriate VOICE SELECTOR switch to select the desired voice for the upper zone of the keyboard. Press the SPLIT switch to change to SPLIT mode. This automatically assigns a voice (the voice last selected in SPLIT mode) to the lower zone of the keyboard. To select a new voice for the lower zone of the keyboard, see “Changing Voices in Two-Voice Modes” below.

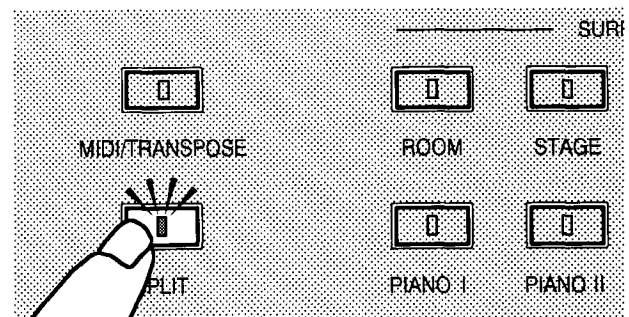
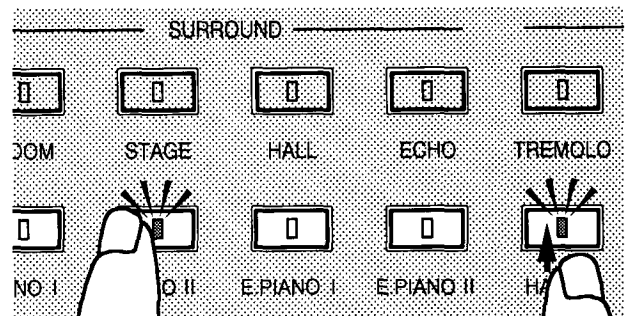

- To Cancel the LAYER mode and return to SINGLE mode, simply select a single VOICE SELECT switch.
- To Cancel the SPLIT mode and return to SINGLE mode, press the SPLIT switch to turn off its LED indicator.

Note : The C-56M returns to the previously selected upper keyboard zone VOICE.

Changing Voices in Two-Voice Modes

- To change voices in the LAYER or SPLIT mode, select a new voice or pair of voices.
- To change the voice for the upper zone of the keyboard in SPLIT mode, press another VOICE SELECTOR switch.
- To change both voices in the SPLIT mode, hold down the VOICE SELECTOR switch for the upper zone of the keyboard and then press the switch for the lower zone.

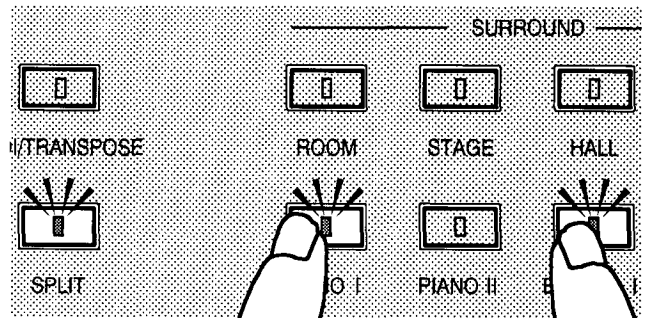

Changing the Octaves of Voices

Each of the upper and lower voices in Split mode can be transposed up to ± 3 octaves.

Transposing the lower zone's voice

To raise the lower voice one octave, press the A#0 key while pressing MIDI/TRANSCOPE switch.

To lower the lower voice one octave, press the A0 key while pressing MIDI/TRANSCOPE switch.

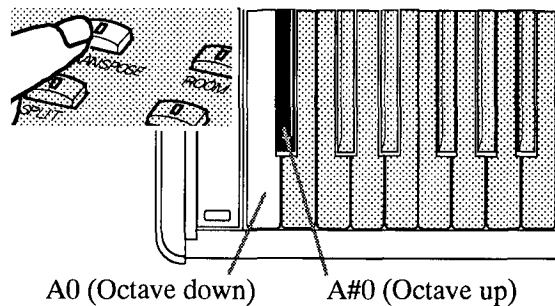

Transposing the upper zone's voice

To raise the upper voice one octave, press the C8 key while pressing the MIDI/TRANSCOPE switch.

To lower the upper voice one octave, press the B7 key while pressing the MIDI/TRANSCOPE switch.

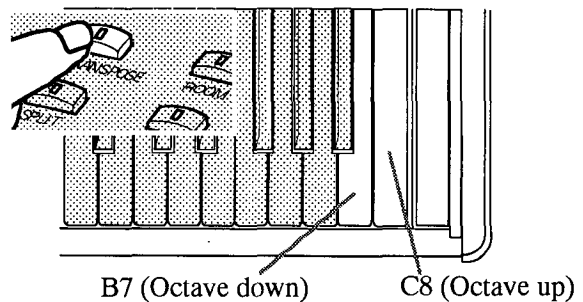

Note : Since the entire keyboard range of the C-56M lies between A0 and C8, the lowest octave will repeat in the lower ranges of the keyboard, and the highest octave will repeat in the higher ranges of the keyboard for as many octaves as you transposed.

Note : MIDI note number will not be affected by transposition. The transposed range(s) for both upper and lower voices will remain in effect after changing voices or leaving SPLIT mode. The transposed range(s) will return to normal after the unit has been turned off.

Changing the Split Point

The split point marks the boundary between the upper and lower zones of the keyboard. You specify its position by pressing the lowest key for the upper zone.

1. Switch to the SPLIT mode — if not already there.

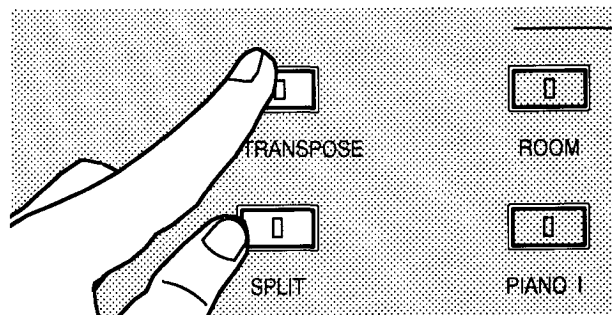

2. Hold down the MIDI/TRANSPOSE switch, press the SPLIT switch, and then press the key corresponding to the new split point.

Note : Any changes that you make affect only the current voice. The new split point and volume balance settings remain in effect through all subsequent voice changes until you change them.

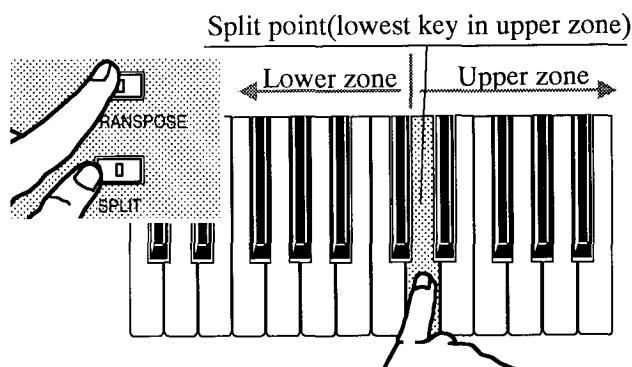

Adjusting the Relative Volume

Since the LAYER and SPLIT modes both use two voices, you may wish to adjust the relative loudness of the voices:

1. Switch to the SPLIT or LAYER mode — if not already there.
2. Hold down the VOICE SELECTOR switch corresponding to the voice that you wish to make softer.
3. Make the other voice louder by pressing the corresponding VOICE SELECTOR switch as often as necessary to achieve the desired balance.

Example: When selecting PIANO II and HARPSI

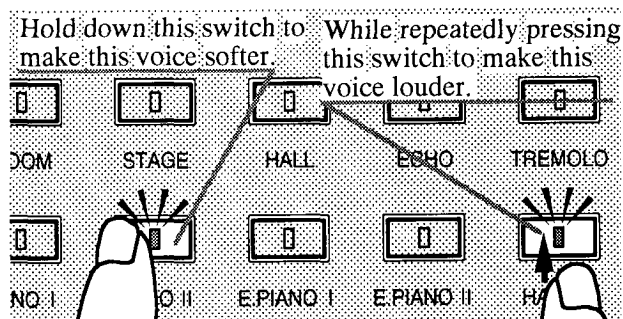

- Any changes that you make affect only the current voice. The new split point and volume balance settings remain in effect through all subsequent voice changes until you change them. Even after turning the unit off, the volume balance settings and the split point are retained in memory.

Using the Pedals

DAMPER

This pedal simulates the effect of a damper pedal on an acoustic piano. When the pedal is depressed on an acoustic piano, small felts, called dampers, are lifted from the strings. This allows all strings to vibrate, whether the key for those strings has been struck or not. When the pedal is released, strings vibrating without keys depressed are damped.

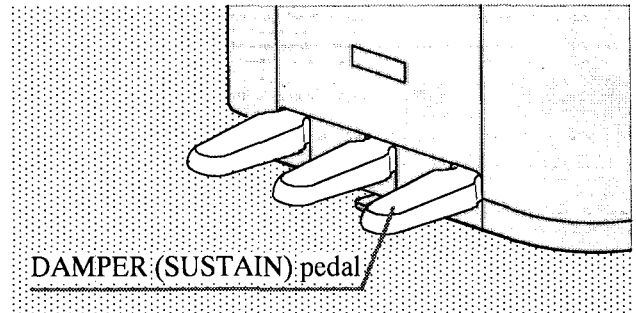

SOFT

This pedal simulates the effect of a soft pedal on an acoustic piano. When the pedal is depressed on an acoustic piano, the sound produced is softer, as the hammers strike one fewer string per key.

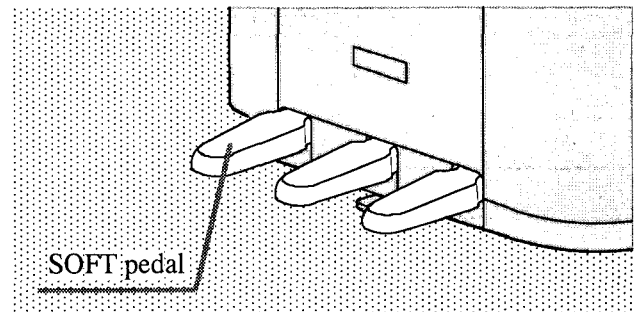

SOSTENUTO

This pedal simulates the effect of a sostenuto pedal on an acoustic piano. When this pedal is depressed on an acoustic piano, dampers for keys depressed when the pedal is depressed are suspended above the string until the pedal is released. This allows certain strings to vibrate freely while other strings are struck and damped by depressing and releasing keys.

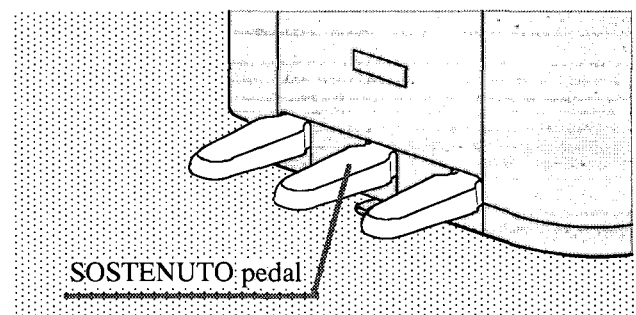

Using the Pedals with LAYER and SPLIT Mode

In the LAYER and SPLIT modes, the pedals may be used with just one voice or with both. To change between three possible pedal settings:

1. Hold down the MIDI/TRANPOSE switch.
2. Press the damper pedal.

Note : The changes are cyclical. (See illustration.)

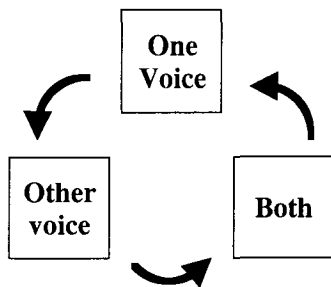

Note : The LED indicators in the VOICE selector switches light to indicate the voice or voices that use the pedals.

Note : The individual pedal settings for the LAYER and SPLIT modes remain in effect through all subsequent mode changes until you turn off the C- 56M . When the C- 56M is turned on, the pedals always start with the BOTH setting for the LAYER and SPLIT modes.

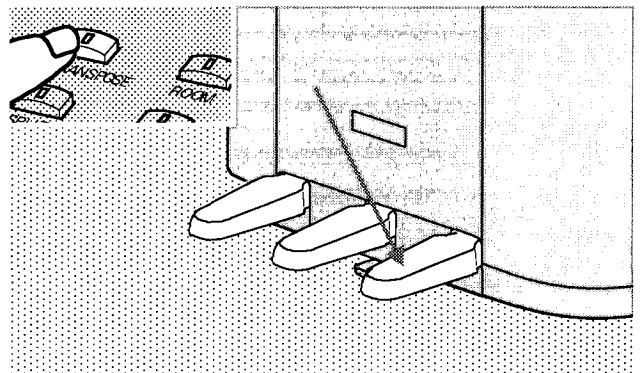

Note : Although the pedal settings are selected with the damper pedal, the setting selected affects all three pedals.

Changing Temperaments

In recent history, musical instruments have used a tuning system, or temperament, that divides an octave (for example, C4 to C5) into 12 equal steps, called half-steps or semitones. Before the 19th century, however, musical instruments made use of many different temperaments that were based on scales with different sized semitones.

The C-56M's voices can be assigned to an alternate temperament for realistic performance of early music. The two alternate temperaments are:

- **Kirnberger**
- **Werckmeister**

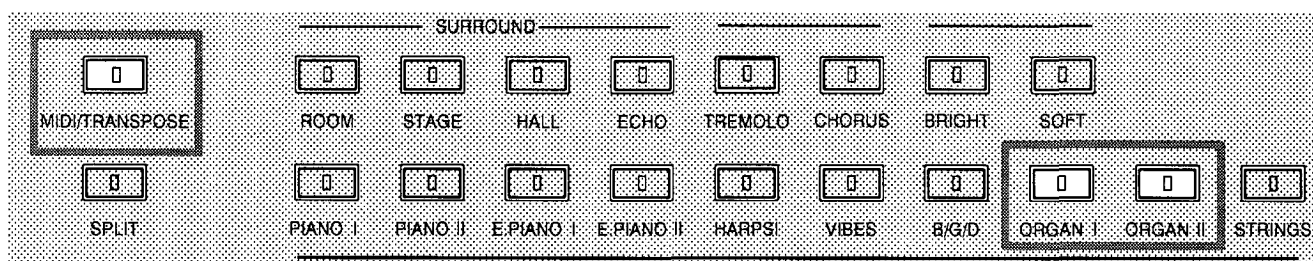

1. Hold down the MIDI/TRANPOSE switch to display the currently used temperament. The temperament is indicated by the lit or unlit ORGAN I and ORGAN II switches.

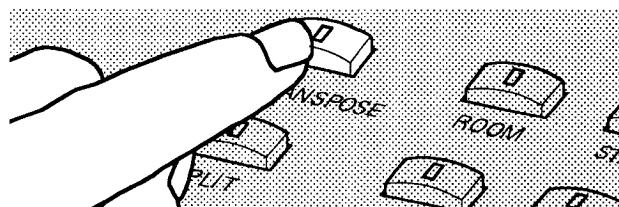

- ORGAN I only, Kirnberger temperament.
- ORGAN II only, Werckmeister temperament.
- Neither, Equal Temperament.

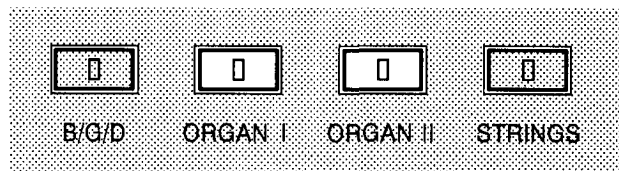
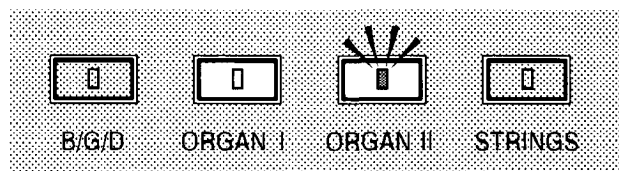
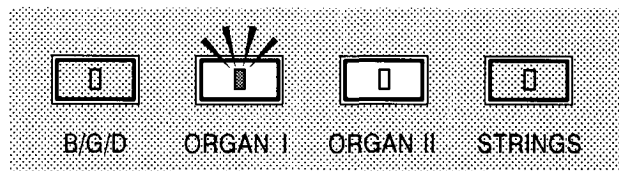

2. While holding down the MIDI/TRANPOSE switch, press the ORGAN I or ORGAN II switch to choose the desired temperament. The LED indicator representing the selected temperament will light.

Note : The temperament setting remains in effect through all subsequent use of the C-56M until you change it or turn it off. When the power is turned on, the C-56M begins with the Equal Temperament setting.

Touch Controls

The C-56M allows for the selection of a variety of touch responses that range from TOUCH 1 to TOUCH 3.

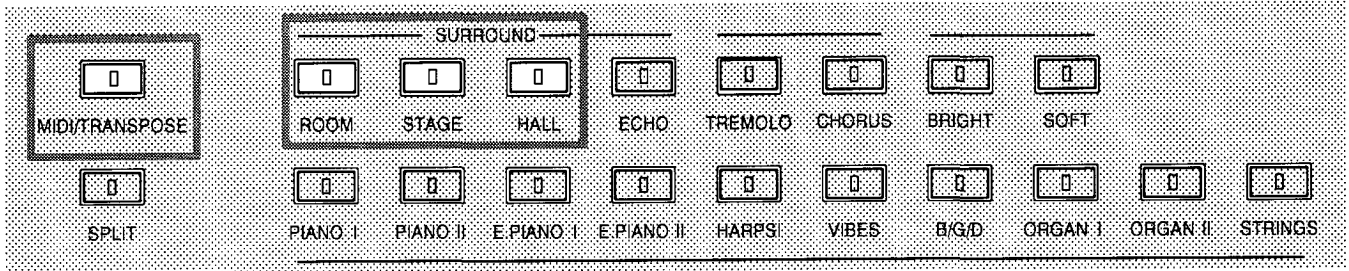

To select the desired touch, hold down the MIDI/TRANPOSE switch and press the corresponding EFFECT SELECTOR switches.

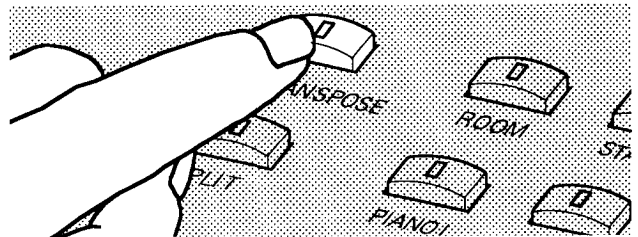

- **TOUCH 1**
Hold down the MIDI/TRANPOSE switch and press the ROOM switch.
- **TOUCH 2**
Hold down the MIDI/TRANPOSE switch and press the STAGE switch.
- **TOUCH 3**
Hold down the MIDI/TRANPOSE switch and press the HALL switch.

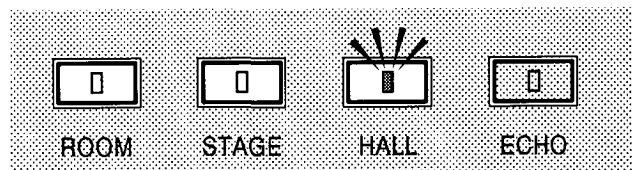
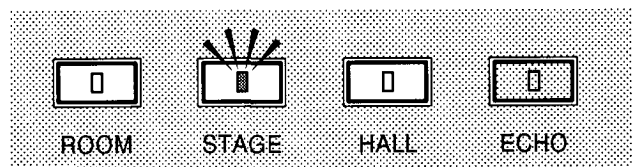
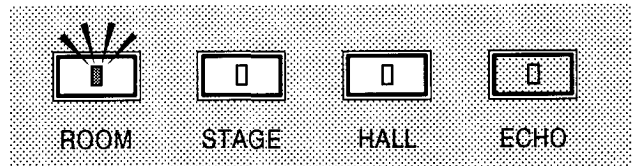

Whenever the power is turned on, TOUCH 1 is automatically selected.

Playing Demo Songs

The piano comes with pre-programmed demonstration songs. Use the following procedure to play back any desired song or all songs in succession.

Playing back a desired song

1. Hold the MIDI/TRANPOSE switch and press the START/STOP switch.

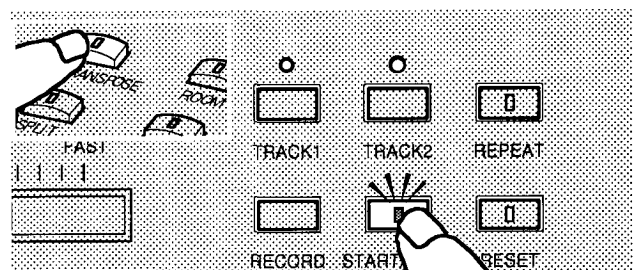

2. Several VOICE SELECTOR switches light up for a demo song to be selected.
- Voices cannot be changed with VOICE SELECTOR switches at this time.
3. Press any of the lit VOICE SELECTOR switches. The selected song will be played back.
4. At the end of the song, the piano automatically goes back to step 2 above.

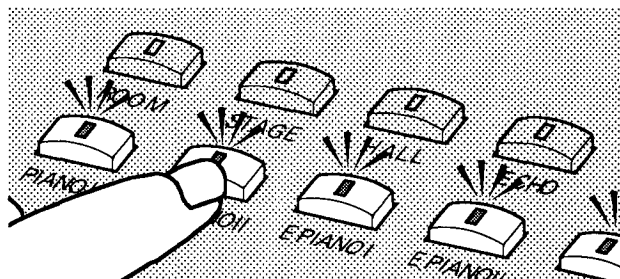

To stop playing the demo song,

To stop playing the demo song while it is being played, press the START/STOP switch. The demo song is cancelled and the piano will return to its normal setting. To cancel the demo song before it is played (in step 2 above), press the START/STOP switch twice.

Playing back all demo songs in succession

1. Hold the MIDI/TRANPOSE switch and press the START/STOP switch.
2. Press only the START/STOP switch again.
3. At the end of these songs, the piano automatically goes back to step 2 above.

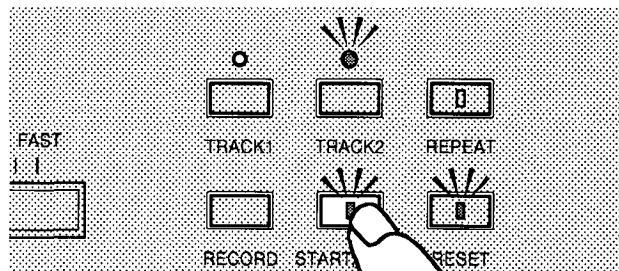

- You cannot use the record nor bounce functions while playing the demo song.

You can also repeat the demo song(s). Use the following procedure:

1. Turn on the REPEAT switch.
2. Hold the MIDI/TRANPOSE switch and press the START/STOP switch.

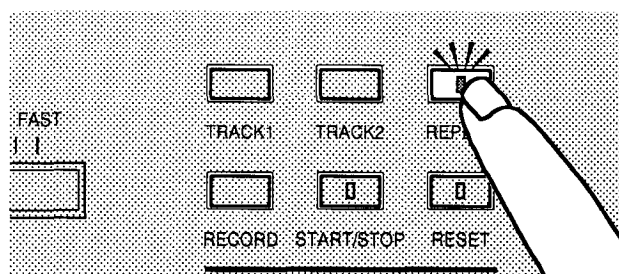

- After the REPEAT switch is pressed, selecting a single song will repeat the same song and selecting all songs will repeat all songs in succession.
- Demo songs can be set to repeat while they are being played. Simply press the REPEAT switch during playback.
- You cannot specify particular measures to repeat.

Changing Pitch : TRANSPOSE and TUNE

The TRANSPOSE function shifts the pitch of the keyboard up or down in semitones, or half-step intervals. The TUNE function moves the pitch up or down in smaller increments of pitch, called cents.

Note : When the power is turned on, the C- 56M is tuned to the standard key(C) and pitch (A4 = 440Hz).

TRANSPOSE Function

- The TRANSPOSE function changes the general key of the instrument, shifting the pitch up or down in semitones. The range of transposition is up a perfect fourth (5 semitones) and down a tri- tone (6 semitones). This function eliminates the need to change fingering when changing keys — making it easy to transpose to match a vocalist’s range, for example.

To transpose the keyboard:

1. Hold down the MIDI/TRANSPOSE switch.
2. Press a key between F#6 and F7 to select the interval of transposition.

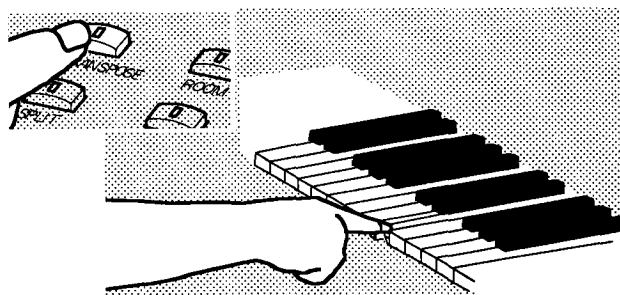

Note : The difference between the selected key and C7 becomes the new interval of transposition. Selecting a key below C7 transposes the key downward. Selecting a key above C7 transposes the key upward.

Note : The LED indicator in the MIDI/TRANSPOSE switch remains lit while the keyboard is in any key other than the original.

To **Cancel the Transposition** and restore the original key (C), just press the MIDI/TRANSPOSE switch and release.

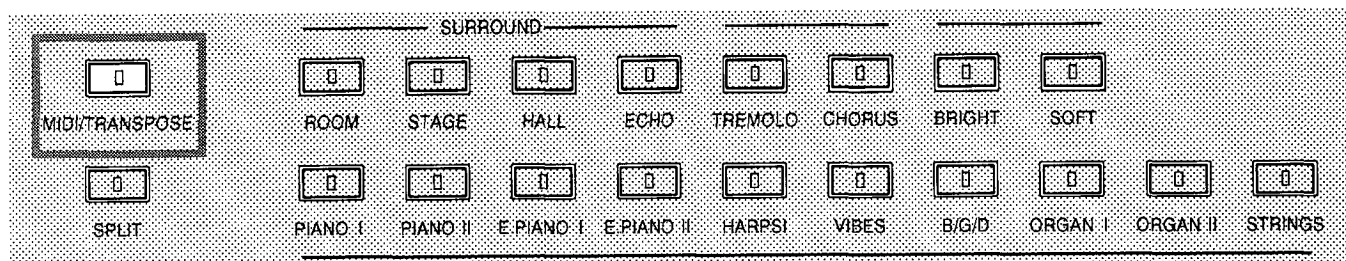

Key control (TRANSPOSE) keys: (F#6~F7)

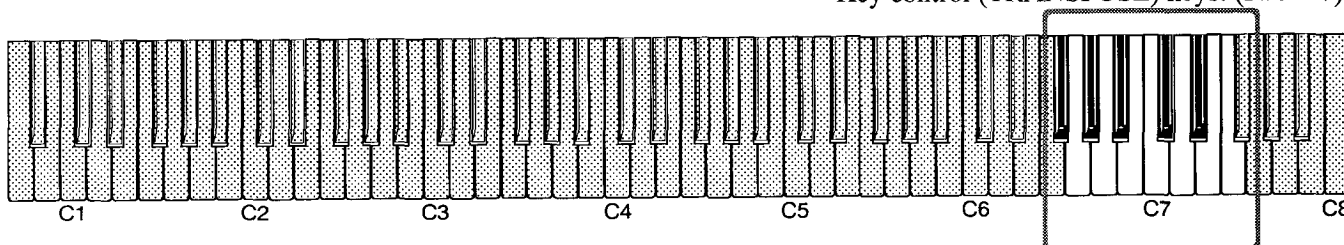

Example: Transposing up one half-step

While holding down the MIDI/TRANSPOSE switch, press C#7. This transposes the pitch of the instrument so that a piece played in the key of C will sound as if it is played in C#.

Transposing up one half-step

↓
The C7 key sounds as C#7

C#7

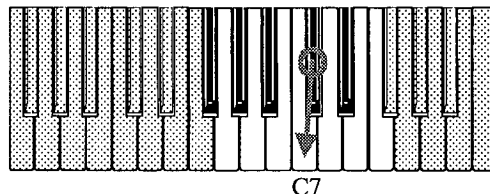

C7

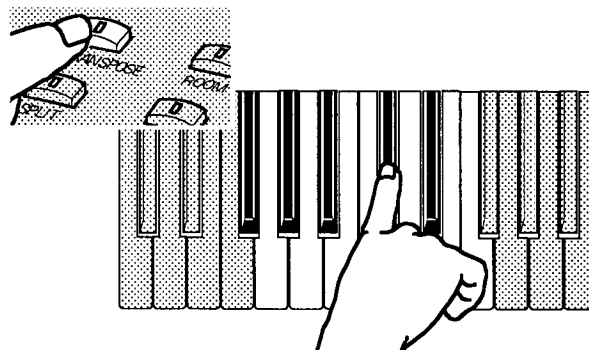
**Example:** Transposing down one whole-step

While holding down the MIDI/TRANSPOSE switch, press A#6. This transposes the pitch of the instrument so that a piece played in the key of G will sound as if it is played in F.

Transposing down one whole-step

↓
The C7 key sounds as A#6.

A#6

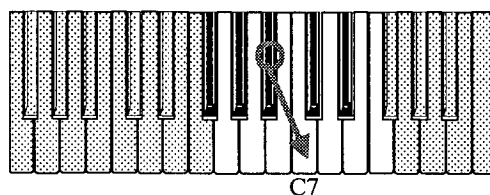

C7

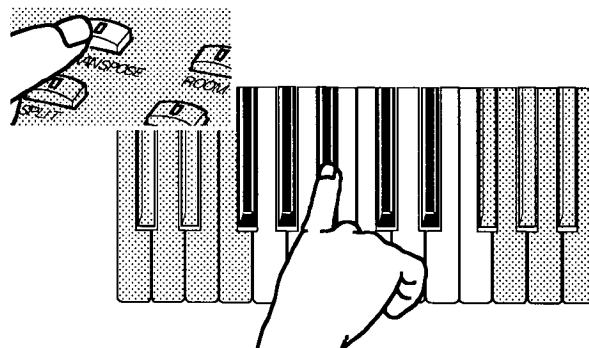

TUNE Function

- The TUNE function, which uses a much smaller increment of pitch, called cents, provides the ability to fine-tune the C-56M to another instrument. The range is 50 cents on either side of the standard pitch.

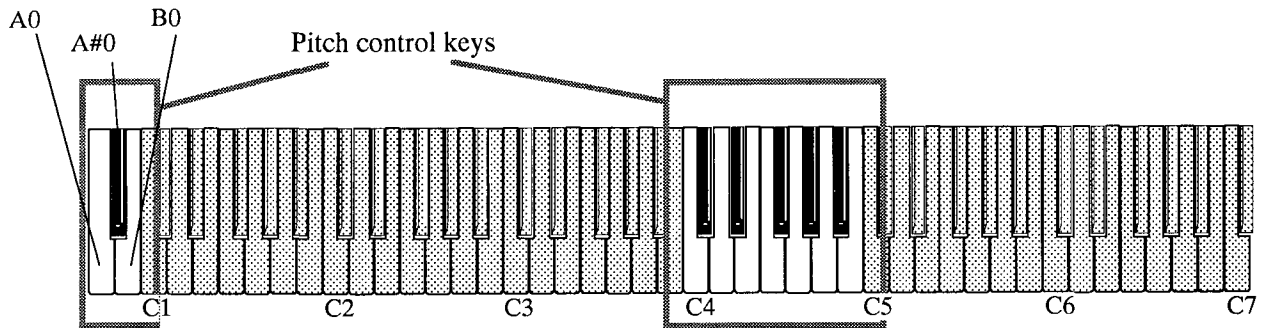

To fine-tune the keyboard:

1. Specify the tuning direction — up or down — by holding down the appropriate key combination at the lower end of the keyboard with your left hand:

UP Lowest two white keys (A0 and B0)
DOWN Lowest white and lowest black keys (A0 and A#0)

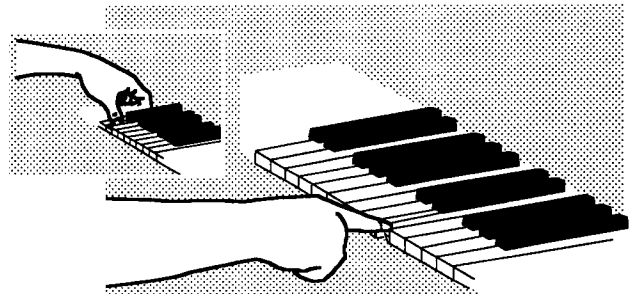

2. While holding the lower keys, press any key between C4 and B4 on the keyboard with your right hand to shift the pitch one step in the specified direction.

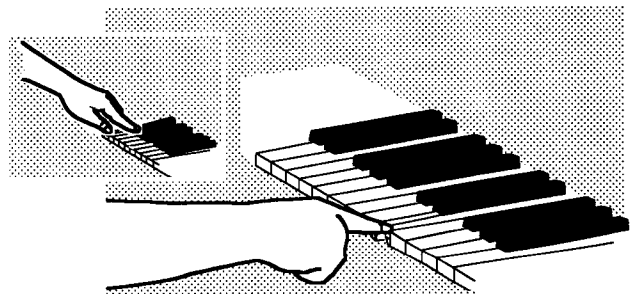

Note : One step is approximately 1 cent. The value can be changed over a range of ± 50 cents. (1 cent is 1/100 of a semitone.) The tuning will automatically return to the original setting (A4 = 440Hz) when the power is turned off.

Using the Built – In Recorder

The RECORDER section provides two built-in tracks for recording and playing back keyboard performances. Although it is similar in concept to a tape recorder, its digital design allows powerful features that surpass the capabilities of most tape recorders:

Tempo control : This makes it possible to control tempo without changing the pitch. Or changing the pitch without changing tempo. This feature allows a piece to be recorded at a slow tempo, and then played back at a faster tempo without changing the pitch.

Independent tracks : You can record two parts separately, one track at a time, and play back the tracks together or separately. You can also simultaneously listen to the playback of one track while recording the other, and even merge (or bounce) the data from both tracks onto a single track, thus freeing a track for additional recording. The recorder can merge a total of 15 times, providing a total of 16 tracks, each with its own voice (program) setting.

Note : You cannot send playback data to the MIDI OUT connector.

Note : Pressing the RESET switch instantaneously resets the recorder’s playback/record position to the beginning of both tracks. Although this function differs from that of a tape recorder’s rewind switch, the term “rewind” will be used to refer to the resetting of all tracks, for the rest of this manual.

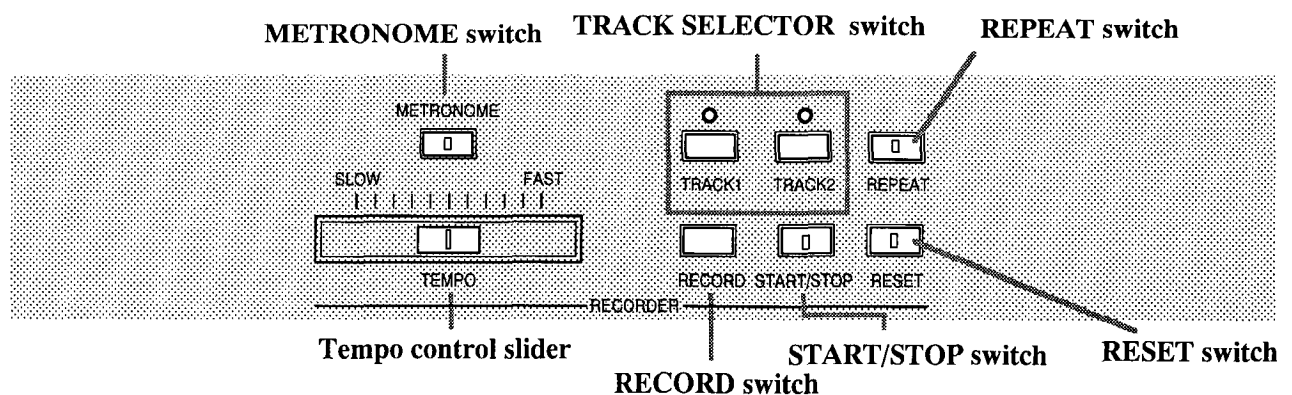

Recorder Controls

TRACK 1, TRACK 2

These switches specify the playback/record track(s). Pressing them individually or together prepares the recorder for playback. Pressing TRACK 1 or TRACK 2 with the RECORD switch will prepare the track to record.

Note : The recorder does not start actual playback/record until you press the START/STOP switch or, for recording only, a key on the keyboard.

Note : The LED indicators above the TRACK SELECTOR switches turn red to indicate recording and green for playback. A flashing red LED indicator warns that the recorder has already filled at least 90% of the available recording memory. Alternation between red and green by both LED indicators warn that the recorder is about to irreversibly alter both TRACK1 and TRACK2 (See “Merging Tracks” below).

TEMPO

The TEMPO slider changes the playback tempo, but not the pitch. Slide it to the left for slower playback, and to the right for faster playback.

Note : This control has no effect on the recording speed. The recorder samples the keyboard 360 times per second and records exactly what you play.

RECORD

Pressing the RECORD switch in combination with one of the TRACK SELECTOR switches puts the corresponding track on standby, ready to start recording when you press either the START/STOP switch or a key on the keyboard.

Note : The LED indicator above the TRACK SELECTOR switch turns red to indicate that the track is ready to record.

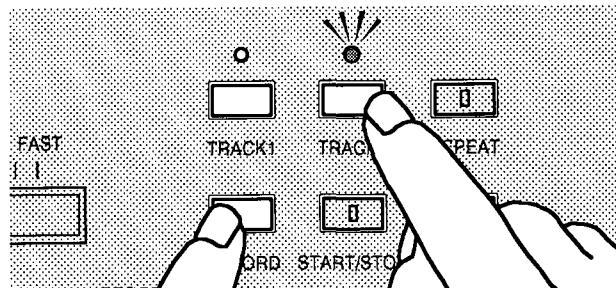

START/STOP

Alternately pressing the START/STOP switch starts and stops playback/record. The terms “stop” and “start” can also be interpreted as “pause” and “continue” – that is, pressing this switch does not terminate playback/record or rewind the recorder.

Note : The LED indicator inside the START/STOP switch lights when the recorder is actually recording or playing back a track.

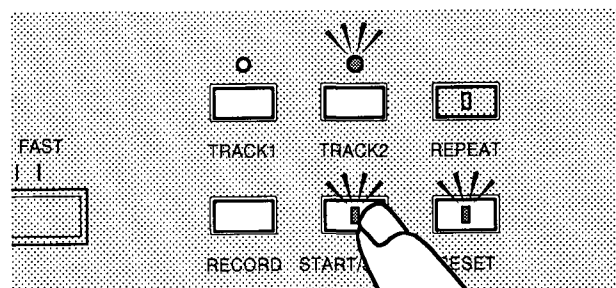

RESET

This switch rewinds the recorder and places the recorder on standby, ready to continue playback/record.

Note : The LED indicator inside the RESET switch lights whenever the recorder is anywhere other than the beginning of the track.

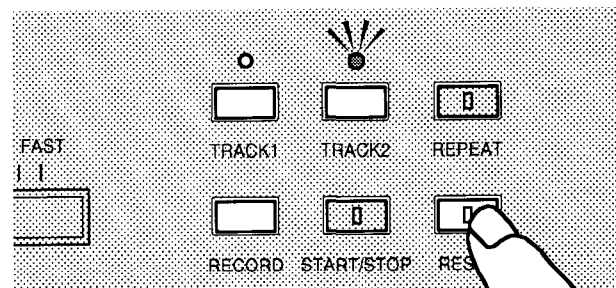

METRONOME

This switch controls the built-in metronome.

Note : The metronome is also available for use during regular keyboard use, not just during recording (See “Using the Built-in Metronome” on P. 34).

REPEAT

Pressing the REPEAT switch repeatedly plays back the selected measures of the track.

Basic Record/Playback Procedures

Recording a Track

To record a TRACK:

1. Hold down the RECORD switch and press one of the TRACK SELECTOR switches to specify the TRACK to record on.

Note : The LED indicator above the TRACK SELECTOR switch turns red to indicate that the track is ready to record.

2. Either press the START/STOP switch or start playing.

Note : The LED indicator inside the START/STOP switch and the RESET switch light to indicate that the recorder is running.

3. Press the START/STOP switch to stop the recorder.

Note : The LED indicator inside the START/STOP switch goes out to indicate that the record function has been stopped somewhere in the middle of the track.

4. (Optional) Press the RESET switch to rewind the recorder, turn off the LED inside the switch, and put the recorder back on standby, ready to record the same track all over again.

5. (Optional) Go back to Step 2 above.

6. Press the RECORD switch to terminate recording and rewind the recorder by pressing the RESET switch.

7. Record the other track or play back the current track with the procedure given below.

Note : Voices cannot be changed during the recording of a TRACK.

If a voice change is made while recording, the program changed will be ignored in playback.

Reading the Memory Usage Gauge

The recorder's memory capacity is finite. To determine how much memory remains, hold down the RECORD switch and read the LED indicators in the VOICE SELECTOR switches. Together they form a rough memory usage gauge similar to a car's gasoline gauge or a tape recorder's VU meter. The number of LED indicators that light increases as the tracks accumulate more data.

Note : When less than 10% of total memory remains, the red LED indicator above the TRACK 1 SELECTOR switch begins to flash.

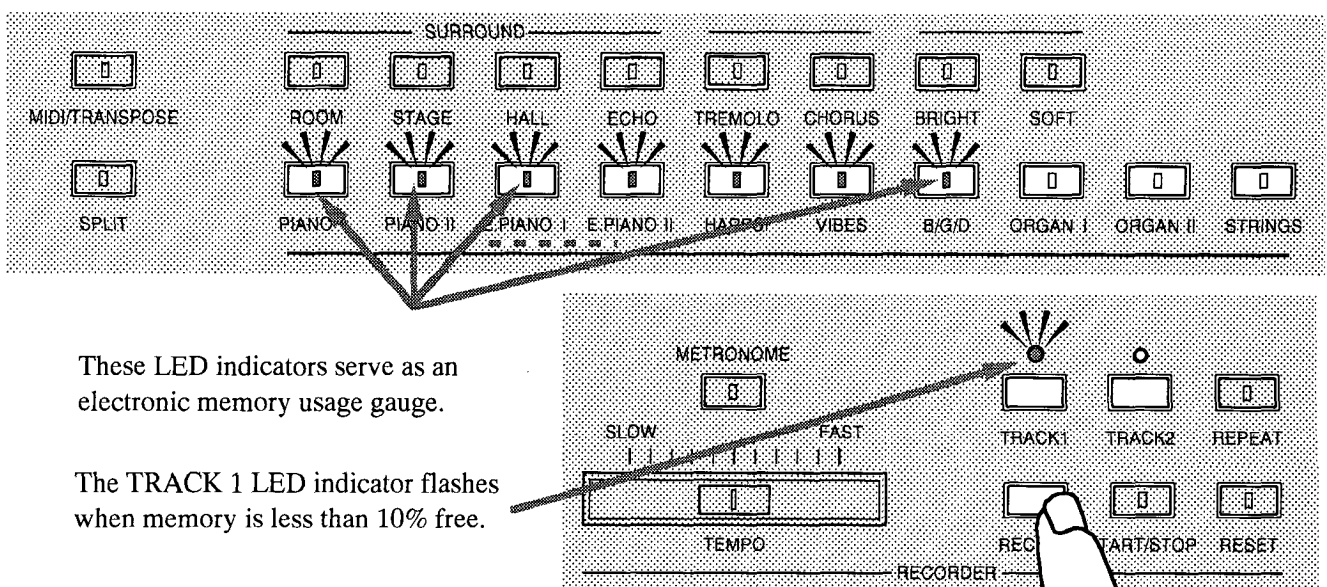

Playing Back a Track

The procedure for playing back a track is similar to the procedure for recording a track.

To play back a TRACK:

1. Press one of the TRACK SELECTOR switches to specify the TRACK to be played back.

Note : The LED indicator above the TRACK SELECTOR switch turns green to indicate that the track is ready to play back.

2. (Optional) Release that TRACK SELECTOR switch and press the other TRACK SELECTOR switch to simultaneously play back both tracks.

Note : Do not press the two TRACK SELECTOR switches simultaneously. This would put the Merge function on standby and possibly result in the erasure of one of the tracks. (See the section “Merging Tracks” below.)

3. (Optional) It is possible to begin playback either from the start of a track or from the point where the recorder was stopped. The RESET switch lights up whenever the recorder is anywhere other than the beginning of the track. Simply press START/STOP to resume playback from that point or press the RESET switch to rewind the recorder to the beginning, then press START/STOP to begin playback.

4. Press the START/STOP switch to resume playback.

Note : The LED indicator inside the START/STOP switch lights to indicate that the recorder is playing back.

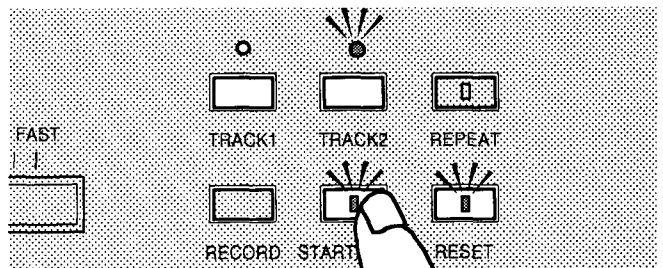
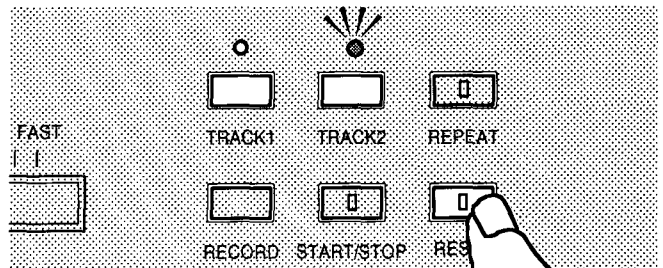
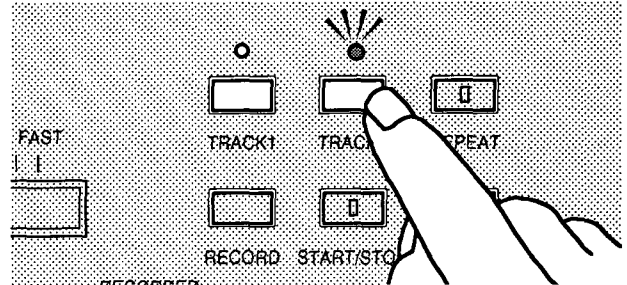

- (Optional) Adjust the tempo.

Note : The TEMPO control slider remains operational throughout this entire procedure.

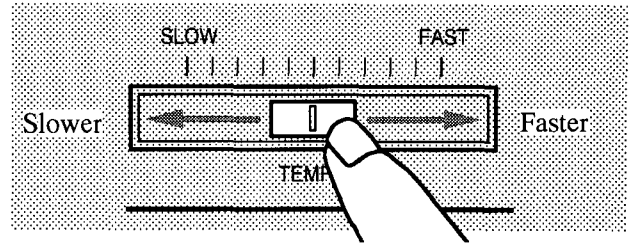

- Press the START/STOP switch to stop the recorder.

Note : The LED indicator inside the START/STOP switch goes out, and the LED indicator inside the RESET switch will be lit to indicate that the recorder is stopped somewhere in the middle of the track (or tracks).

- (Optional) Go back to Step 2 above.

Advanced Recorder Procedures

Repeating Playback

If necessary, you can choose to repeatedly play back all or a specific part of a recorded track. This feature is especially useful for practicing difficult pieces or parts.

Note : Select a part of the track to be repeated by specifying the starting measure and the ending measure. You cannot specify the middle of a measure as the starting or ending point.

- Press the TRACK SELECTOR switch for the track you wish to repeat. The LED indicator above the TRACK SELECTOR switch turns green to indicate that the track is ready to playback.

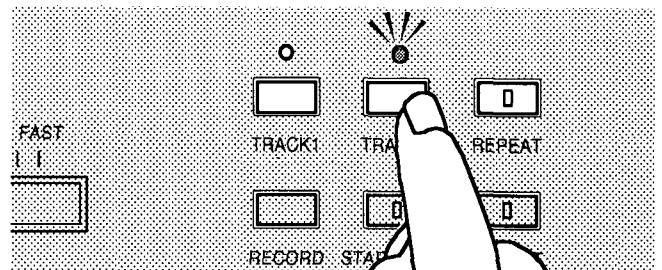

- Press the REPEAT switch. The LED inside the REPEAT switch lights.

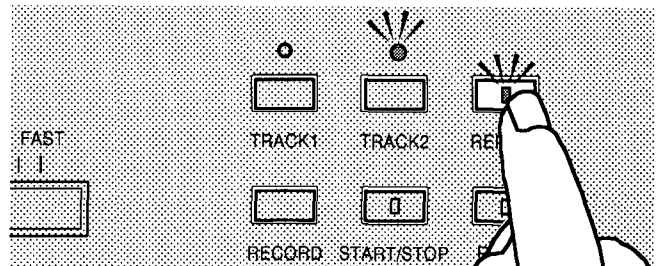

3. Press the START/STOP switch. If a repeating part of the track is already selected, the recorder will play back only the selected part. If a repeating part of the track is not selected, the recorder will play back the entire track.

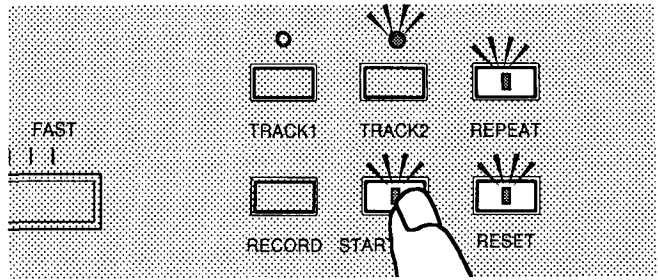

To repeat the entire track:

1. Press the TRACK SELECTOR switch for the track you wish to repeat. The LED indicator above the TRACK SELECTOR switch turns green to indicate that the track is ready to play back.
2. Make sure the recorder is currently stopped and the recorder is at the beginning of the track (press the RESET switch). Hold down the MIDI/TRANPOSE switch and press the REPEAT switch. The LED indicator inside the REPEAT switch lights to indicate that the starting measure has been selected.
3. If you do not select an ending measure, the recorder will automatically select the last recorded measure as the end of the repeated section.

To repeat a part of the track:

1. Press the TRACK SELECTOR switch for the track you wish to repeat. The LED indicator above the TRACK SELECTOR switch turns green to indicate that the track is ready to play back.

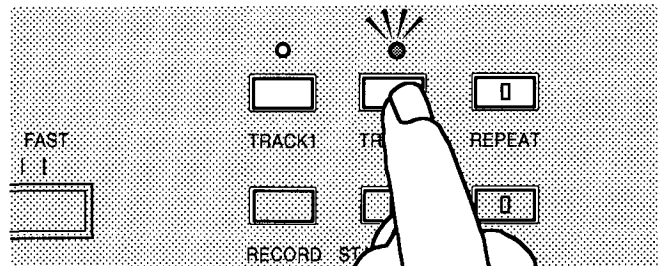

2. Press the START/STOP switch to play back the track.

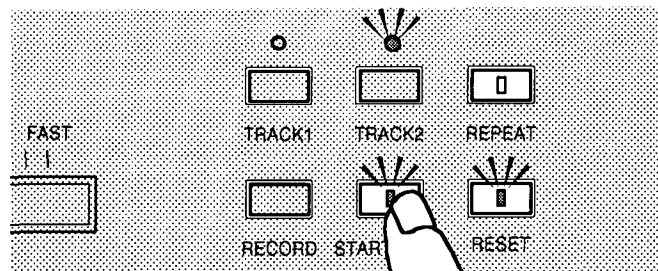

3. When the track reaches the measure at which you wish to begin the repeat, hold down the MIDI/TRANPOSE switch and press the REPEAT switch. The LED indicator inside the REPEAT switch lights to indicate that the first measure of the repeated section has been selected.

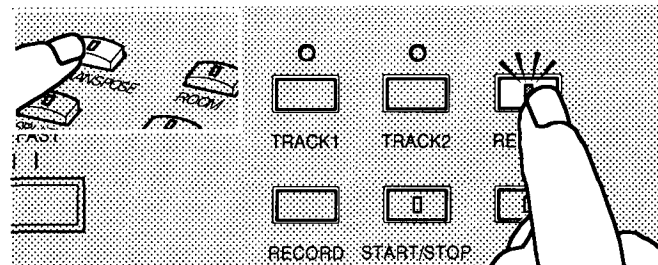

4. Continue playing back. When the track reaches the measure at which the repeated section is to end, hold down the MIDI/TRANSPPOSE switch and press the REPEAT switch again. The LED indicator inside the REPEAT switch goes off to indicate that the final measure of the repeated section has been selected. Release the REPEAT switch. The LED indicator inside the REPEAT switch lights and the recorder begins to repeat playing back the specified measures.

Note for playing the repeated section

1. If the REPEAT switch is pressed while the recorder is playing between the beginning of the TRACK and the first measure of the repeated section (① in the illustration to the right), the recorder will play from the current measure to the last measure of the repeated section and then commence repeated playing of the selected measures (② in the illustration to the right). If the REPEAT switch is pressed while the recorder is playing between the first and last measures of the repeated section (② in the illustration to the right), the recorder will play to the last measure of the repeated section and then commence repetition of section ②.
2. If the REPEAT switch is pressed while the recorder is playing between the final measure of the repeated section and the end of the TRACK (③ in the illustration to the right), the recorder will continue to play to the end of the TRACK then replay the TRACK from the beginning of the TRACK to the last measure of the repeated section then commence repetition of section ②.
3. When the RESET switch is pressed, the recorder will play the TRACK from the beginning through the last measure of the repeated section and then commence repetition of section ②.

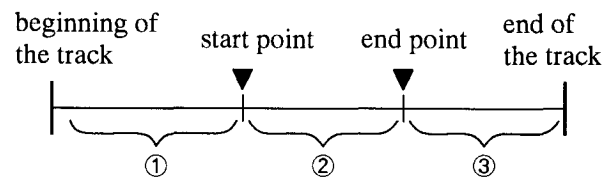

Cancelling the repeating measures:

- Cancelling the repeating measures sets the recorder to repeat playing back the entire track.

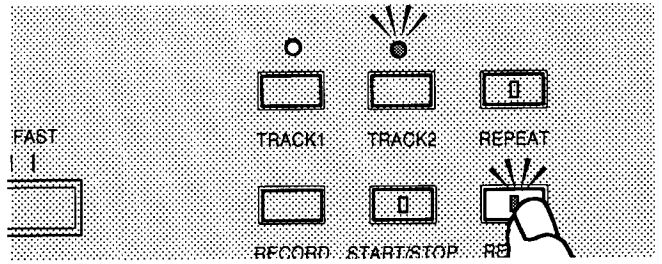

1. Make sure the recorder is currently stopped and press the RESET switch.

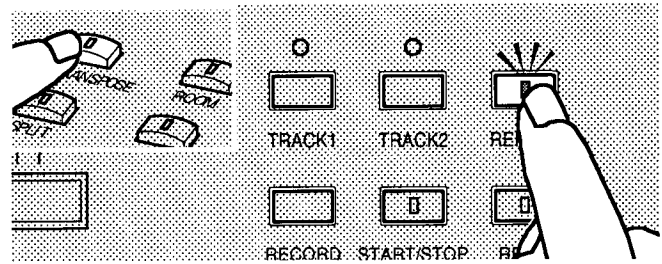

2. Hold down the MIDI/TRANSPOSE switch and press the REPEAT switch. The LED indicator inside the REPEAT switch lights to indicate that the first measure of the repeated section has been cancelled.

3. While the recorder is stopped, hold down the MIDI/TRANSPOSE switch and press the REPEAT switch again. The LED indicator inside the REPEAT switch goes off to indicate that the last measure of the repeated section has been cancelled.

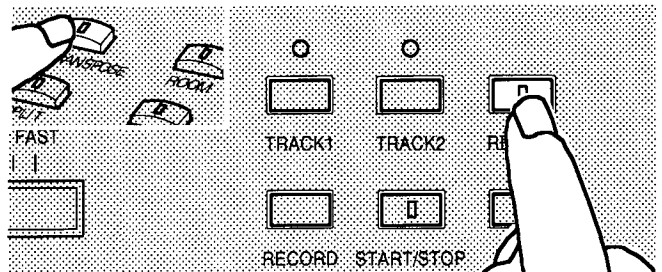

- You can set one repeating part for each of the two tracks.
- The repeating part of the track will be saved to the C-56M's memory even after the unit is turned off.

- The repeating part of the track will not be in effect on a re-recorded track or a merged track.

Putting the Recorder to Work

The techniques below represent easy-to-use procedures for recording and playback. The first two techniques show how to record two separate parts of a single performance. Below, "parts" can mean anything from just the left and right hand parts of a simple piece, to primo or secondo parts of a four-hand composition. Since the parts are recorded onto independent tracks, they can also use different voices. Together, these techniques allow you to listen to one track while recording another, building a performance in which two separate parts form a seamless whole. Since repeated recording of entire tracks is unnecessarily time-consuming, the recorder allows you to start re-recording anywhere in a track. (See "Cuing a Track for Re-Recording" below.) Once the two parts have been finished, they can be merged onto a single track, thus freeing one track for additional recording (see "Merging Tracks" below).

Simultaneously Playing Back Both Tracks

To play back both Tracks at the same time, press the TRACK1 and TRACK2 buttons separately, then press START/STOP.

Note: There is, however, a 32 note limit on the total number of simultaneous notes.

Simultaneous Recording and Playback

The important step is changing track specifications to “record” instead of “playback”:

Note: Although there are two possible arrangements, using TRACK2 for playback and TRACK1 for recording is usually safest because, after merging the first two tracks, it is impossible to reverse the arrangement without loosing TRACK2 data. (See “Merging Tracks” below.)

1. Press the TRACK SELECTOR switch for the track that contains data.

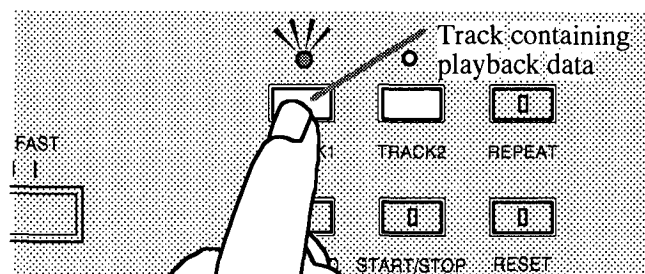

2. Hold down the RECORD switch and press the other TRACK SELECTOR switch.

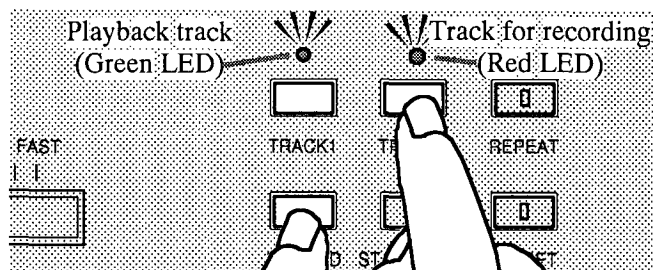

3. (Optional) Press the RESET switch to rewind the recorder.

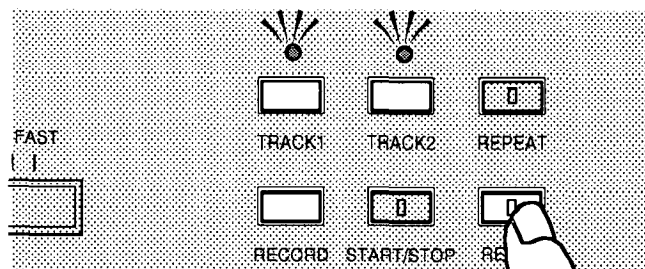

Note : Alternatively, you may choose to continue playback/recording from the current position. (See next procedure.)

4. Continue using a combination of the standard playback/recording procedures.
5. After recording, simultaneously play back both tracks to review the results.

“Punching In”(Cueing a Track for Re-Recording)

As mentioned above under “RECORDER Controls,” pressing the START/STOP switch does not rewind the recorder. Subsequent discussions concentrate on its role as a “PAUSE/CONTINUE” switch during playback/record, but such a pause provides an ideal opportunity to switch from playback to recording and thus save having to re-record everything up to that point.

Note: Although the START/STOP switch provides an ideal opportunity to begin re-recording in the middle of a TRACK, care must be taken when beginning to record over old performance data. Make sure to begin re-recording in time (or in tempo), otherwise slight discrepancies may occur in inter-track synchronization. The key is switching from playback to recording at the appropriate point in the music:

1. Use the regular playback procedure to re-play the TRACK.
 2. Press the START/STOP switch to stop playback at the desired transition point.
 3. Hold down the RECORD switch and press the same TRACK SELECTOR switch to activate recording.
 4. Either press the START/STOP switch or start playing.
 5. Use the regular recording procedure to replace the existing track data with new data.
- It is also possible to record music onto the end of an existing song by playing back the already recorded song to its end and switching to the record function.

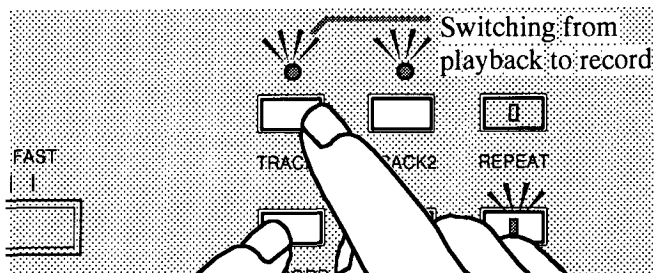

The procedure is as follows:

1. Use the regular playback procedure to play the selected TRACK back.
The START/STOP switch will go out and playback will stop at the end of the TRACK.
2. Hold down the RECORD switch and press the TRACK SELECTOR while the RESET switch's LED indicator is lit.
The lamp on the selector will change from green to red to indicate that the function has switched from playback to recording.
3. Press the START/STOP switch or play to start recording from the end of the song.

Note : Using the START/STOP switch to stop in the middle of playback and switch to recording will sometimes cause the newly recorded material to begin at a slightly different place from where playback was stopped.

Note : Any voice changes made in the newly recorded material will be ignored when the material is played back. The voice selection made in the original or first recording of the song will be in effect for playback of the entire song, including the appended material.

Note : When cueing a TRACK for re-recording, the data for the remainder of the TRACK will be lost. The remainder of the TRACK, to the end, must be re-recorded.

“Multi- Track Recording”(by Merging Tracks)

Although the built-in recorder has two TRACK SELECTOR switches on the front panel, it is possible to record a total of 16 tracks by merging the finished TRACKS together. When merging TRACKS, it is also possible to combine TRACKS with different voice settings.

For example, it is possible to record a part on TRACK 1, merge TRACK 1 data with TRACK 2 (which clears TRACK 1), and then record a new part on TRACK 1.

Note : To produce a 16-track recording, record the first track on TRACK 2. Remember, however, the total number of notes that can be played simultaneously is limited to 32.

To merge the two tracks:

1. Simultaneously press both TRACK SELECTOR switches.

Note : The LED indicators above the TRACK SELECTOR switches will alternately flash in red and green to warn against inadvertent merging of the tracks.

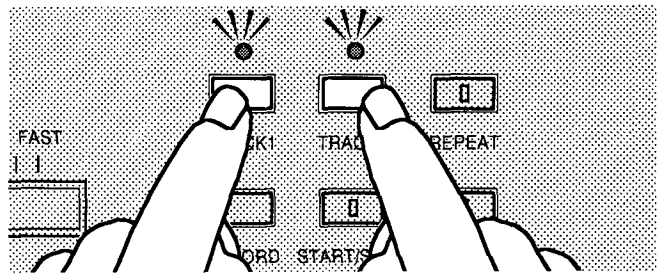

2. Press the START/STOP switch to proceed or a single TRACK SELECTOR switch to cancel.

Note : It is impossible to STOP playback, cue and re-record in the middle of a merged TRACK. However, it is possible to switch to record and add material at the end of a merged track.

Erasing a TRACK

Although there is no erase function, beginning to re-record a TRACK automatically erases the data for the entire TRACK.

1. Choose a TRACK to erase.
2. Hold down the RECORD switch while pressing the TRACK SELECTOR switch of the TRACK to be erased.
3. Press the START switch and wait until recording commences before pressing STOP (do not START the recorder by pressing a key on the keyboard, as note data will be recorded).
4. If you intend to record data on another track, the “erased” track should not be turned on.

- It is possible to operate a sequencer, drum machine and other external MIDI devices in synchronization with the C-56M's built-in recorder. For details, see “Synchronizing with external MIDI devices.”

Using the Built-In Metronome

The C-56M has a built-in metronome. It is capable of accenting particular beats, or groups of beats. This feature allows the metronome to keep time in different meters.

Note: The metronome sounds through the built-in speakers and headphones. The volume of the metronome is unaffected by the VOLUME control slider.

METRONOME

Pressing this switch alternately starts and stops the metronome.

Note : The LED indicator inside the switch lights when the metronome is on.

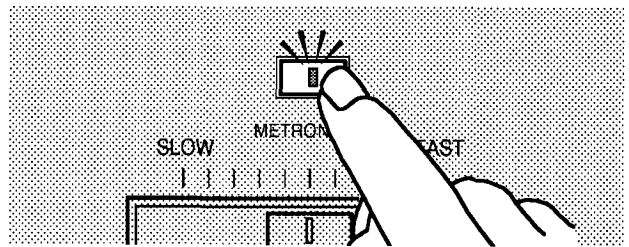

Metronome Controls

TEMPO

Sliding this control to the left slows the metronome; sliding it to the right speeds it up.

Note : When the metronome is on, the maximum polyphony is decreased to thirty-one notes.

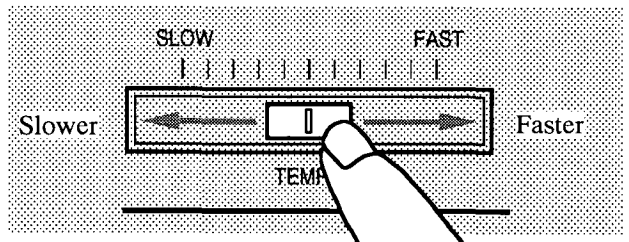

Pattern Selector Switches

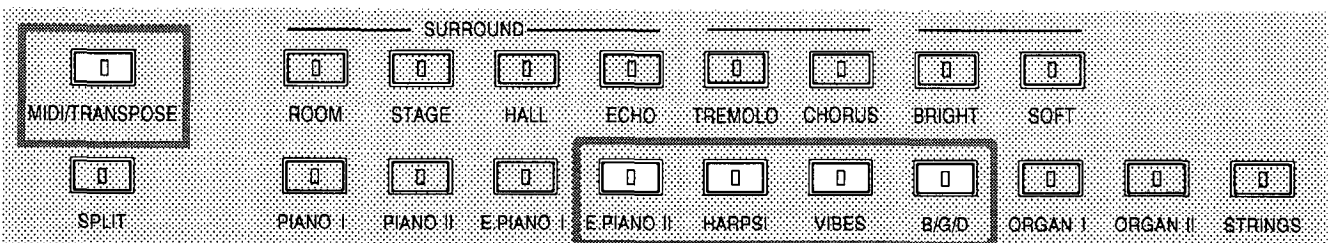

These switches, in combination with the MIDI/TRANPOSE switch, determine the beat pattern.

Note : Alternate presses turn the LED indicator inside the switch on and off.

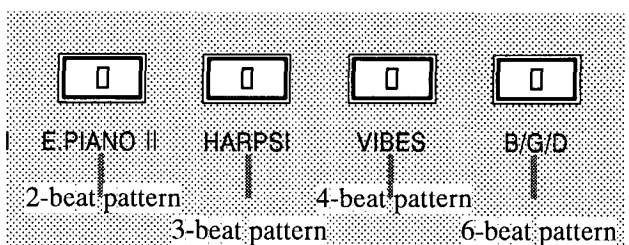

MIDI/TRANSPOSE switch

Holding down this switch activates the pattern selector switches and lights the LED indicator for the current setting.

Note : If no LED indicator lights, the pattern is unaccented.

Trying Out the Metronome

1. Press the METRONOME switch to start the metronome.

Note : The LED indicator inside the switch lights to indicate that the metronome is on.

2. Use the TEMPO control slider to adjust the tempo.

3. Hold down the MIDI/TRANSPOSE switch, and press one of the pattern selector switches to select the appropriate meter.

Note : The LED indicator inside the switch lights to indicate the new beat pattern.

4. Hold down the MIDI/TRANSPOSE switch, and press the same pattern selector switch to change back to the unaccented beat pattern.

Note : The LED indicator inside the switch goes out.

- When the piano is turned on, the metronome is set to the unaccented beat pattern.

Using the MIDI Functions

What is MIDI?

MIDI stands for **Musical Instrument Digital Interface**, an internationally recognized standard for connecting electronic musical instruments, personal computers, and other electronic equipment so that they may communicate with one another and thus work together as a single MIDI network. You may, for example, connect the C-56M to a synthesizer and play both instruments together as an ensemble from a single keyboard, or connect with a MIDI sequencer to play different voices on various MIDI instruments. The discussion below describes how to use the C-56M's MIDI controls. For further details, consult the manuals included with your synthesizer, drum machine, or other MIDI equipment or any of the fine reference materials now available.

The C-56M has MIDI IN, MIDI OUT and MIDI THRU terminals on the rear panel. The MIDI OUT terminal is used for sending MIDI data whereas the MIDI IN is used for receiving MIDI data from external devices. The MIDI THRU port is used for sending a copy of the MIDI data received at the MIDI IN port to another MIDI capable instrument.

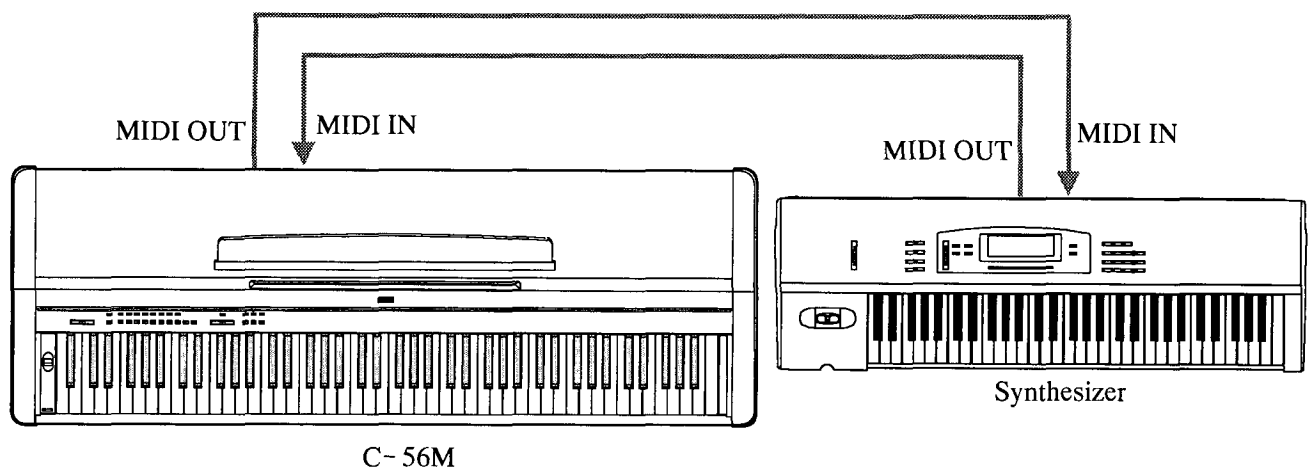

MIDI Controls

Various MIDI functions can be selected by holding down the MIDI/TRANSCOPE switch and pressing certain VOICE SELECTOR switches and keys on the keyboard.

Note : The current MIDI settings are displayed by the LED indicators.
 These settings are in effect when the C - 56M is turned on.

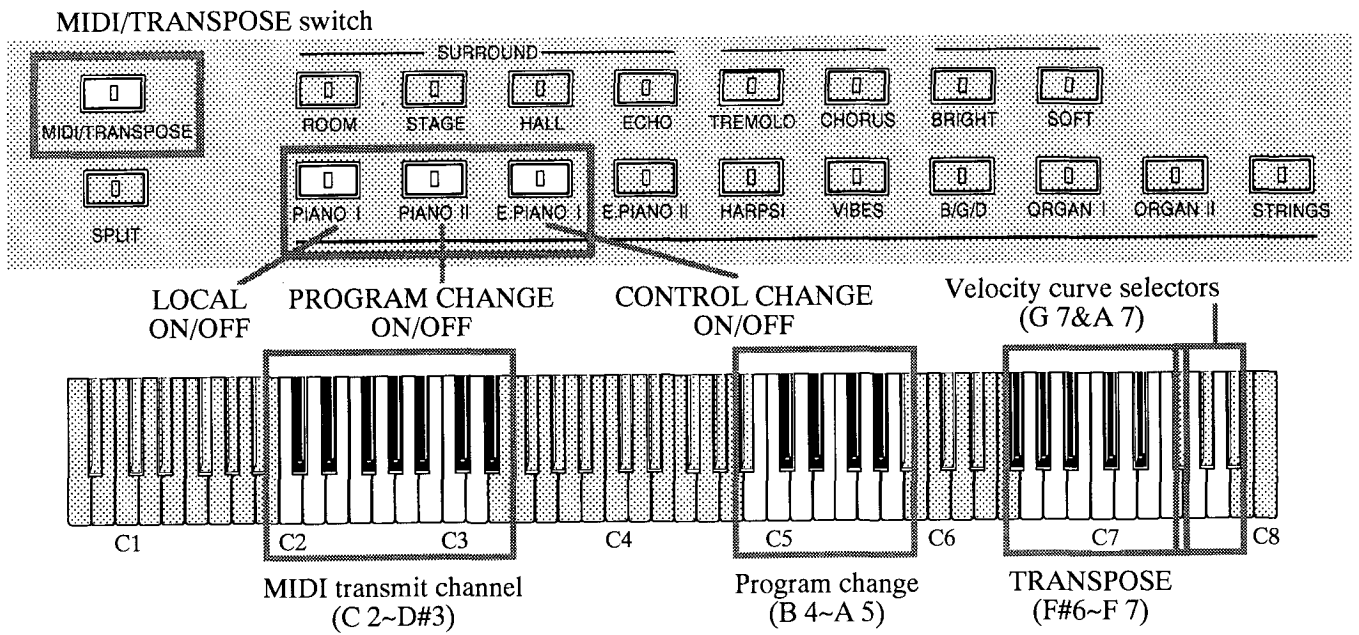

MIDI Default Values

When the power is turned on, the C - 56M defaults to the following MIDI settings.

- MIDI transmission channel 1
- MIDI receiving channel 1 (See "MIDI MULTI Function" below)
- LOCAL ON
- PROGRAM CHANGE ON
- CONTROL CHANGE ON

1. Changing the MIDI Transmit Channel

The MIDI standard provides 16 separate channels for the transmission of performance data. MIDI master keyboards (controllers) can therefore control up to 16 individual slaves (or groups of slaves acting in unison) by sending channel messages. Performance data messages always include a channel number. Each device on the network reads all messages, but only responds to messages that match the connected instrument's MIDI receive channel.

Note : There are also system messages, which have no channel numbers because they are intended for all devices. The most important are the timing messages that synchronize networks.

To change the MIDI transmit channel, hold down the MIDI/TRANPOSE switch and press the appropriate key between C2 and D#3. (See Figure.)

Note : When the power is turned on, the C - 56M is set up to transmit on channel 1.

MIDI transmit channel

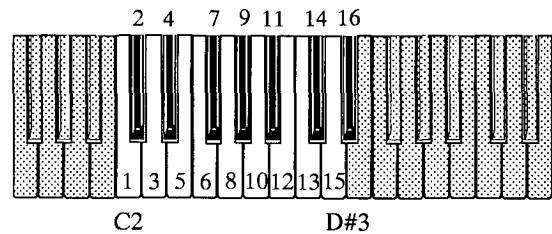

Note : Sequencers and other MIDI recording devices also have an OMNI mode which allows them to simultaneously receive performance data on all channels.

Example: Changing to MIDI channel 14.

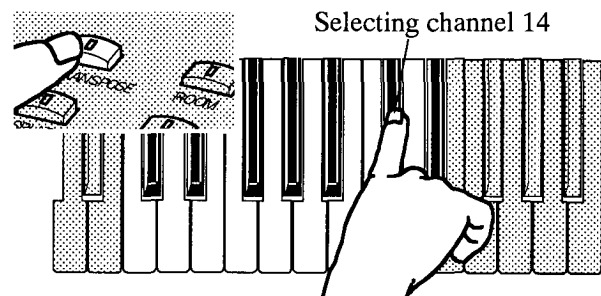

Transmitting channel is 14 and receiving channels are 14, 15 and 16. (See MIDI Multi function.)

2. Changing the LOCAL ON/OFF Setting

The LOCAL ON/OFF setting allows you to use the C - 56M as a "silent" MIDI controller. When LOCAL is set to OFF, the C - 56M's internal voices will not sound, and only the sounds of the connected MIDI devices will be heard.

● To change the setting, hold down the MIDI/TRANPOSE switch and press the PIANO I switch.

LED off : LOCAL ON
LED on : LOCAL OFF

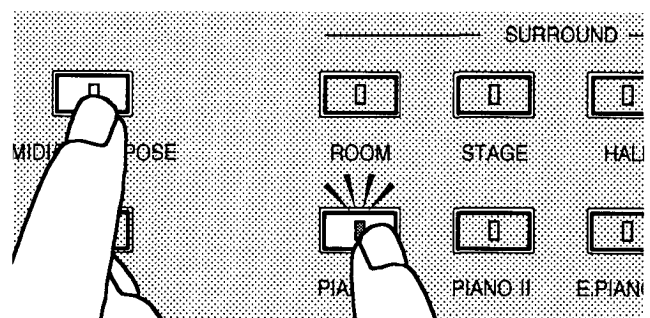

Note : When the power is turned on, the C - 56M defaults to LOCAL Mode ON.

3. Sending a PROGRAM CHANGE Request

A PROGRAM CHANGE request is a channel message that asks devices on that channel to change the sound that they are playing.

Note : The definition of “program” varies widely between MIDI devices. To verify terminology, consult the manual for the device being controlled.

- Pressing a VOICE SELECTOR switch transmits a Program Change message. The program number can be selected from the VOICE SELECTOR switches as shown below.

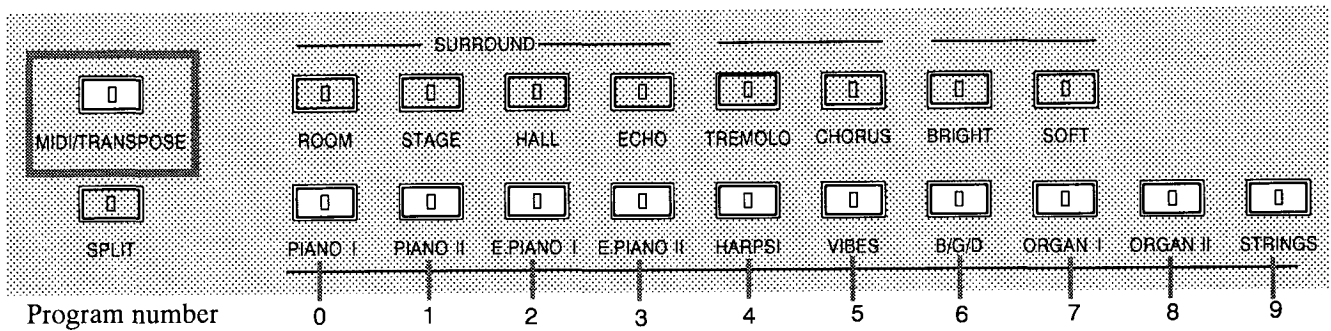

To transmit program numbers using the keyboard:

Most synthesizers offer more than 10 programs, so it becomes necessary to use the PROGRAM CHANGE zone of the keyboard to specify the new program number.

MIDI PROGRAM CHANGE keyboard zone

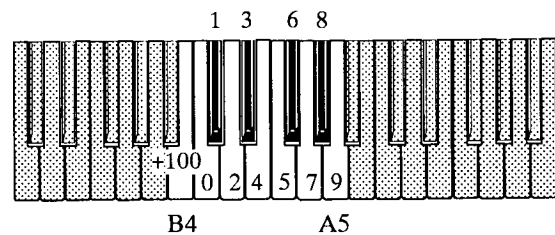

1. Hold down the MIDI/TRANPOSE switch.
2. If the number is greater than 99, press the “100” key (B4).

Note : The highest possible program number is 127.

3. Specify the two digits with the keys C5 through A5.

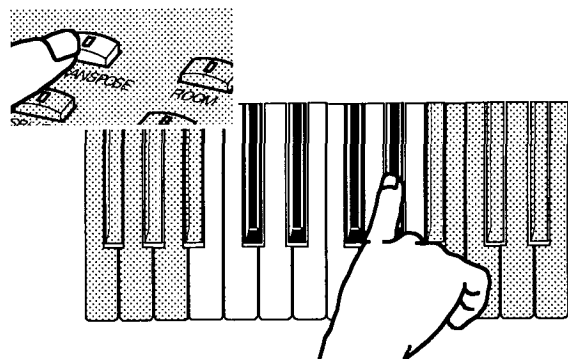

Examples:

Program #0	0	,	0
Program #1	0	,	1
Program #99	9	,	9
Program #100	+ 100	,	0
Program #101	+ 100	,	1
Program #127	+ 100	,	7

Note : The above procedure always transmits a PROGRAM CHANGE request – regardless of the PROGRAM CHANGE CANCEL setting. (See “Inhibiting PROGRAM CHANGE Requests” below.)

PROGRAM CHANGE Requests: LAYER Mode

- Changing to LAYER Mode or changing voices within that mode (See P.11) transmits a PROGRAM CHANGE request for only the second VOICE SELECTOR switch pressed.
- A PROGRAM CHANGE request from another MIDI device affects only the voice whose VOICE SELECTOR switch appears first on the panel (when reading from the left).

Note : Requests for program numbers outside the C - 56M's range (0 - 9) are ignored.

PROGRAM CHANGE Requests: SPLIT Mode

- Changing to SPLIT Mode or changing voices within that mode (See P.11) transmits a PROGRAM CHANGE request for only the upper zone of the keyboard. If the new voice combination leaves the upper zone of the keyboard with either old voice, no request is transmitted.
- A PROGRAM CHANGE request from another MIDI device affects only the voice for the upper zone of the keyboard.

Note : Requests for program numbers outside the C - 56M's range (0 - 9) are ignored.

Note : A request for the same program number as the left VOICE SELECTOR switch is not ignored, but instead returns the C - 56M to the SINGLE mode.

Note : When a VOICE SELECTOR switch is used to select the same voice already selected for the upper zone of the keyboard, the program number will not be transmitted.

Note : Using external program change messages to change the internal programs of the instrument will not change the program of the lower zone of the keyboard.

Inhibiting PROGRAM CHANGE Requests

When the PROGRAM CHANGE function is set to OFF, all incoming and outgoing PROGRAM CHANGE messages are ignored.

Note : This function does not affect selection of internal voices from the front panel VOICE SELECTOR switches.

To switch the function on and off, hold down the MIDI/TRANPOSE switch and press the PIANO II switch.

LED indicator off : PROGRAM CHANGE ON
 LED indicator on : PROGRAM CHANGE OFF

Note : When the power is turned on, the C - 56M always starts with the PROGRAM CHANGE function ON.

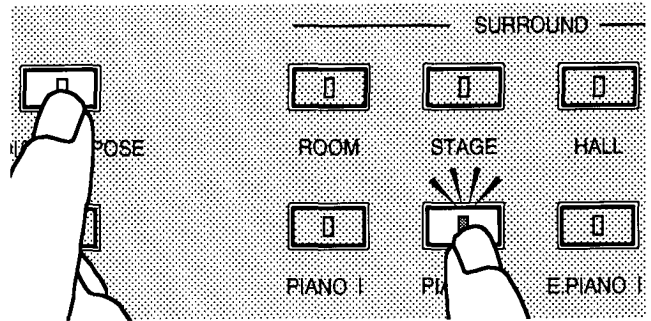

4. Inhibiting CONTROL CHANGE Requests

When the CONTROL CHANGE function is set to OFF, all incoming and outgoing CONTROL CHANGE messages are ignored, including those generated by the pedals.

To switch the function on or off, hold down the MIDI/TRANPOSE switch and press the E.PIANO I switch.

LED indicator off : CONTROL CHANGE ON
 LED indicator on : CONTROL CHANGE OFF

- Do not press down the pedal when switching this function ON and OFF.

Note : External control changes are effective for both voices in the LAYER mode and SPLIT mode regardless of the individual internal pedal settings. (Refer to the section "Using the Pedals with LAYER and SPLIT Mode".)

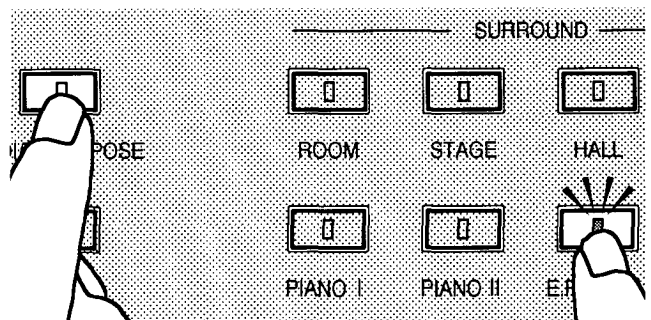

Note : When the power is turned on, the C - 56M always begins with the CONTROL CHANGE function ON.

5. Changing the MIDI Velocity Curve

Velocity curves determine how the volume and tone respond to velocity, the speed at which the keys are struck. Since the piano has a curve much different from other instruments, the C - 56M offers a choice of two curves for MIDI output.

Piano :

Curve duplicating that of an acoustic piano

Synthesizer :

Curve for other instruments or other MIDI sound sources, like synthesizers and tone modules.

Note : This setting affects other MIDI sound sources, not the C - 56M's internal sound source. The C - 56M always uses a preset velocity curve for its internal voices.

- To change the MIDI velocity curve, hold down the MIDI/TRANSDUCE switch and press the appropriate key at the right end of the keyboard:

G7 : Synthesizer-like velocity curve

A7 : Piano-like velocity curve

Note : When the power is turned on, the C - 56M is set to the Piano-like velocity curve.

Note : Velocity curve select functions only for an external sound device connected by MIDI. The sound of the C - 56M itself is subject to the setting of the Touch Control.

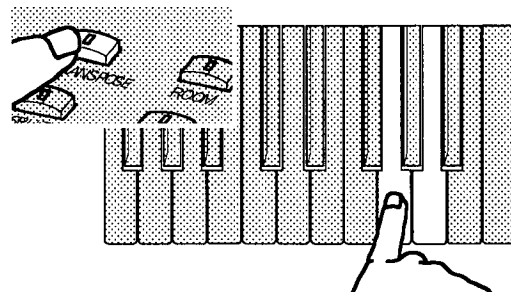
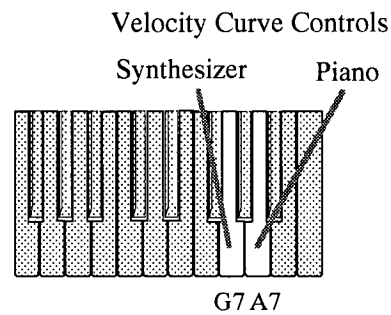

Synchronizing with external MIDI devices

The built-in recorder of the C-56M is capable of synchronizing with a drum machine, sequencer or other external MIDI devices. To use the C-56M as the master keyboard (controlling device) and the external device as the slave (controlled device), connect the MIDI OUT jack on the piano to the MIDI IN jack on the external device with a MIDI cable. (To change the MIDI clock setting on external devices, refer to the manual for each device.)

- To start and stop the synchronized play with external devices, use the START/STOP switch on the C-56M.
- The MIDI clock (timing data) sent from the C-56M will follow changes made with the TEMPO control slider.

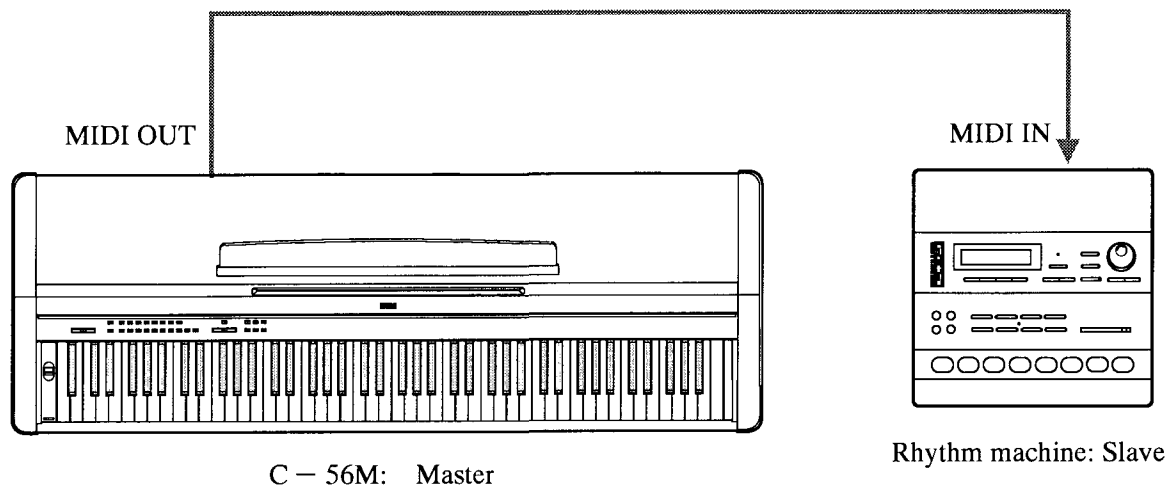

MIDI MULTI Function

The LAYER and SPLIT modes allow you to use two different voices at the same time. However, the MIDI MULTI function allows you to control more of the C - 56M's internal voices from external MIDI devices, such as sequencers and other MIDI recorders.

Note : The total number of notes sounding at any given time must not exceed the total number of sound sources available on the piano (thirty - two notes). In Layer mode, each key sounds two different voices, reducing the total number of available voices to sixteen.

Note : The piano gives higher precedence to the notes played first — that is, it ignores additional notes until the older ones are released. In contrast, most synthesizers drop older notes in favor of newer ones.

- The maximum number of received channels is 11, including a channel for the C - 56M's internal voice selected on the front panel. When the power is turned on, the C - 56M always begins with the following voice assignments for each channel:

CHANNEL	1	2	3	4	5	6	7	8	9	10	11
VOICE	Front panel Setting	PIANO I	PIANO II	E.PIANO I	E.PIANO II	HARPSI	VIBES	B/G/D	ORGAN I	ORGAN II	STRINGS

- The receive channel for the panel voice can be changed by re-selecting its MIDI channel (refer to "1. Changing the MIDI Transmit Channel"). When selecting a new MIDI channel, all other voices will be assigned to the rest of the MIDI channel numbers in increasing order.

When selecting Channel 3:

CHANNEL	3	4	5	6	7	8	9	10	11	12	13
VOICE	Front panel Setting	PIANO I	PIANO II	E.PIANO I	E.PIANO II	HARPSI	VIBES	B/G/D	ORGAN I	ORGAN II	STRINGS

When selecting Channel 14:

CHANNEL	14	15	16								
VOICE	Front panel Setting	PIANO I	PIANO II	/	/	/	/	/	/	/	/

- When Channel 16 is selected, for example, only the voice selected on the front panel will sound — other voices will be ignored.

When selecting Channel 16:

CHANNEL	16										
VOICE	Front panel Setting	/	/	/	/	/	/	/	/	/	/

Example of MIDI MULTI function

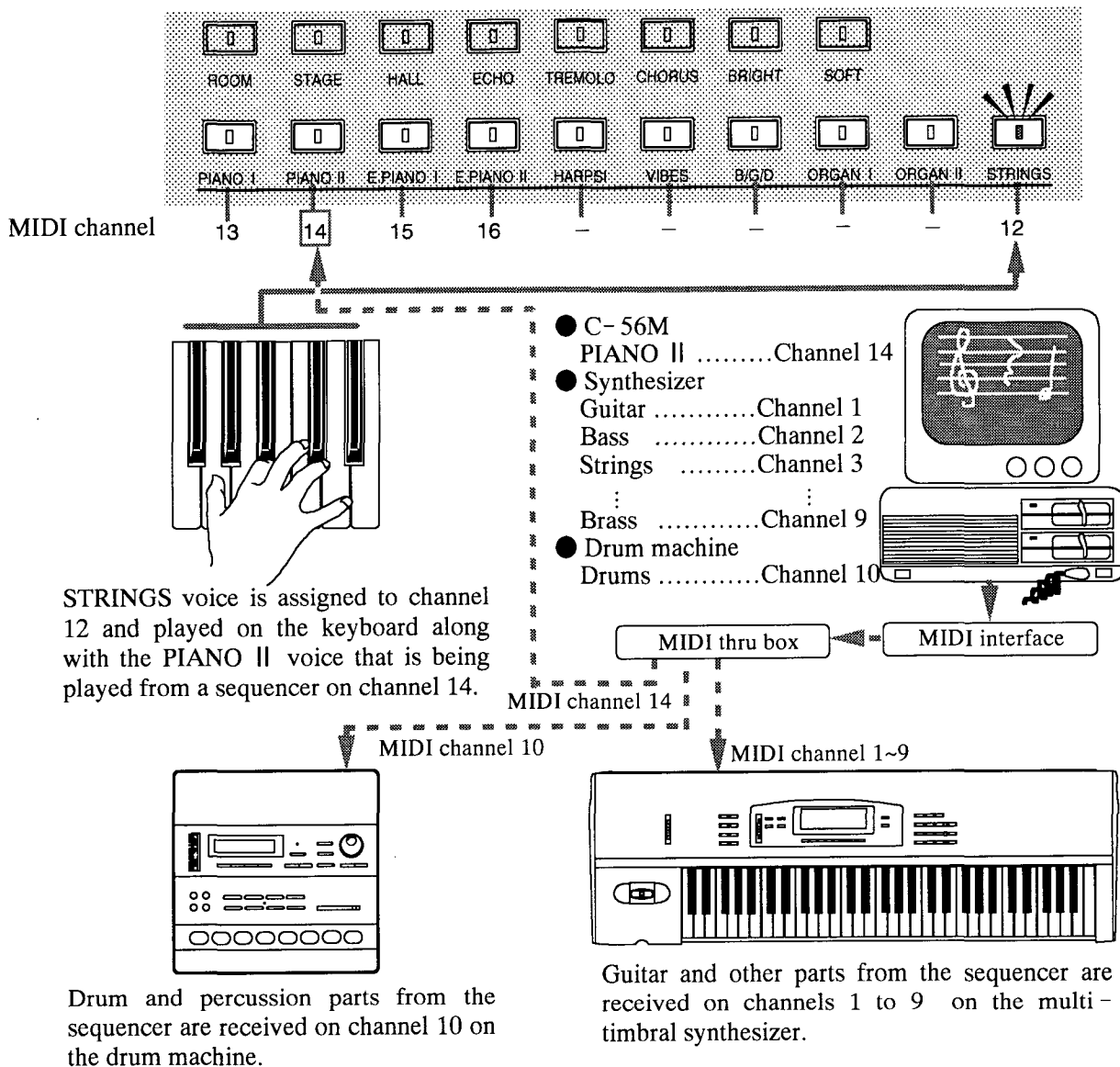

Connect the piano with the synthesizer, drum machine, sequencer or other MIDI devices that are capable of sending data on different MIDI channels.

As in the illustration, you can play the strings voice on the C-56M's keyboard along with the PIANO II voice that is being played by the sequencer. Additional parts can be played with drum voices on a drum machine and voices on a multi-timbral synthesizer by assigning different MIDI channels to different voices.

Select the appropriate MIDI channel numbers for each of the voices. In this example, the C-56M's keyboard is assigned to MIDI channel 12. MIDI channels 1 - 9 are assigned to guitar, bass, organ, brass and other voices on the synthesizer. Channel 10 is assigned for drums and percussion voices on the drum machine.

- The voice for each channel can be changed by sending program change data.
- Each channel operates independently not only for note and voice messages, but also for CONTROL CHANGE messages as well, such as pedal movements.
- The total number of notes sounding on the C-56M at any given time is the total number of sound sources available on the piano (thirty-two notes). Therefore, a maximum of thirty-two notes can be played on the C-56M (including the notes you play on the piano and the notes played from the external sequencer), regardless of the number of voices you select to play.

Using the MIDI Data Dump Function

The MIDI DATA DUMP function is used to copy data from the built-in recorder to a MIDI data filer, a device for storing MIDI data.

Note : The term “MIDI data filer” applies to both hardware and software devices.

A common data filer application is backing up data — in other words, copying the current recorder data to the filer so that you can always get the original data back after editing or deleting the data in the recorder. For further details, consult the manuals included with your synthesizer, drum machine, or other MIDI equipment.

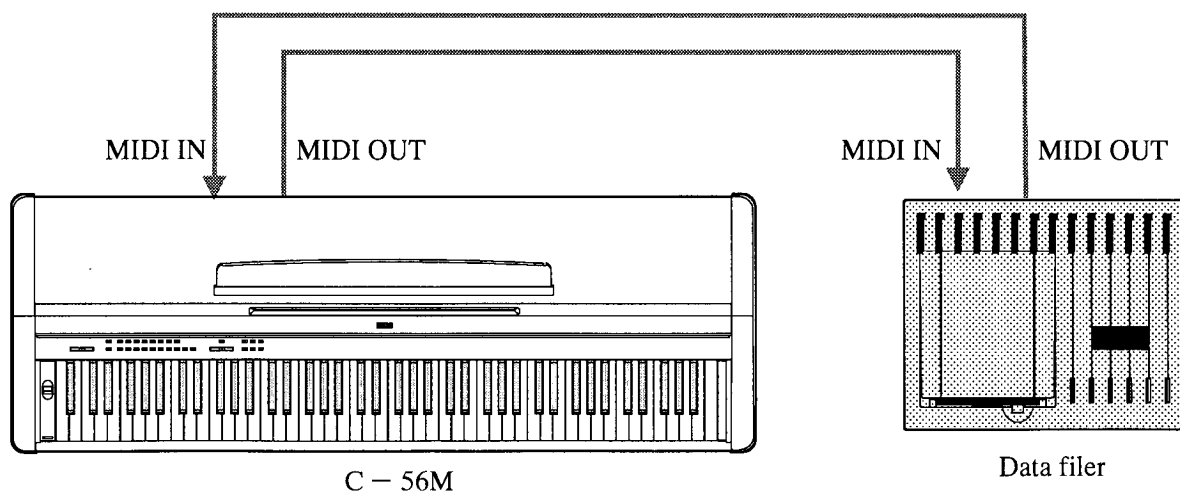

Saving Data to the Data Filer

Use the MIDI/TRANPOSE switch on the front panel of the C-56M and the STRINGS voice selector switch to execute the data dump.

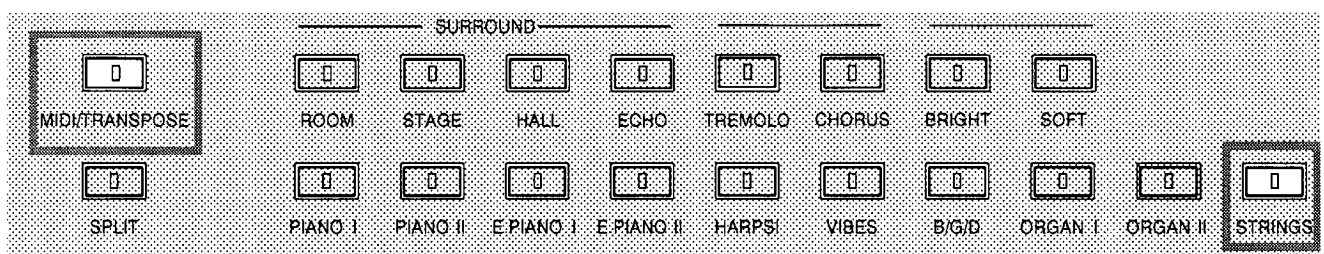

1. Use standard MIDI cables to connect the piano and a data filer as shown in the illustration on P.46.
2. Set the data filer to receive data.

Note : Consult the manual included with the data filer for the necessary procedures.

3. Hold down the MIDI/TRANSPOSE switch and press the STRINGS switch to start transmission.
4. Wait for the data filer to indicate the end of the transmission.

Note : The time required depends not only on the amount of data, but also on the data filer. There is considerable variation between different data filer models. Refer to the manual included with the data filer for further details.

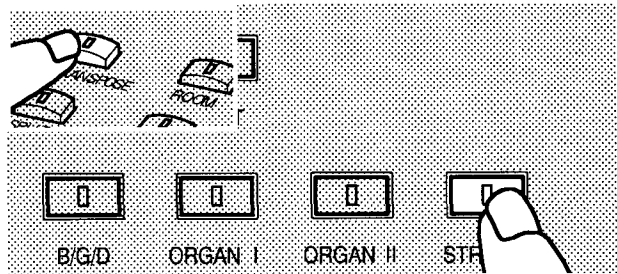

Note : Never interrupt either the piano or the data filer while they are working, since such interruptions can cause errors in data transmission.

Loading Data from the Data Filer

1. Use standard MIDI cables to connect the piano and a data filer as shown in the accompanying Figure.
2. Turn on the power of both units.
3. Set up the data filer to transmit piano data previously stored.

Note : As there is considerable variation between data filers, consult the manual included with the data filer for additional procedures.

4. Wait for the data filer to indicate the end of the transmission (Never interrupt either the piano or the data filer while they are working, since such interruptions can cause errors in data transmission).

Note : The piano keyboard and panel will remain in-operative until the transmission is complete.

Note : The data which was stored once in the data filer cannot be bounced or merged after loading it again to the recorder of the C-56M. If you intend to use the merge function, be careful to perform all merging operations BEFORE storing data in the data filer.

Note : Changes made in the pedal settings cannot be stored in the data filer (Refer to the section, "Using the Pedals with LAYER and SPLIT Mode").

MIDI Implementation

1. TRANSMITTED DATA

1-1 CHANNEL MESSAGES

Status	Second	Third	Description	ENA
1000 nnnn	0kkk kkkk	0100 0000	Note Off kkk kkkk=15-113	A
1001 nnnn	0kkk kkkk	0vvv vvvv	Note On kkk kkkk=15-113 vvv vvvv=1-127	A
1011 nnnn	0100 0000	0000 0000	Damper Off(Damper Pedal)	C
1011 nnnn	0100 0000	0111 1111	Damper On(Damper Pedal)	C
1011 nnnn	0100 0010	0000 0000	Sostenuto Off(Sostenuto Pedal)	C
1011 nnnn	0100 0010	0111 1111	Sostenuto On(Sostenuto Pedal)	C
1011 nnnn	0100 0011	0000 0000	Soft Off(Soft Pedal)	C
1011 nnnn	0100 0011	0111 1111	Soft On(Soft Pedal)	C
1100 nnnn	0ppp pppp	-----	Program Change ppp pppp=0-127	P*

nnnn : MIDI Channel No.(0-15)Usually Global Channel.

ENA=A : Always Enabled

C : Enabled when Control Filter is ENA

P : Enabled when Program Filter is ENA

*Program change is transmitted though keyboard, regardless of ENABLE/CANCEL.

1-2 SYSTEM REALTIME MESSAGES

Status	Description
1111 1000	Timing Clock *2
1111 1010	Start *2
1111 1011	Continue *2
1111 1100	Stop *2
1111 1110	Active Sensing

*2 : Transmits when Recorder is playing or Recording

2. RECOGNIZED RECEIVE DATA

2-1 CHANNEL MESSAGES

Status	Second	Third	Description	ENA
1000 nnnn	0kkk kkkk	0xxx xxxx	Note Off	A
1001 nnnn	0kkk kkkk	0000 0000	Note Off	A
1001 nnnn	0kkk kkkk	0vvv vvvv	Note On vvv vvvv=1-127	A
1011 nnnn	0000 0111	0vvv vvvv	Volume	C
1011 nnnn	0100 0000	00xx xxxx	Damper Off	C
1011 nnnn	0100 0000	01xx xxxx	Damper On	C
1011 nnnn	0100 0010	00xx xxxx	Sostenuto Off	C
1011 nnnn	0100 0010	01xx xxxx	Sostenuto On	C
1011 nnnn	0100 0011	00xx xxxx	Soft Off	C
1011 nnnn	0100 0011	01xx xxxx	Soft On	C
1011 nnnn	0111 1010	0000 0000	Local Control Off	A
1011 nnnn	0111 1010	0111 1111	Local Control On	A
1011 nnnn	0111 1011	0000 0000	All Notes Off	A
1011 nnnn	0111 110x	0000 0000	(All Notes Off)	A
1011 nnnn	0111 1110	000m mmmm	(All Notes Off) m mmmm=0-16	A
1011 nnnn	0111 1111	0000 0000	(All Notes Off)	A
1011 nnnn	0ppp pppp	-----	Program Change	A

x : Random

ENA Same as TRANSMITTED DATA

2-2 SYSTEM REALTIME MESSAGES

Status	Description
1111 1110	Active Sensing

3. MIDI EXCLUSIVE FORMAT(R:Receive, T:Transmit)

3-1 SYSTEM EXCLUSIVE MESSAGE

1st Byte = 1111 0000(F0)	: Exclusive Status	EX.Header
2nd Byte = 0100 0010(42)	: KORG ID	
3rd Byte = 0011 nnnn(3n)	: Format ID n : Global ch.	
4th Byte = 0010 1011(2F)	: C-58M ID	
5th Byte = 0100 1000(48)	: Function=All Sequencer Data Dump	
6th Byte = 0odd dddd(dd)	: Data	
.....	
LastByte = 1111 0111(F7)	: End of Exclusive EOX	

ALL SEQUENCER DATA DUMP R, T

Byte	Description
F0, 42, 3n, 2F	EXCLUSIVE HEADER
0100 1000	ALL SEQUENCER DATA DUMP 48H
00mm iiii	channel 0 status (See Note 1)
0bbb jjjj	}
0kkk kkkk	
0ppp pppp	
0qqq qqqq	
.....
00mm iiii	channel 15 status (See Note 1)
0bbb jjjj	}
0kkk kkkk	
0ppp pppp	
0qqq qqqq	
.....
0rrr rrrr	Track 1 Data size(=0hmm mmmm mrrr rrrr)
0mmm mmmm	}
0000 000h	
0ddd dddd	Track 1 Data
.....
0rrr rrrr	Track 2 Data size(0hmm mmmm mrrr rrrr)
0mmm mmmm	}
0000 000h	
0ddd dddd	Track 2 Data
.....
0000 cccc	Next Bounce Channel
1111 0111	END OF EXCLUSIVE

Note 1)

mm : 00=Single, 01=Split, 10=Layer, 11=Inhibit

iiii : Instrument No. (Single, Split Upper, Layer1)

jjjj : Instrument No. (Split Lower, Layer2)

bbb : Volume balance

kkkkkk : Split point

pppppp : Upper Split Octave Value

qqqqqq : Lower Split Octave Value

ch0: Track1, ch1: Track2, ch2--ch15: Bounce channel (Track2)

C-56M MIDI Implementation Chart

Function		Transmitted	Recognized	Remarks
Basic Channel	Default Changed	1 1 - 16	1 - 16	
Mode	Default Messages Altered	× × *****	3 ×	
Note Number:	True voice	15 - 113 *****	0 - 127 21 - 108	
Velocity	Note ON Note OFF	1 - 127 ×	1 - 127 ×	
After Touch	Key's Channel's	× ×	× ×	
Pitch Bender		×	×	
Control Change	7 64 66 67	× ○ ○ ○	○ ○ ○ ○	Volume *1 Damper Pedal *2 Sostenuto Pedal *2 Soft Pedal *2
Prog Change:	True #	0 - 127 *****	0 - 9 0 - 9	*3
System Exclusive		○	○	Device Inquiry Sequence Data Dump
System Common	:Song Pos :Song Sel :Tune	× × ×	× × ×	
System Real Time	:Clock :Commands	× ×	× ×	
Aux Messages	:Local ON/OFF :All Notes OFF :Active Sense :Reset	× × ○ ×	○ ○ 123 - 127 ○ ×	

Notes *1 Receive if CONTROL CHANGE set to ENABLE.

*2 Transmit/receive if CONTROL CHANGE set to ENABLE.

*3 Transmit/receive if PROGRAM CHANGE set to ENABLE.

Program change is transmitted through keyboard, regardless of ENABLE/CANCEL.

Mode 1:OMNI ON, POLY
Mode 3:OMNI OFF, POLY

Mode 2:OMNI ON, MONO
Mode 4:OMNI OFF, MONO

○ :ON
× :OFF

MIDI/TRANSPOSE Switch

The MIDI/TRANSPOSE switch is used to set various other functions besides the transpose function and the MIDI mode.

Press the corresponding switches while holding down the MIDI/TRANSPOSE switch.

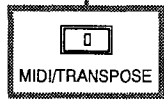

SPLIT
Split Point
(page 13)

Setting Touch Control
(page 17)

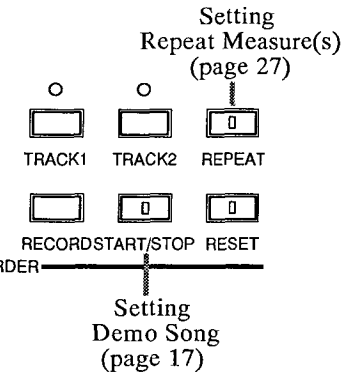
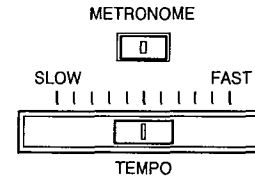
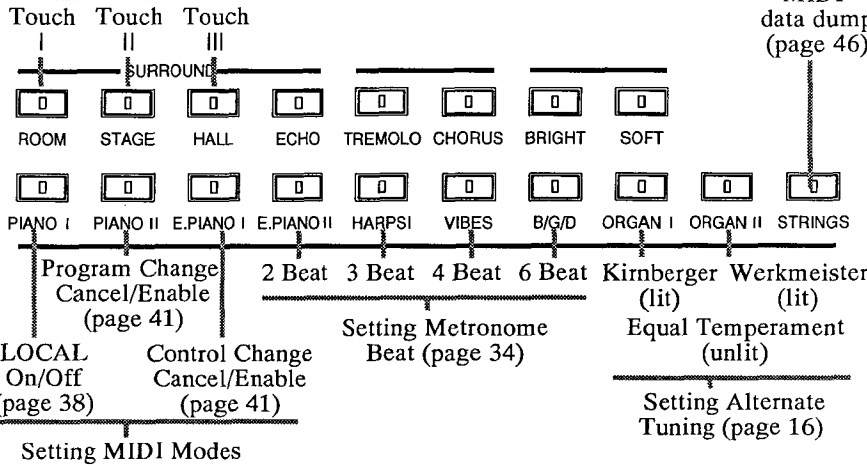

Setting the lower range octave in Split Mode (page 12)
Octave Down A0 Octave Up A#0

Setting the upper range octave in Split Mode (page 12)
Octave Down B7 Octave Up C8

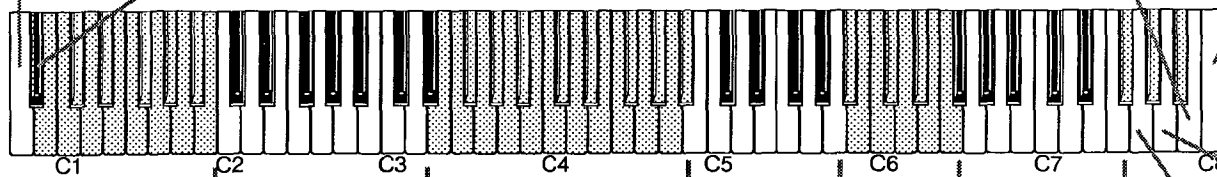

Setting MIDI channel
C 2~D#3 (page 38)

Sending MIDI
program changes
B 4~A 5 (page 39)

Setting
Transpose Function
F#6~F 7 (page 19)

Synthesizer G7 Piano A7
Setting Velocity
Curve (page 42)

Setting Pedals to one or both timbres
in Layer and Split modes. (page 15)
Disable one timbre/ Disable the
other timbre/ Both Enable

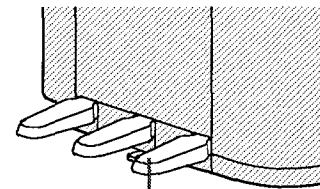

Damper Pedal

Trouble Shooting

If the following problems develop during normal operation of the C - 56M, follow the suggestions below and check the unit to identify and correct the problem. If the C - 56M still does not function properly, consult your dealer or a KORG service center.

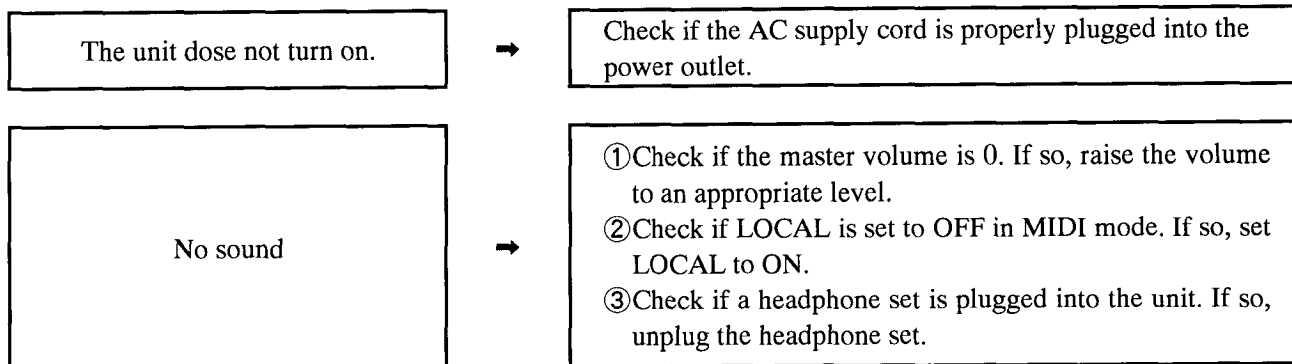

Specifications

■ Keyboard	:	88 keys (A0 – C8)
■ Voices	:	Piano 1, Piano 2, Electric Piano 1, Electric Piano 2, Harpsichord, Vibes, Bass/Guitar/Drums, Organ 1, Organ 2, Strings
■ Polyphony	:	32 Note
■ Effects	:	Advanced Surround (Room, Stage, Hall, Echo), Tremolo, Chorus, Bright, Soft
■ Recorder	:	Maximum 3,400 notes, Tempo, Metronome, Track1, Track2, Repeat, Record, Start/Stop, Reset (with Bounce Function)
■ Keyboard Mode	:	Single, Layer, Split (MIDI Multi)
■ Controls	:	Volume, Power, Key Transpose, Pitch, Touch, Traditional Classical Music Tuning
■ Pedal controls	:	Damper, Soft, Sostenuto
■ Connections	:	HEADPHONES, AUX IN(L, R), AUX OUT(L, R), MIDI IN • OUT • THRU
■ Main Amplifier	:	(40W+10W) × 2
■ Speakers	:	6 in. × 2, 3 in. × 2, 2 in. × 2 (16 cm × 2, 8 cm × 2, 5 cm × 2)
■ Power Supply	:	AC, Local Voltage
■ Power Consumption	:	110 W
■ Color and Grain	:	Black Walnut
■ Dimensions	:	54 in. (W) × 19 in. (D) × 33 in. (H) (1382 × 491.5 × 844 mm)
■ Weight	:	121 lbs. (54.8 kg)
■ Standard Accessories	:	Music Stand, Key Cover

Note : Design and specifications are subject to change without prior notice.

NOTICE

KORG products are manufactured under strict specifications and voltages required by each country. These products are warranted by the KORG distributor only in each country. Any KORG product not sold with a warranty card or carrying a serial number disqualifies the product sold from the manufacturer's/distributor's warranty and liability. This requirement is for your own protection and safety.

KORG

KORG INC.

15-12, Shimotakaido 1-chome, Suginami-ku, Tokyo, Japan.