

R3 SYNTHESIZER/ VOCODER



Effect guide

KORG

Table of contents

Overview..... 1

About the effect inputs and outputs 1

About the delay time..... 1

- TimeRati 1
- Delay time for the insert effects 1

Controlling the effect parameters 2

Synchronizing the LFO 1/2 rate or the delay time of the delay effect to the ar- peggiator tempo 2

How “SYNC NOTE” and “RESOLUTION” settings correspond to note values 2

Effect parameters 3

1. S.Comp (Stereo Compressor)	3
2. S.Limit (Stereo Limiter)	4
3. S.Gate (Stereo Gate)	4
4. S.Filter (Stereo Filter)	5
5. S.Wah (Stereo Wah)	6
6. S.2BndEQ (Stereo 2Band EQ) S.4BndEQ (Stereo 4Band EQ)	7
7. Distort (Distortion)	8
8. Cabi Sim (Cabinet Simulator)	9
9. Tube Sim (Tube PreAmp Simulator) S.TubSim (Stereo Tube PreAmp Simulator)	9
10. S.Dcmtr (Stereo Decimator)	10
11. Reverb.....	11
12. EarlyRef (Early Reflections)	12
13. LCR Dly (L/C/R Delay).....	13
14. S.Delay (Stereo Delay).....	14
15. AtPanDly (Auto Panning Delay)	14
16. S.APnDly (Stereo Auto Panning Delay).....	15
17. ModDelay (Modulation Delay)	16
18. S.ModDly (Stereo Modulation Delay)	17
19. TapeEcho	17
20. S.Chorus (Stereo Chorus)	18
21. Ensemble	18
22. S.Flanger (Stereo Flanger/Comb Filter).....	19
23. S.Phaser (Stereo Phaser)	20
24. S.Tremol (Stereo Tremolo)	21
25. S.RingMd (Stereo Ring Modulator).....	21
26. PitchSft (Pitch Shifter) S.PtcShft (Stereo Pitch Shifter)	22

27. GrainSft (Grain Shifter) S.GrnSft (Stereo Grain Shifter)	23
28. S.Vibart (Stereo Vibrato)	24
29. W.RotSpk (Rotary Speaker) RotrySpk (Rotary Speaker)	25
30. W.TalkMd (Talking Modulation) Talk Mod (Talking Modulation)	26

Overview

The effect section of the **R3** consists of a two-band EQ and two insert effects per timbre, and one master effect for the entire program. You can use the EQ and insert effects to create the sound of each timbre, and use the master effect to add overall spatial processing.

For each of the insert effects and master effect, you can choose one of thirty types of full-digital effect. The types of effects are grouped in the following categories.

01–10	Filter and dynamics effects such as EQ and compressor
11–19	Reverb, early reflection, and delay
20–30	Pitch and phase modulation effects such as chorus and phaser, rotary speaker, and pitch shifter

About the effect inputs and outputs

The insert effects and master effects are stereo-in/stereo-out. The Dry signal (the direct, unprocessed sound) of the “Dry/Wet” balance will simply pass through the stereo input as a stereo output. The way in which the Wet signal (the sound processed by the effect) is output will depend on the type of effect, and the possible configurations are shown below.



In the block diagram given for each effect in the pages that follow, the input/output configuration is listed in the upper left of the diagram.

In order to obtain the best audio quality, use 12. Amp page “Level,” 7. Mixer page “OSC1 Lvl,” “OSC2 Lvl,” and “Noise Lvl” to adjust the input level to the insert effect and master effect, and set the “Trim” of each effect to the maximum level that does not cause clipping. Then use the “Dry/Wet” and “Output Level” of each effect to adjust the output level of the effect.

Some effect types do not have a “Trim” or “Output Level” parameter.

There is no input level meter that indicates the input level to the effect. If the input level is insufficient, the S/N ratio will be degraded. If the input level is excessive, clipping may occur.

About the delay time

TimeRatio

For delay effects, the actual delay time is determined by multiplying the delay time with the “TimRatio (TimeRatio).” Here are some examples.

- “BPM Sync”: Off, “L Delay”: 800 ms, “R Delay”: 400 ms, “TimRatio”: 50% settings will produce an actual delay of 400 ms for the L-channel and 200 ms for the R-channel.
- “BPM Sync”: On, “L Delay”: ♩ 1/4, “R Delay”: ♪ 1/8, “TimRatio”: 50% settings will produce an actual delay of an 8th note for the L-channel and a 16th note for the R-channel.

Delay time for the insert effects

Broadly speaking, there are two types of effect for which you can specify a delay time.

- Delay effects
- Modulation effects such as chorus that internally use a fixed delay time

If you use such an effect in the two insert effects, the delay time of the effects can be set for a maximum of 1 second for each timbre.

Here are some examples.

- Insert effect 1 uses S.Delay (Stereo Delay,) and insert effect 2 uses S.APnDly (St.Auto Panning Delay.) 500 ms of delay time is assigned to each effect.

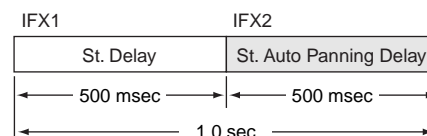

- Insert effect 1 uses S.Chorus (St.Chorus,) and insert effect 2 uses S.Delay (Stereo Delay.) 160 ms of delay time is assigned to S.Chorus, and 840 ms of delay time is assigned to St.Delay.

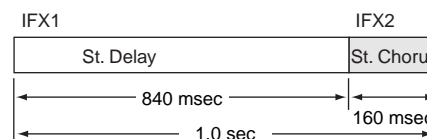

Controlling the effect parameters

On the **R3** you can assign one parameter each from insert effects 1 and 2 and the master effect (a total of three parameters) to knobs [1-4] and control these parameters while you perform.

Before you assign a parameter to a knob, you must first select one parameter from each effect and specify this parameter as the “Fx Knob” in the effect parameter settings (R3 owner’s manual p.49). After you’ve made this setting, you can use the Shift function Knob Assign to select IFx1Knob or IFx2Knob etc., and use the knob to control the parameter that you assigned in “Fx Knob” (R3 owner’s manual p.80).

Synchronizing the LFO 1/2 rate or the delay time of the delay effect to the arpeggiator tempo

You can synchronize the LFO 1/2 rate or the delay time of the delay effect to the arpeggiator tempo. (When “BPM SYNC”=ON)

Example 1. LFO1

16. LFO1 page “BPM Sync” (knob [3]): ON
 16. LFO1 page LFO1 “SyncNote” (knob [4]): 1/4
 In this case, one LFO cycle will occupy the same time as one quarter note.

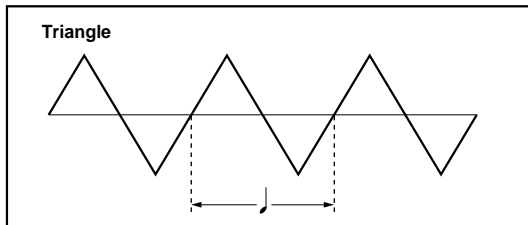

Example 2. Delay time

29. Ins FX1 page “Type” (knob [1]): S.Delay
 29. Ins FX1 page “Parameter” (knob [3]): BPM Sync, “Vaue” (knob [4]): On
 29. Ins FX1 page “Parameter” (knob [3]): L Delay, “Vaue” (knob [4]): 1/8
 29. Ins FX1 page “Parameter” (knob [3]): R Delay, “Vaue” (knob [4]): 1/8

In this case, the delay time will be set to a time interval of an eighth note, and will alternate between left and right channels.

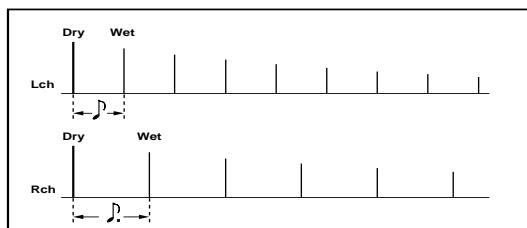

How “SYNC NOTE” and “RESOLUTION” settings correspond to note values

The following table shows how LFO or delay effect “SyncNote” settings and 33. Arpeg-B page “Resolutn” settings correspond to note values.

The parameters will function according to the tempo specified by [TEMPO] knob and the note value corresponding to its setting.

Note	LFO, Delay: “SyncNote”	Arpeggiator: “Resolutn”
	1/64	
	1/32	1/32
	1/24	1/24
	1/16	1/16
	1/12	1/12
	1/8	1/8
	1/6	1/6
	3/16	
	1/4	1/4
	1/3	
	3/8	
	1/2	1/2
	2/3	
	3/4	
	1/1	1/1

Effect parameters

- **[parameter name] only MFX:** This parameter will be displayed and can be set only when the effect is used by a master effect.
- **[parameter name] only IFX:** This parameter will be displayed and can be set only when the effect is used by an insert effect.
- **[effect name] double size:** This effect can be selected only for insert effect 1. If you select this type of effect, you can't use insert effect 2.
- **[parameter name] **: This indicates a parameter you can select for "Fx Knob." You can assign the parameter to a front panel knob and edit it while you perform.
- **Common parameters:**
 Dry/Wet [Dry, 99:1...1:99, Wet]
 Fx Knob [available selections depend on the type of effect]: Choose the effect parameter that you want to assign to a front panel knob.

Attack  [000.1...500.0ms]
 Sets the attack level.

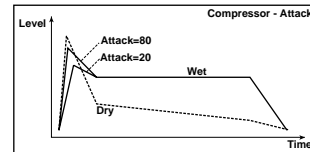

OutLevel (Output Level) [000...127]
 This parameter controls the output level.

1. S.Comp (Stereo Compressor)

This effect compresses the input signal to regulate the level and give a "punchy" effect. This is useful when applied to sounds that have a strong attack.

If using this for the master effect, you can link the left and right channels or make them operate independently.

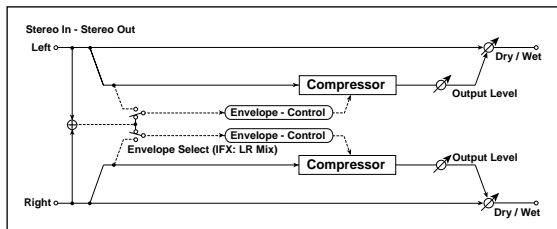

Env Sel (Envelope Select) only MFX [LR Mix, LR Indv.]

When L/R Mix is selected for this parameter, the left and right channels are linked to control the Limiter using the mixed signal.

With L/R individually, the left and right channels control the Limiter individually.

 When using this effect type for an insert effect, this parameter is fixed at LR Mix.

Sens (Sensitivity)  [001...127]

The "Sens" parameter sets the sensitivity of the compressor. If this parameter is set to a higher value, lower level sounds will be boosted. With a higher Sensitivity, the overall volume level is higher. To adjust the final volume level, use the "Output Level" parameter.

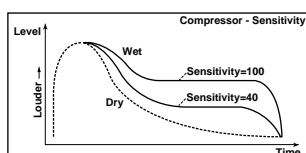

2. S.Limit (Stereo Limiter)

The Limiter regulates the input signal level. It is similar to the Compressor, except that the Limiter compresses only signals that exceed the specified level to lower unnecessary peak signals. If using this for the master effect, you can link the left and right channels or make them operate independently.

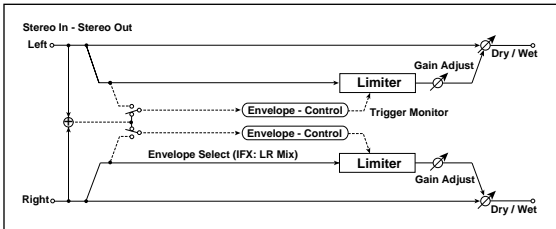

Env Sel (Envelope Select) only MFX [LR Mix, LR Indv.]
 p.3 “1. S.Comp (Stereo Compressor)”

Ratio [1.0:1...50.0:1...Inf:1]
 Sets the signal compression ratio.

Threshld (Threshold) [-40...+00dB]
 Sets the level above which the compressor is applied. Compression is applied only when the signal level exceeds the “Threshld” value.

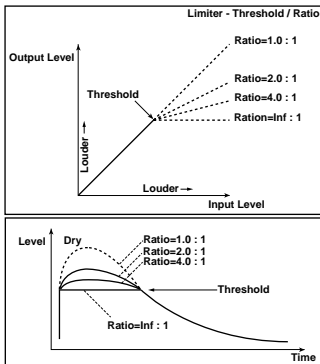

Attack [000.1...500.0ms]
 Sets the attack time. A higher attack time will cause the compression to be applied more slowly.

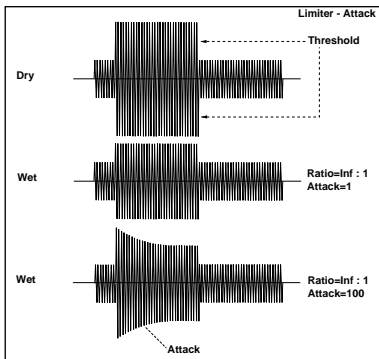

GainAjust (Gain Adjust) [-Inf...+24dB]
 Sets the output gain. Adjust the output level using the “GainAjust” parameter, since compression causes the entire level to be reduced.

3. S.Gate (Stereo Gate)

This effect mutes the input signal if its level is lower than the specified level.

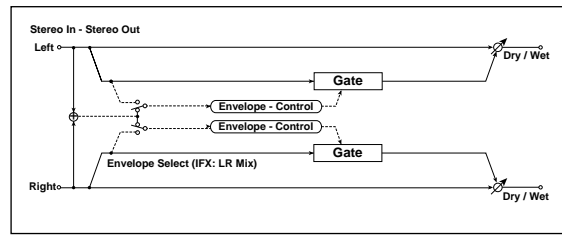

Env Sel (Envelope Select) only MFX [LR Mix, LR Indv.]
 p.3 “1. S.Comp (Stereo Compressor)”

Threshld (Threshold) [000...127]
 Sets the level to which the Gate is applied.

Attack [000.1...500.0ms]
 Sets the Gate attack time.

Release [0000.3...1500.0ms]
 Sets the Gate release time.

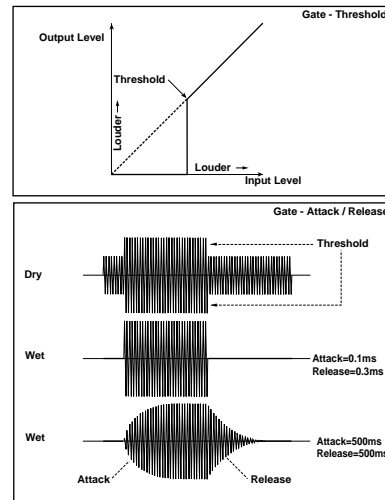

GainAjust (Gain Adjust) [-Inf...+24dB]
 Sets the output gain.

4. S.Filter (Stereo Filter)

This is a stereo filter.

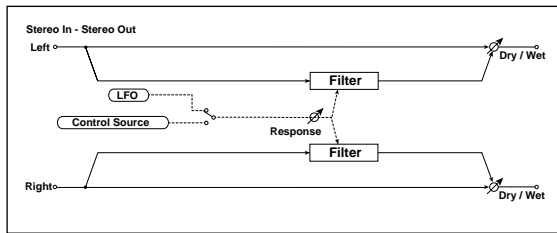

Filter (Filter Type) [LPF24, LPF18, LPF12, HPF12, BPF12]

Selects the filter type.

R3 owner's manual p.32 "FiltBall1"

Cutoff [000...127]

Sets the filter cutoff frequency.

R3 owner's manual p.32 "Cutoff1"

Resonanc (Resonance) [000...127]

Sets the filter resonance amount.

R3 owner's manual p.32 "Resol1"

Trim [000...127]

Sets the input level.

Mod Src (Modulation Source) [LFO, Ctrl]

Selects the modulation source that will control the cutoff frequency. If you set this to LFO, the internal LFO will modulate the cutoff frequency. If you set this to Ctrl, the control source selected by "Ctrl Src" will control the cutoff frequency.

Mod Int (Modulation Intensity) [-63...+63]

Adjusts the depth of modulation applied by the modulation source ("Mod Src").

Response (Modulation Response) [000...127]

Adjusts the response of the modulation effect.

A setting of 0 produces slow response.

LFO Sync (LFO BPM Sync) [Off, On]

Specifies whether the internal LFO cycle will synchronize to the tempo set by the [TEMPO] knob or by MIDI clock. This parameter will be displayed and can be set if "Mod Int" is LFO.

If this is Off, the LFO will operate at the cycle specified by "LFO Freq."

If this is On, the LFO will synchronize to the tempo or MIDI clock.

note In the 42. MIDI page "Clock" setting is Internal, the LFO will synchronize to the tempo specified by the [TEMPO] knob. If the setting is External, the LFO will synchronize to the MIDI clock received from an external MIDI device.

LFO Freq (LFO Frequency) [0.01...100.0Hz]

Sets the LFO speed. This parameter will be displayed and can be set if "Mod Src" is LFO and "BPM Sync" is Off.

Increasing this value will result in a faster frequency.

If this parameter is assigned to "Fx Knob," the assignment will change to SyncNote if you turn "BPM Sync" on. In the same way, setting "Mod Src" to Ctrl will cancel this (assign it to Off), and the knob will have no effect.

SyncNote (LFO SyncNote) [8/1...1/64]

Sets the internal LFO frequency as a proportion of the tempo set by the [TEMPO] knob if "Mod Src" is LFO and "BPM Sync" is On. The length of the specified value (note value) relative to the tempo will be one cycle of the LFO. For example if this is $\frac{1}{4}$, one cycle will occupy one quarter note.

If this parameter is assigned for "Fx Knob," turning "BPM Sync" On will switch the assignment to Sync Note. In the same way, setting "Mod Src" to Ctrl will cancel this (assign it to Off), and the knob will have no effect.

LFO Wave (LFO Waveform)

[Saw, Square, Triangle, Sine, S&H]

Selects the internal LFO waveform if "Mod Src" is LFO.

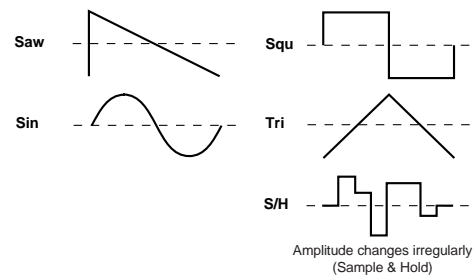

LFOShape [-63...+63]

Adjusts the shape of the internal LFO waveform if "Mod Src" is LFO.

Key Sync (LFO KeySync) [Off, Timbre]

Specifies how the LFO will be reset at note-on if "Mod Src" is LFO.

With Off, the LFO phase will not be reset when note-on occurs.

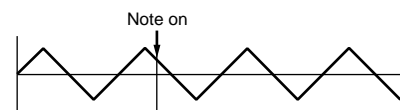

With Timbre, the first note-on from a condition of no keys being pressed will reset the LFO to the phase specified by "IniPhase," and modulation will be applied at that phase even if subsequent note-ons occur.

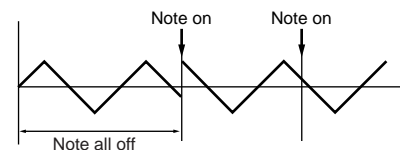

IniPhase (LFO Init Phase) [000...180°]

Specifies the starting position of the waveform if "Key Sync" is Timbre.

With a setting of 0°, the waveform will start from its beginning at note-on.

With a setting of 180°, the waveform will start from the mid-point of its cycle at note-on.

Ctrl Src (Control Source) [Off, Velocity...MIDI3]

Selects the control source if “Mod Src” is Ctrl. The filter will be controlled by the selected source.

Source	Explanation
Off	Not used
Velocity	Velocity
P.Bend	[PITCH] wheel
M.Wheel	[MOD] wheel
F.Pedal	Foot pedal
Damper	Damper pedal
MIDI1	Source specified by “MIDI1” in 45. PatchSrc page
MIDI2	Source specified by “MIDI2” in 45. PatchSrc page
MIDI3	Source specified by “MIDI3” in 45. PatchSrc page

5. S.Wah (Stereo Wah)

This stereo wah effect allows you to create sounds from vintage wah pedal simulation to auto-wah simulation, and much broader range settings.

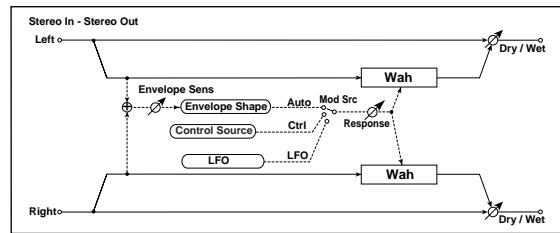

Wah Type [Y-CRY, RM-A, RM-B, J-CRY, VOX, M-VOX]

Selects the wah type.

If “Mod Src” is Auto or Ctrl (other than PitchBend), settings of “Wah Freq”=0, “Resonanc (Resonance)”=0, and “Mod Int”=+63 will produce the response of a modeled wah.

If “Mod Src” is LFO or Ctrl (PitchBend), settings of “Wah Freq”=32, “Resonanc (Resonance)”=0, and “Mod Int”=+45 will produce the response of a modeled wah.

Wah Freq (Frequency) [-63...+63]

Sets the wah center frequency.

Resonanc (Resonance) [-63...+63]

Sets the resonance amount.

Mod Src (Modulation Source) [Auto, LFO, Ctrl]

Selects the source that will control the center frequency of the wah.

When “Mod Src” is set to Auto will select an auto-wah that sweeps according to envelope changes in the input signal level. Auto-wah is frequently used for funk guitar parts and clav sounds.

When “Mod Src” is set to LFO, the effect uses internal LFO to sweep in cycle.

When “Mod Src” is set to Ctrl, you can control the filter directly via the modulation source in the same way as a wah pedal.

Mod Int (Modulation Intensity) [-63...+63]

Adjusts the depth of the modulation produced by the modulation source (“Mod Src”).

Response (Modulation Response) [000...127]

Adjusts the response of the modulation effect. A setting of 0 produces the slowest response.

Env Sens (Envelope Sensitivity) [000...127]

When “Mod Src” is set to Auto, sets the sensitivity of auto-wah. Increase the value if the input signal is too low to sweep. Reduce the value if the input signal is so high that the filter is stopped temporarily.

EnvShape (Envelope Shape) [-63...+63]

When “Mod Src” is set to Auto, this parameter determines the sweep curve for auto-wah.

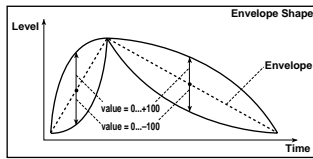

BPM Sync (LFO BPM Sync) [Off, On]

Specifies whether the internal LFO cycle will synchronize to the tempo set by the [TEMPO] knob or MIDI clock if “Mod Src” is LFO.

p.5 “LFO Sync (LFO BPM Sync)”

LFO Freq (LFO Frequency) [0.01...100Hz]

Sets the LFO speed if “Mod Src” is LFO and “BPM Sync” is Off.

p.5 “LFO Freq (LFO Frequency)”

SyncNote (LFO SyncNote) [8/1...1/64]

Sets the LFO frequency as a proportion of the tempo set by the [TEMPO] knob if “Mod Src” is LFO and “BPM Sync” is On.

p.5 “SyncNote (LFO SyncNote)”

LFO Wave (LFO Waveform) [Saw, Square, Triangle, Sine, S&H]

Selects the LFO waveform if “Mod Src” is LFO.

p.5 “LFO Wave (LFO Waveform)”

LFOShape [-63...+63]

Adjusts the shape of the LFO waveform if “Mod Src” is LFO.

p.5 “LFOShape”

Key Sync (LFO KeySync) [Off, Timbre]

Specifies whether the LFO will be reset at note-on. This parameter will be displayed and can be set if “Mod Src” is LFO.

p.5 “Key Sync (LFO KeySync)”

IniPhase (LFO Init Phase) [000...180°]

Specifies the starting position of the waveform. This parameter will be displayed and can be set if “Key Sync” is Timbre.

p.5 “IniPhase (LFO Init Phase)”

Ctrl Src (Control Source) [Off, Velocity...MIDI3]

Selects the control source used if “Mod Src” is set to Ctrl. The selected source will control the center frequency of the wah.

p.6 “Ctrl Src (Control Source)”

**6. S.2BndEQ (Stereo 2Band EQ): IFX
S.4BndEQ (Stereo 4Band EQ): MFX**

This is a stereo EQ for which the type can be selected independently.

When used in an insert effect, this will be a two-band stereo EQ.

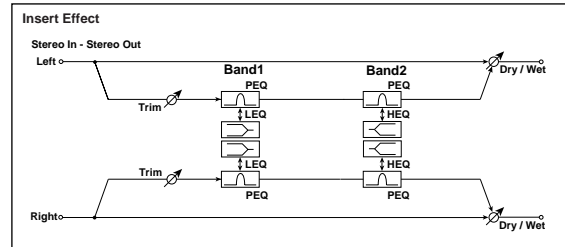

When used in the master effect, this will be a four-band stereo EQ. In this case, the equalizer type of two of the bands (B2 and B3) is fixed as peaking-type EQ.

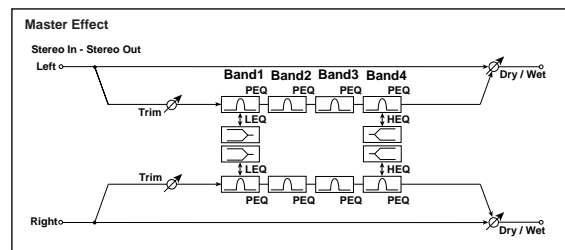

Trim [000...127]

Sets the input level of EQ.

B1 Type [Peaking, Shelv Lo]

Selects the EQ type of Band 1.

B2 Type/B4 Type [Peaking, Shelv Hi]

When used in an insert effect, selects the equalizer type of band 2.

When used in the master effect, selects the equalizer type of band 4. In this case, band 2 is fixed as a peaking-type EQ.

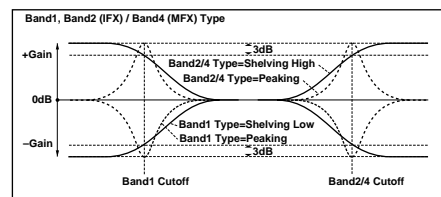

B1 Freq (B1 Frequency) [20Hz...20.0kHz]

Sets the center frequency of Band 1.

B1 Q [00.5...10.0]

Sets the bandwidth of Band 1. This parameter will be displayed and can be set if “B1 Type” is Peaking.

B1 Gain [-18.0...+18.0dB]

Sets the gain of Band 1.

B2 Freq (B2 Frequency) [20Hz...20.0kHz]

Sets the center frequency of Band 2.

B2 Q [00.5...10.0]
Sets the bandwidth of Band 2. This parameter will be displayed and can be set if "B1 Type" is Peaking.

B2 Gain  [-18.0...+18.0dB]
Sets the gain of Band 2.

B3 Freq (B3 Frequency) *only MFX* [20Hz...20.0kHz]
Sets the center frequency of Band 3.

B3 Q *only MFX* [00.5...10.0]
Sets the bandwidth of Band 3.

B3 Gain  *only MFX* [-18.0...+18.0dB]
Sets the gain of Band 3.

B4 Freq (B4 Frequency) *only MFX* [20Hz...20.0kHz]
Sets the center frequency of Band 4.

B4 Q *only MFX* [00.5...10.0]
Sets the bandwidth of Band 4.

B4 Gain  *only MFX* [-18.0...+18.0dB]
Sets the gain of Band 4.

7. Distort (Distortion)

This is a distortion effect with a three band EQ, giving you a broad range of variations.

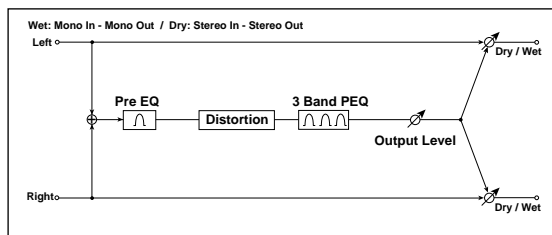

Gain  [000...127]
Sets the degree of distortion.

Pre Freq (Pre EQ Frequency) [20Hz...20.0kHz]
Sets the center frequency of Pre EQ.

Pre Q (Pre EQ Q) [00.5...10.0]
Sets the bandwidth of Pre EQ.

Pre Gain (Pre EQ Gain)  [-18.0...+18.0dB]
Sets the gain of Band PreEQ.

B1 Freq (B1 Frequency) [20Hz...20.0kHz]
Sets the center frequency of Band 1.

B1 Q [00.5...10.0]
Sets the bandwidth of Band 1.

B1 Gain  [-18.0...+18.0dB]
Sets the gain of Band 1.

B2 Freq (B2 Frequency) [20Hz...20.0kHz]
Sets the center frequency of Band 2.

B2 Q [00.5...10.0]
Sets the bandwidth of Band 2.

B2 Gain  [-18.0...+18.0dB]
Sets the gain of Band 2.

B3 Freq (B3 Frequency) [20Hz...20.0kHz]
Sets the center frequency of Band 3.

B3 Q [00.5...10.0]
Sets the bandwidth of Band 3.

B3 Gain  [-18.0...+18.0dB]
Sets the gain of Band 3.

OutLevel (Output Level) [000...127]
Sets the output level.

8. Cabi Sim (Cabinet Simulator)

This simulates the acoustical character of a guitar amp's speaker cabinet.

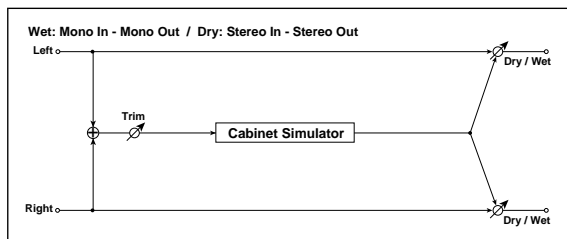

CabiType (Cabinet Type)

[TWD 1X8...US V30]

Selects the type of the cabinet.

TWD 1X8: Open-back cabinet with one 8" speaker

TWD 1X12: Open-back cabinet with one 12" speaker, typically used for blues.

TWD 4X10: Open-back cabinet with four 10" speakers.

BLK 2X10: Open-back cabinet with two 10" speakers.

BLK 2X12: American open-back cabinet with two 12" speakers.

AC15: Vox open-back cabinet with one 12" "Blue" speaker.

AC30: Vox open-back cabinet with two 12" "Blue" speakers.

AD412: VOX AD412 closed-back cabinet with four 12" speakers.

UK H30: Closed-back classic cabinet with four 30W 12" speakers

UK T75: Closed-back cabinet with four 75W 12" speakers.

US V30: Closed-back cabinet with four 30W 12" speakers.

Air

[000...127]

Sets the distance between the microphone and the Cabinet. Increasing this value will increase the distance.

Trim

[000...127]

Sets the input level.

9. Tube Sim (Tube PreAmp Simulator): IFX

S.TubSim (Stereo Tube PreAmp Simulator): MFX

This effect simulates a two-stage vacuum tube preamp. You can make individual settings for two vacuum tubes connected in series. This lets you create the warm sound typical of vacuum tubes.

When used in an insert effect, this will be a mono-in/mono-out effect.

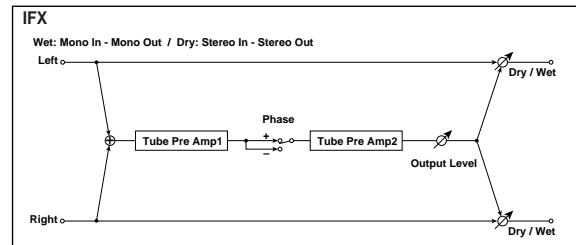

When used in the master effect, this will be a stereo-in/stereo-out effect.

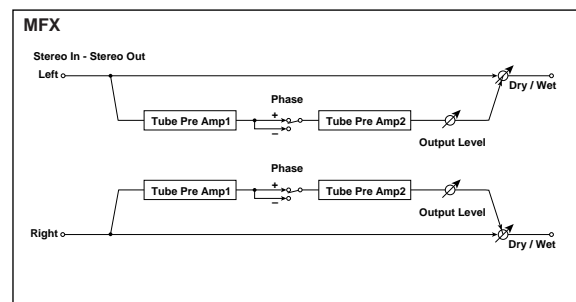

Tu1LoCut (Tube1 Low Cut)

[000...127]

Sets the cutoff frequency for the low cut filter of stage 1.

Tu1HiCut (Tube1 High Cut)

[000...127]

Sets the cutoff frequency for the high cut filter of stage 1.

Tu1 Gain (Tube1 Gain)

[-Inf, -40...+24dB]

Sets the input gain for stage 1.

Tu1 Bias (Tube1 Bias)

[000...100%]

Sets the bias voltage for stage 1.

This expresses the effect that changes in vacuum tube bias have on the distortion of the waveform. Higher settings of this value will produce distortion even at low gain levels. Since this will also change the overtone structure, you can use it to control the tonal character.

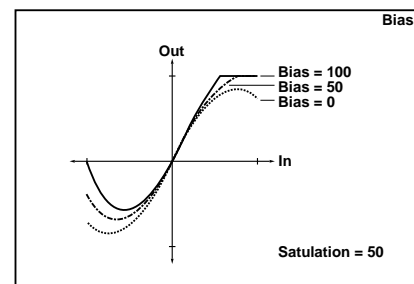

Tu1 Satu (Tube1 Saturation)

[000...100%]

Sets the input/output response for stage 1. With higher settings of this value, the waveform will change at high

gain levels, tending to cause distortion. Lower settings of this value will produce linear response.

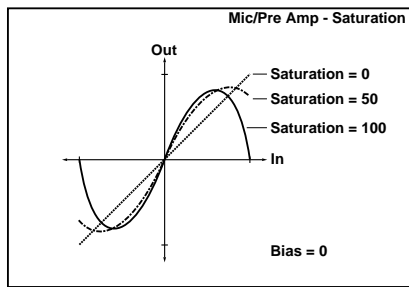

Phase [Normal, Inverted]

Turns phase reversal on/off. With the Invert setting, the phase of the signal will be inverted between stage 1 and stage 2. Since “Bias” is applied to the inverted signal in stage 2, this will change the tonal character. With the Normal setting, the phase will not be reversed.

Tu2LoCut (Tube2 Low Cut) [000...127]
Sets the cutoff frequency for the low cut filter of stage 2.

Tu2HiCut (Tube2 High Cut) [000...127]
Sets the cutoff frequency for the high cut filter of stage 2.

Tu2 Gain (Tube2 Gain) [-Inf, -40...+24dB]
Sets the input gain for stage 2.

Tu2 Bias (Tube2 Bias) [000...100%]
Sets the bias voltage for stage 2.

p.9 “Tu1 Bias (Tube1 Bias)”

Tu2 Satu (Tube2 Saturation) [000...100%]
Sets the input/output response for stage 2.

p.9 “Tu1 Satu (Tube1 Saturation)”

OutLevel (Output Level) [000...127]
Sets the output level.

10. S.Dcmtr (Stereo Decimator)

This effect creates a rough sound like a cheap sampler by lowering the sampling frequency and data bit length. You can also simulate noise unique to a sampler (aliasing).

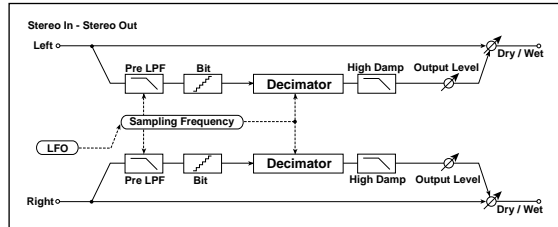

Pre LPF [Off, On]

Selects whether the harmonic noise caused by a decrease in sampling frequency is generated or not. If a sampler with a very low sampling frequency receives very high-pitched sound that could not be heard during playback, it could generate pitch noise that is unrelated to the original sound. Set “Pre LPF” to On to prevent this noise from being generated. If you set the “Fs” to about 3kHz and set “Pre LPF” to Off, you can create a sound like a ring modulator.

HighDamp [000...100%]
Sets the ratio of cut of the high range.

Fs [01.0k...48.0kHz]
Sets the sampling frequency.

Bit [04...24bit]
Sets the data bit length.

If you set a smaller value for the “Bit” parameter, the sound may be distorted. The volume level may also be changed. Use “OutLevel” to adjust the level.

OutLevel (Output Level) [000...127]
Sets the output level.

FsModInt (Fs Modulation Intensity) [-63...+63]
Sets the depth of sampling frequency LFO modulation.

LFO Sync (LFO BPM Sync) [Off, On]
Specifies whether the internal LFO cycle will synchronize to the tempo specified by the [TEMPO] knob or MIDI clock.

p.5 “LFO Sync (LFO BPM Sync)”

LFO Freq (LFO Frequency) [0.01...100.0Hz]
Sets the LFO speed. This parameter will be displayed and can be set if “Mod Src” is LFO and “BPM Sync” is Off.

p.5 “LFO Freq (LFO Frequency)”

SyncNote (LFO SyncNote) [8/1...1/64]
Sets the internal LFO frequency as a proportion of the tempo set by the [TEMPO] knob if “BPM Sync” is On.

p.5 “SyncNote (LFO SyncNote)”

LFO Wave (LFO Waveform) [Saw, Square, Triangle, Sine, S&H]
 Selects the internal LFO waveform.

☞ p.5 “LFO Wave (LFO Waveform)”

LFO Shape [-63...+63]
 Adjusts the shape of the LFO waveform.

☞ p.5 “LFOShape”

Key Sync (LFO KeySync) [Off, Timbre]
 Specifies whether the LFO will be reset at note-on.

☞ p.5 “Key Sync (LFO KeySync)”

IniPhase (LFO Init Phase) [000...180°]
 Specifies the starting position of the waveform if “Key-Sync” is Timbre.

☞ p.5 “IniPhase (LFO Init Phase)”

11. Reverb

This effect simulates acoustical ambience such as the reverberation of a hall.

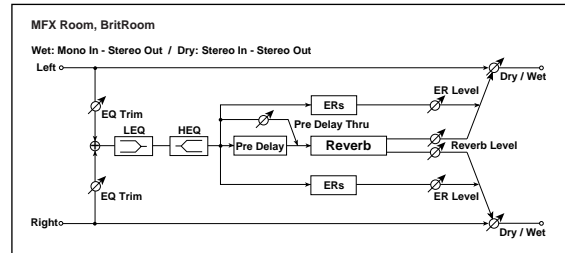
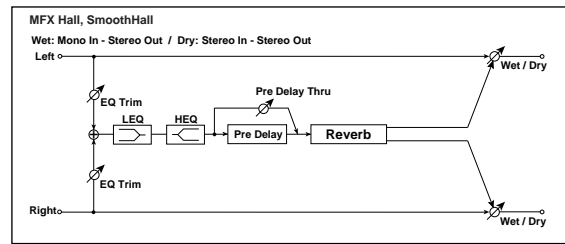

Type [Hall...BritRoom]

Selects the reverb type. The reverb types that you can select will differ depending on whether this effect is used in an insert effect or in the master effect.

Hall: Hall-type reverb, producing the reverberation of a mid to large-size concert or ensemble hall.

SmthHall ^{only MFX}: Hall-type reverb, producing the reverberation of a larger hall or stadium. The reverberation features a smooth release. Selectable only for the master effect.

Plate ^{only IFX}: Plate reverb. Selectable only for an insert effect.

WetPlate ^{only MFX}: Plate reverb that produces warm, dense reverberation. Selectable only for the master effect.

DryPlate ^{only MFX}: Plate reverb with a dry, light feel. Selectable only for the master effect.

Room: Room-type reverb with a tight feeling, and emphasis on the early reflections. By changing the balance between the early reflections and the reverberation, you can simulate different types of wall material.

BritRoom ^{only MFX}: Room-type reverb with a bright feeling, and emphasis on the early reflections (☞ Reverb Room). Selectable only for the master effect.

Rev Time (Reverb Time) 🏠
 [Hall or Plate: 00.1...10.0sec, Room: 00.1...03.0sec]

Sets the reverberation time. The selectable range of reverb time will depend on the “Type” setting.

High Damp [000...100%]
 Sets the damping amount in the high range.

PreDelay ^{only MFX} [000...200msec]
 Sets the delay time from the dry sound.

PrDlyThr (Pre Delay Thru) ^{only MFX} [000...127]
 Sets the mix ratio of non-delay sound.

Trim (Pre EQ Trim) only MFX [000...127]
Sets the EQ input level.

LoEQGain (Low EQ Gain) only MFX [-15.0...+15.0dB]
Sets the gain of Low EQ.

HiEQGain (High EQ Gain) only MFX [-15.0...+15.0dB]
Sets the gain of High EQ.

ER Level only MFX [000...127]
Sets the time taken from the original sound to the first early reflection. When used for the master effect, this is displayed and can be set only if Room or BritRoom is selected.

Rev Level (Reverb Level) only MFX [000...127]
Sets the reverberation level. When used for the master effect, this is displayed and can be set only if Room or BritRoom is selected.

12. EarlyRef (Early Reflections)

This effect is only the early reflection part of a reverberation sound, and adds presence to the sound. You can select one of the four decay curves.

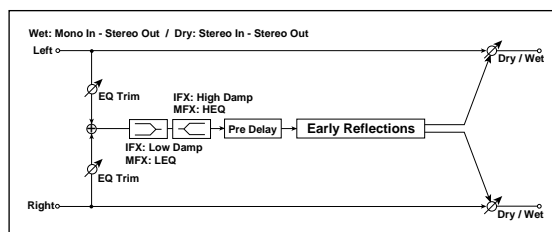

Type [Sharp, Loose, Modulate, Reverse]
Selects the decay curve for the early reflection.

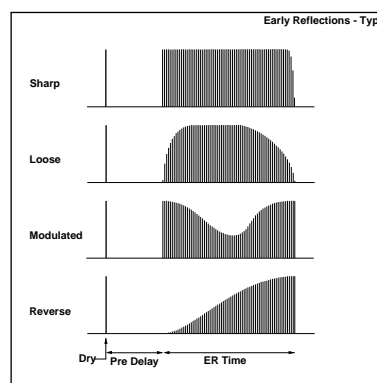

ER Time [IFX: 010...400msec/MFX: 010...800msec]
Sets the time from the original sound to the first early reflection. The range of this parameter will differ depending on whether the effect is an insert effect or a master effect.

PreDelay [IFX: 000...100msec/MFX: 000...200msec]
Sets the time taken from the original sound to the first early reflection. The range of this parameter will differ depending on whether the effect is an insert effect or a master effect.

Trim (Pre EQ Trim) [000...127]
Sets the input level of EQ applied to the effect sound.

LoEQGain (Low EQ Gain) only MFX [-15.0...+15.0dB]
Sets the gain of Low EQ.

HiEQGain (High EQ Gain) only MFX [-15.0...+15.0dB]
Sets the gain of High EQ.

HighDamp only IFX [000...100%]
Sets the damping amount in the high range.

Low Damp only IFX [000...100%]
Sets the damping amount in the low range.

13. LCR Dly (L/C/R Delay)

This multitap delay outputs three Tap signals to the left, center, and right respectively. You can also adjust the left and right spread of the delay sound.

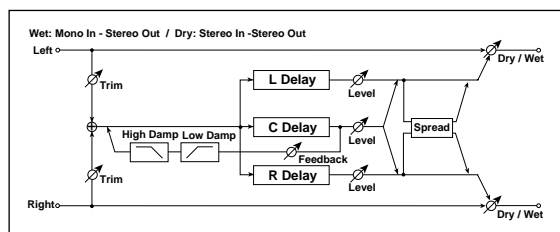

Spread

[000...127]

Sets the width of the stereo image of the effect sound. The stereo image is widest with a value of 127, and the effect sound of both channels is output from the center with a value of 0.

BPM Sync (Delay Time BPM Sync)

[Off, On]

Specifies whether the delay time will be synchronized. If this is On, the delay time will synchronize to the tempo or MIDI clock.

TimRatio (Time Ratio)

[BPM Sync Off: 000.5...400.0% (OVER)
BPM Sync On: 012.5...400.0% (OVER)]

Sets each delay time as a proportion relative to the "L Delay," "C Delay," and "R Delay" values. The available range will depend on whether "BPM Sync" is On or Off. For example if "TimRatio" is 50%, "L Delay" is 500 msec, "C Delay" is 700 msec, and "R Delay" is 1000 msec, the delay times will be 250 msec, 350 msec, and 500 msec respectively.



If you use this effect and a delay or chorus effect as the two insert effects, the delay times will be limited. If the delay times in conjunction with the "TimRatio" setting exceed the limit, "TimRatio" will indicate OVER.

L Delay, C Delay, R Delay (L, C, R Delay Time)

[BPM Sync Off IFX: 0000...1000msec
BPM Sync Off MFX: 0000...1400msec
BPM Sync On: 1/64...1/1]

These set the L, C, and R delay times. The delay time is determined by these settings and the "TimRatio" value. If "BPM Sync" is Off, these delay times are set in msec units. The range of this parameter will differ depending on whether the effect is an insert effect or a master effect.

If "BPM Sync" is On, these delay times are set as a timing resolution relative to the tempo specified by the [TEMPO] knob or MIDI clock.

L Level, C Level, R Level (L, C, R Delay Level)

[000...127]

These adjust the output level of the L, C, and R delays.

C Fback (C Feedback)

[000...127]

Sets the feedback amount of TapC.

High Damp

[000...100%]

Sets the damping amount in the high range.

Low Damp

[000...100%]

Sets the damping amount in the low range.

Trim

[000...127]

Sets the input level.

14. S.Delay (Stereo Delay)

This is a stereo delay, and can be used as a cross-feedback delay effect in which the delay sounds cross over between the left and right by changing the feedback routing.

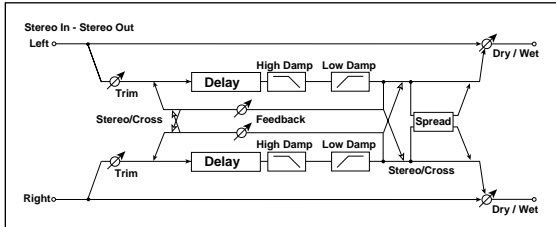

Type [Stereo, Cross]

Selects the delay type. With the Stereo setting, this will be a conventional stereo delay. With the Cross setting, this will be a cross-feedback delay in which the delay sound bounces between left and right.

BPM Sync (Delay Time BPM Sync) [Off, On]

Specifies whether the delay tempo will be synchronized.
 p.13 LCR Delay “BPM Sync (Delay Time BPM Sync)”

TimRatio (Time Ratio)
 [BPM Sync Off: 000.5...400.0% (OVER)
 BPM Sync On: 012.5...400.0% (OVER)]

p.13 LCR Delay “TimRatio (Time Ratio)”

L Delay, R Delay (L, R Delay Time)
 [BPM Sync Off IFX: 000...500msec
 BPM Sync Off MFX: 000...700msec
 BPM Sync Off: 1/64...1/1]

These set the left and right channel delay times. The delay time is determined by these settings and the “TimRatio” value.

If “BPM Sync” is Off, these delay times are set in msec units. The range of this parameter will differ depending on whether the effect is an insert effect or a master effect. If “BPM Sync” is On, these delay times are set as a timing resolution relative to the tempo specified by the [TEMPO] knob or MIDI clock.

Feedback [000...127]
 Sets the amount of feedback for the left and right channels.

HighDamp [000...100%]
 Sets the damping amount in the high range.

Low Damp [000...100%]
 Sets the damping amount in the low range.

Trim [000...127]
 Sets the input level.

Spread [000...127]
 Sets the width of the stereo image of the effect sound.
 p.13 LCR Delay “Spread”

15. AtPanDly (Auto Panning Delay)

This stereo delay effect pans the delay sound left and right using the LFO.

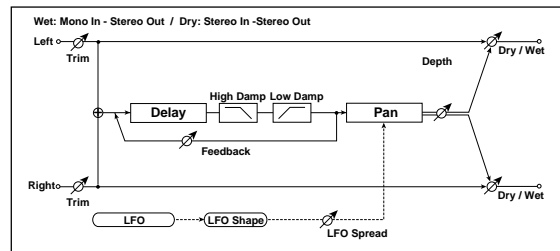

BPM Sync (Delay Time BPM Sync) [Off, On]

Specifies whether the delay tempo will be synchronized.
 p.13 LCR Delay “BPM Sync (Delay Time BPM Sync)”

TimRatio (Time Ratio)
 [BPM Sync Off: 000.5...400.0% (OVER)
 BPM Sync On: 012.5...400.0% (OVER)]

p.13 LCR Delay “TimRatio (Time Ratio)”

L Delay, R Delay (L, R Delay Time)
 [BPM Sync Off IFX: 0000...1000msec
 BPM Sync Off MFX: 0000...1400msec
 BPM Sync On: 1/64...1/1]

These set the left and right channel delay times. The delay time is determined by these settings and the “TimRatio” value.

If “BPM Sync” is Off, these delay times are set in msec units. The range of this parameter will differ depending on whether the effect is an insert effect or a master effect. If “BPM Sync” is On, these delay times are set as a timing resolution relative to the tempo specified by the [TEMPO] knob or MIDI clock.

Feedback [000...127]
 Sets the feedback amount for the left channel.

ModDepth (Modulation Depth) [000...127]
 Sets the depth of modulation.

LFO Sync (LFO BPM Sync) [Off, On]
 Specifies whether the internal LFO cycle will be synchronized with the tempo specified by the [TEMPO] knob or MIDI clock.

p.5 “LFO Sync (LFO BPM Sync)”

LFO Freq (LFO Frequency) [0.01...100.0Hz]
 Sets the internal LFO frequency if “BPM Sync” is Off.

p.5 “LFO Freq (LFO Frequency)”

SyncNote (LFO SyncNote) [8/1...1/64]
 Sets the internal LFO frequency as a proportion of the tempo set by the [TEMPO] knob if “BPM Sync” is On.

p.5 “SyncNote (LFO SyncNote)”

LFO Wave (LFO Waveform) [Saw, Square, Triangle, Sine, S&H]
 Selects the internal LFO waveform.

p.5 “LFO Wave (LFO Waveform)”

LFO Shape [-63...+63]
 p.5 “LFOShape”

Key Sync (LFO Key Sync) [Off, Timbre]

Specifies whether the LFO will be reset by note-on.

☞ p.5 “Key Sync (LFO KeySync)”

IniPhase (LFO Init Phase) [000...180°]

Sets the starting location of the waveform if “Key Sync” is Timbre.

☞ p.5 “IniPhase (LFO Init Phase)”

High Damp [000...100%]

Sets the damping amount in the high range.

Low Damp [000...100%]

Sets the damping amount in the low range.

Trim [000...127]

Sets the input level.

16. S.APnDly (Stereo Auto Panning Delay)

This is a stereo delay that uses an LFO to pan the delay sound between left and right.

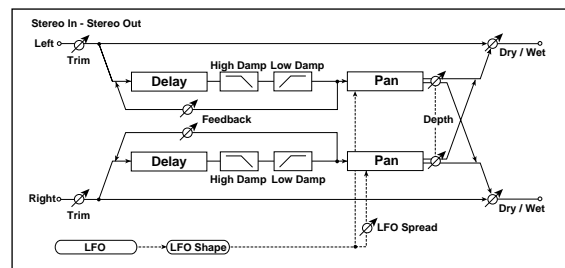

BPM Sync (DelayTime BPM Sync) [Off, On]

Specifies whether the delay tempo will be synchronized.

☞ p.13 LCR Delay “BPM Sync (Delay Time BPM Sync)”

TimRatio (Time Ratio)

[BPM Sync Off: 000.5...400.0% (OVER)]

[BPM Sync On: 012.5...400.0% (OVER)]

☞ p.13 LCR Delay “TimRatio (Time Ratio)”

L Delay, R Delay (L, R Delay Time)

[BPM Sync Off IFX: 000...500msec]

[BPM Sync Off MFX: 000...700msec]

[BPM Sync On: 1/64...1/1]

These set the left and right channel delay times.

☞ p.14 StDelay “L Delay, R Delay (L, R Delay Time)”

Feedback [000...127]

Sets the feedback amount for the left channel.

☞ p.14 StDelay “Feedback”

ModDepth (Modulation Depth) [000...127]

Sets the depth of modulation.

LFO Sync (LFO BPM Sync) [Off, On]

Specifies whether the internal LFO cycle will be synchronized with the tempo specified by the [TEMPO] knob or MIDI clock.

☞ p.5 “LFO Sync (LFO BPM Sync)”

LFO Freq (LFO Frequency) [0.01...100.0Hz]

Sets the LFO speed if “BPM Sync” is Off.

☞ p.5 “LFO Freq (LFO Frequency)”

SyncNote (LFO SyncNote) [8/1...1/64]

Sets the LFO frequency as a proportion of the tempo set by the [TEMPO] knob if “BPM Sync” is On.

☞ p.5 “SyncNote (LFO SyncNote)”

LFO Wave (LFO Waveform)

[Saw, Square, Triangle, Sine, S&H]

Selects the internal LFO waveform.

☞ p.5 “LFO Wave (LFO Waveform)”

LFOShape (LFO Shape) [-63...+63]

Adjusts the shape of the internal LFO waveform.

☞ p.5 “LFOShape”

Key Sync (LFO Key Sync) [Off, Timbre]

Specifies whether the LFO will be reset by note-on.

☞ p.5 “Key Sync (LFO KeySync)”

IniPhase (LFO Init Phase) [000...180°]
Sets the starting location of the waveform if “KeySync” is Timbre.

☞ p.5 “IniPhase (LFO Init Phase)”

LFOspread (LFO Spread) [-180...+180°]
Sets the phase difference between the left and right channels.

HighDamp [000...100%]
Sets the damping amount in the high range.

Low Damp [000...100%]
Sets the damping amount in the low range.

Trim [000...127]
Sets the input level.

17. ModDelay (Modulation Delay)

This stereo delay uses an LFO to sweep the delay time. The pitch also varies. You will obtain a delay sound with swell and shimmering. You can also control the delay time using a modulation source.

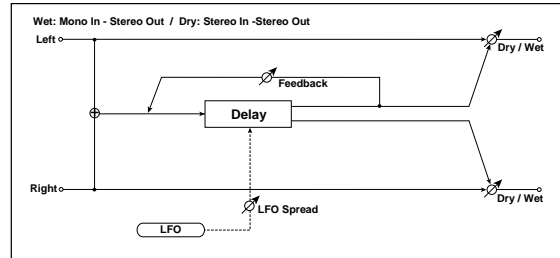

BPM Sync (DelayTime BPM Sync) [Off, On]

Specifies whether the delay tempo will be synchronized.
☞ p.13 LCR Delay “BPM Sync (Delay Time BPM Sync)”

TimRatio (Time Ratio)

[BPM Sync Off: 000.5...400.0% (OVER)
BPM Sync On: 012.5...400.0% (OVER)]

☞ p.13 LCR Delay “TimRatio (Time Ratio)”

L Delay, R Delay (L, R Delay Time)

[BPM Sync Off IFX: 000...980msec
BPM Sync Off MFX: 0000...1380msec
BPM Sync On 1/64...1/1]

☞ p.14 StDelay “L Delay, R Delay (L, R Delay Time)”

Feedback [000...127]

Sets the feedback amount for the left channel.

ModDepth (Modulation Depth) [000...127]

Sets the depth of LFO modulation.

LFO Freq (LFO Frequency) [0.01...100.0Hz]

Sets the LFO speed. Increasing this value will result in a faster frequency.

LFOspread (LFO Spread) [-180...+180°]

Sets the phase difference between the left and right channels.

18. S.ModDly (Stereo Modulation Delay)

This is a stereo modulation delay.

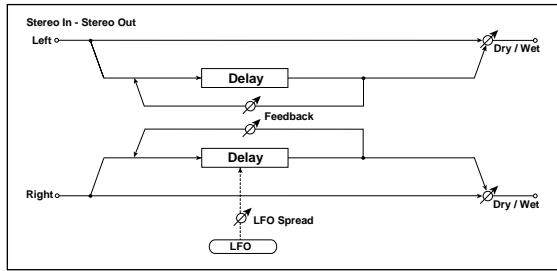

BPM Sync (DelayTime BPM Sync) [Off, On]

Specifies whether the delay tempo will be synchronized.

☞ p.13 LCR Delay “BPM Sync (Delay Time BPM Sync)”

TimRatio (Time Ratio)

[BPM Sync Off: 000.5...400.0% (OVER)

BPM Sync On: 012.5...400.0% (OVER)]

☞ p.13 LCR Delay “TimRatio (Time Ratio)”

L Delay, R Delay (L, R Delay Time)

[BPM Sync Off IFX: 000...480msec

BPM Sync Off MFX: 000...680msec

BPM Sync On 1/64...1/1]

☞ p.14 StDelay “L Delay, R Delay (L, R Delay Time)”

Feedback [000...127]

☞ p.14 StDelay “Feedback”

ModDepth (Modulation Depth) [000...127]

Sets the depth of internal LFO modulation.

LFO Freq (LFO Frequency) [0.01...100.0Hz]

Sets the internal LFO speed. Increasing this value will result in a faster frequency.

LFO Spred (LFO Spread) [-180...+180°]

Sets the phase difference between the left and right channels.

19. TapeEcho

This effect simulates a tape echo unit. The distortion and tonal change typical of magnetic tape are also reproduced.

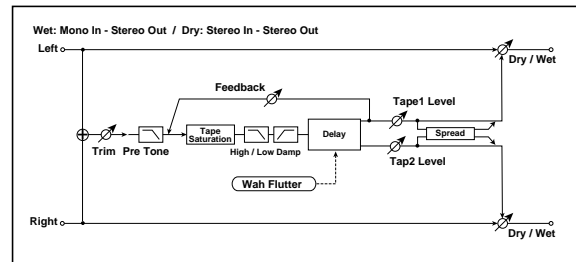

BPM Sync (DelayTime BPM Sync) [Off, On]

Specifies whether the delay tempo will be synchronized.

☞ p.13 LCR Delay “BPM Sync (Delay Time BPM Sync)”

TimRatio (Time Ratio)

[BPM Sync Off: 000.5...400.0% (OVER)

BPM Sync On: 012.5...400.0% (OVER)]

☞ p.13 LCR Delay “TimRatio (Time Ratio)”

Tap1Delay, Tap2 Delay(Tap1, Tap2 Delay Time)

[BPM Sync Off IFX: 000...980msec

BPM Sync Off MFX: 0000...1380msec,

BPM Sync On: 1/64... 1/1]

Sets the delay times for Tap1 and Tap2.

☞ p.13 LCR Delay “L Delay, C Delay, R Delay (L, C, R Delay Time)”

Tap1Lvl, Tap2 Lvl (Tap1 Level, Tap2 Level) [000...127]

Sets the Tap1 output level and Tap2 output level.

Feedback [000...127]

Sets the Tap1 feedback amount.

HighDamp [000...100%]

Sets the damping amount in the high range.

Low Damp [000...100%]

Sets the damping amount in the low range.

Trim [000...127]

Sets the input level.

Saturatn (Saturation) [000...127]

Sets the distortion amount.

Waw Freq (Wah Flutter Frequency) [0.01...100.0Hz]

Sets the frequency at which pitch variation will occur in Hz stepsl.

WawDepth (Wah Flutter Depth) [000...127]

Sets the depth of pitch variation.

Pre Tone [000...127]

Sets the tone of the input.

Spread [000...127]

Sets the width of the stereo image of the effect sound.

☞ p.13 LCR Delay “Spread”

20. S.Chorus (Stereo Chorus)

This effect adds thickness and warmth to the sound by modulating the delay time of the input signal. You can add spread to the sound by offsetting the phase of the left and right LFOs from each other.

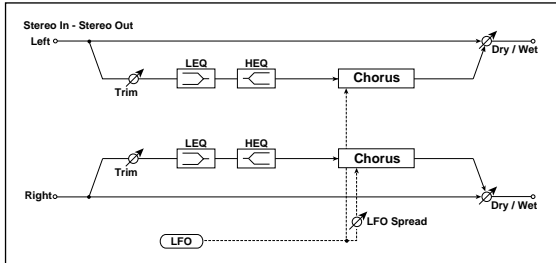

ModDepth (Modulation Depth)  [000...127]
Sets the depth of LFO modulation.

LFO Freq (LFO Frequency)  [0.01...100.0Hz]
Sets the internal LFO speed. Increasing this value will result in a faster frequency.

LFO Spread (LFO Spread) [-180...+180°]
Sets the LFO phase difference between the left and right.

PreDly L, PreDly R (Pre Delay L, R) [00.0...50.0msec]
Sets the delay times for the left and right channels.

Trim [000...127]
Sets the input level.

LoEQGain (Low EQ Gain) [-15.0...+15.0dB]
Sets the gain of Low EQ.

HiEQGain (High EQ Gain) [-15.0...+15.0dB]
Sets the gain of High EQ.

21. Ensemble

This effect produces a deep and spacious ensemble sound.

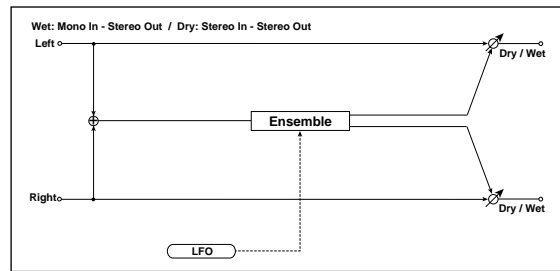

ModDepth (Modulation Depth)  [000...127]
Sets the depth of LFO modulation.

Speed  [001...127]
Sets the LFO speed.

22. S.Flanger (Stereo Flanger/Comb Filter)

This effect gives a significant swell and movement of pitch to the sound. It is more effective when applied to a sound with a lot of harmonics. This is a stereo flanger. You can add spread to the sound by offsetting the phase of the left and right LFOs from each other. This effect can also be used as a comb filter.

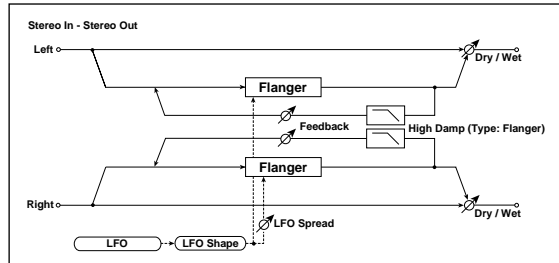

Type [Flanger, Comb]
Switches the effect between flanger and comb filter.

Delay [00.0...30.0msec]
Sets the delay time in millisecond steps when “Type” is set to Flanger.

 If this parameter is assigned to “Fx Knob,” setting “Type” to Comb will switch the assignment to Cutoff.

Cutoff (Cutoff Frequency) [000...127]
When “Type” is set to Comb, this sets the cutoff frequency of the comb filter.

ModDepth (Modulation Depth) [000...127]
Sets the depth of LFO modulation.

Feedback [000...127]
Sets the amount of feedback for the left and right channels.

Phase [+, -]
When “Type” is set to Flanger, this switches the phase of the output and feedback.

LFO Sync (LFO BPM Sync) [Off, On]
Specifies whether the internal LFO cycle will be synchronized with the tempo specified by the [TEMPO] knob or MIDI clock.

 p.5 “LFO Sync (LFO BPM Sync)”

LFO Freq (LFO Frequency) [0.01...100.0Hz]
Sets the LFO speed if “BPM Sync” is Off.

 p.5 “LFO Freq (LFO Frequency)”

SyncNote (LFO SyncNote) [8/1...1/64]
Sets the LFO frequency as a proportion of the tempo set by the [TEMPO] knob. This parameter will be displayed and can be set if “BPM Sync” is On.

 p.5 “SyncNote (LFO SyncNote)”

LFO Wave (LFO Waveform) [Saw, Square, Triangle, Sine, S&H]
Selects the internal LFO waveform.

 p.5 “LFO Wave (LFO Waveform)”

LFOShape (LFO Shape) [-63...+63]
Adjusts the shape of the internal LFO waveform.

 p.5 “LFOShape”

Key Sync (LFO KeySync) [Off, Timbre]
Specifies whether the LFO will be reset by note-on.

 p.5 “Key Sync (LFO KeySync)”

IniPhase (LFO Init Phase) [000...180°]
Sets the starting location of the waveform if “Key Sync” is Timbre.

 p.5 “IniPhase (LFO Init Phase)”

LFO Spred (LFO Spread) [-180...180°]
Sets the LFO phase difference between the left and right channels.

HighDamp [000...100%]
Sets the feedback damping amount in the high range if the “Type” is Flanger.

23. S.Phaser (Stereo Phaser)

This effect creates a swell by shifting the phase. It is very effective on electric piano sounds. You can add spread to the sound by offsetting the phase of the left and right LFOs from each other.

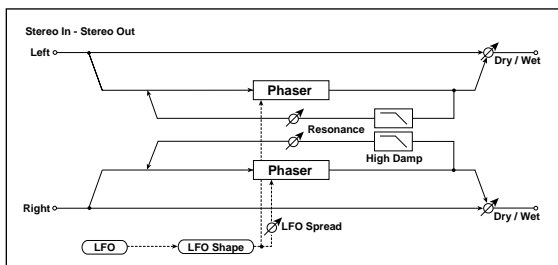

Type [Blue, U-VB]
Selects the phaser type.

Manual [000...127]
Sets the frequency to which the effect is applied.

ModDepth (Modulation Depth) [000...127]
Sets the depth of the internal LFO modulation.

Resonanc (Resonance) [000...127]
Sets the resonance amount.

Phase [+ , -]
Switches the phase of the output and feedback.

LFO Sync (LFO BPM Sync) [Off, On]
Specifies whether the internal LFO cycle will be synchronized with the tempo specified by the [TEMPO] knob or MIDI clock.

p.5 “LFO Sync (LFO BPM Sync)”

LFO Freq (LFO Frequency) [0.01...100.0Hz]
Sets the LFO speed if “BPM Sync” is Off.

p.5 “LFO Freq (LFO Frequency)”

SyncNote (LFO SyncNote) [8/1...1/64]
Sets the LFO frequency as a proportion of the tempo set by the [TEMPO] knob if “BPM Sync” is On.

p.5 “SyncNote (LFO SyncNote)”

LFO Wave (LFO Waveform) [Saw, Square, Triangle, Sine, S&H]
Selects the internal LFO waveform.

p.5 “LFO Wave (LFO Waveform)”

LFO Shape [-63...+63]
Adjusts the shape of the internal LFO waveform.

p.5 “LFOShape”

Key Sync (LFO KeySync) [Off, Timbre]
Specifies whether the LFO will be reset by note-on.

p.5 “Key Sync (LFO KeySync)”

IniPhase (LFO Init Phase) [000...180°]
Sets the starting location of the waveform if “Key Sync” is Timbre.

p.5 “IniPhase (LFO Init Phase)”

LFO Spred (LFO Spread) [-180...+180°]
Sets the LFO phase difference between the left and right channels.

HighDamp [000...100%]
Sets the feedback damping amount in the high range.

24. S.Tremol (Stereo Tremolo)

This effect modulates the volume level of the input signal. The effect is stereo, and offsetting the LFO of the left and right phases from each other produces a tremolo effect between left and right.

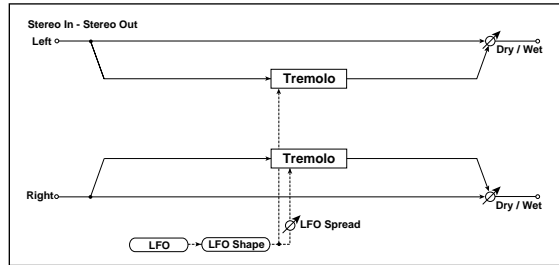

ModDepth (Modulation Depth) [000...127]
Sets the depth of internal LFO modulation.

LFO Sync (LFO BPM Sync) [Off, On]
Specifies whether the LFO cycle will be synchronized with the tempo specified by the [TEMPO] knob or MIDI clock.
p.5 “LFO Sync (LFO BPM Sync)”

LFO Freq (LFO Frequency) [0.01...100.0Hz]
Sets the internal LFO speed if “BPM Sync” is Off.
p.5 “LFO Freq (LFO Frequency)”

SyncNote (LFO SyncNote) [8/1...1/64]
Sets the internal LFO frequency as a proportion of the tempo set by the [TEMPO] knob if “BPM Sync” is On.
p.5 “SyncNote (LFO SyncNote)”

LFO Wave (LFO Waveform) [Saw, Square, Triangle, Sine, S&H]
Selects the internal LFO waveform.
p.5 “LFO Wave (LFO Waveform)”

LFOShape (LFO Shape) [-63...+63]
Adjusts the shape of the internal LFO waveform.
p.5 “LFOShape”

Key Sync (LFO KeySync) [Off, Timbre]
Specifies whether the LFO will be reset by note-on.
p.5 “Key Sync (LFO KeySync)”

IniPhase (LFO Init Phase) [000...180°]
Sets the starting location of the waveform if “Key Sync” is Timbre.
p.5 “IniPhase (LFO Init Phase)”

LFOSpred (LFO Spread) [-180...+180°]
Sets the internal LFO phase difference between the left and right channels.

25. S.RingMd (Stereo Ring Modulator)

This effect creates a metallic sound by applying the oscillators to the input signal. Use the LFO or Dynamic Modulation to modulate the oscillator to create a radical modulation. Matching the oscillator frequency with a note number will produce a ring modulation effect in specific key ranges.

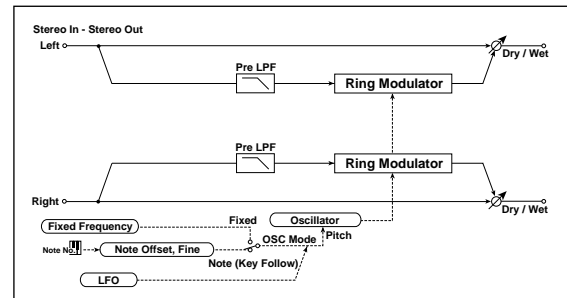

OSC Mode (Oscillator Mode) [Fixed, Note]
Switching between specifying the oscillator frequency and using a note number.

If this is set to Note, the oscillator frequency will track the note of the input signal.

FixedFrq (Fixed Frequency) [0...12.0kHz]
This parameter sets the oscillator frequency when “OSC Mode” is set to Fixed.

If this parameter is assigned to “Fx Knob,” setting “OSC Mode” to Note will switch the assignment to NoteOfst.

NoteOfst (Note Offset) [-48...+48]
Sets the pitch difference from the original note in semi-tone steps when “OSC Mode” is set to Note.

NoteFine (Note Fine) [-100...+100cent]
Sets the pitch difference from the original note in cent steps when “OSC Mode” is set to Note.

By setting “NoteOfst” and “NoteFine” so that the oscillator frequency will track the note that is input, you can produce a ring modulator effect with a correct scale.

OSC Wave (OSC Waveform) [Saw, Triangle, Sine]
Selects the oscillator waveform.

LFO Int (LFO Intensity) [-63...+63]
Sets the depth of internal LFO modulation.

LFO Sync (LFO BPM Sync) [Off, On]
Specifies whether the internal LFO cycle will be synchronized with the tempo specified by the [TEMPO] knob or MIDI clock.
p.5 “LFO Sync (LFO BPM Sync)”

LFO Freq (LFO Frequency) [0.01...100.0Hz]
Sets the internal LFO speed when “BPM Sync” is Off.
p.5 “LFO Freq (LFO Frequency)”

SyncNote (LFO SyncNote)  [8/1...1/64]

Sets the LFO frequency as a proportion of the tempo set by the [TEMPO] knob if “BPM Sync” is On.

 p.5 “SyncNote (LFO SyncNote)”

LFO Wave (LFO Waveform)

[Saw, Square, Triangle, Sine, S&H]

Selects the LFO waveform.

 p.5 “LFO Wave (LFO Waveform)”

LFOShape (LFO Shape)

[-63...+63]

Adjusts the shape of the internal LFO waveform.

 p.5 “LFOShape”

Key Sync (LFO Key Sync)

[Off, Timbre]

Specifies whether the LFO will be reset by note-on.

 p.5 “Key Sync (LFO KeySync)”

IniPhase (LFO Init Phase)

[000...180°]

Sets the starting location of the waveform if “Key Sync” is Timbre.

 p.5 “IniPhase (LFO Init Phase)”

Pre LPF

[000...127]

This parameter enables you to set the damping amount of the high range sound input to the ring modulator. If the input sound contains lots of harmonics, the effect may sound dirty. In this case, cut a certain amount of high range.

26. PitchSft (Pitch Shifter): IFX

S.PtcShft (Stereo Pitch Shifter): MFX

This effect changes the pitch of the input signal. You can select from three types: Fast (quick response), Medium, and Slow (preserves tonal quality). You can also create an effect in which the pitch is gradually raised (or dropped) using the delay with feedback.

If used for an insert effect, this will be mono-in/mono-out.

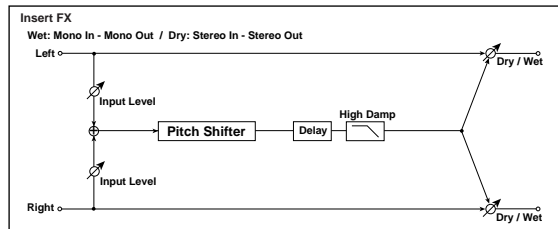

If used for the master effect, this will be stereo-in/stereo-out.

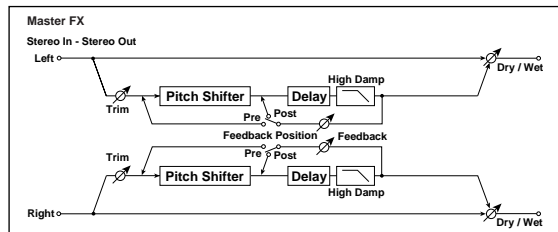

Pitch (Pitch Shift) 

[-24...+24]

Sets the pitch shift amount by steps of a semitone.

Fine

[-100...+100]

Sets the pitch shift amount by steps of a cent.

BPM Sync (DelayTime BPM Sync) only MFX

[Off, On]

Specifies whether the delay time will be synchronized.

 p.13 LCR Delay “BPM Sync (Delay Time BPM Sync)”

TimRatio (Time Ratio)  only MFX

[BPM Sync Off: 000.5...400.0% (OVER)]

[BPM Sync On: 012.5...400.0% (OVER)]

 p.13 LCR Delay “TimRatio (Time Ratio)”

Delay (Delay Time) only MFX

[BPM Sync Off: 000...500msec]

[BPM Sync On: 1/64... 1/1]

If “BPM Sync” is Off, this delay time is set in msec units.

If “BPM Sync” is On, this delay time is set as a timing resolution relative to the tempo specified by the [TEMPO] knob or MIDI clock.

FB Pos (FeedBack Position) only MFX

[Pre, Post]

Switches the feedback connection.

Feedback  only MFX

[000...127]

Sets the feedback amount.

Mode

[Slow, Medium, Fast]

This parameter selects the pitch shifter operating mode.

With Slow, tonal quality will not be changed too much. With Fast, the effect becomes a Pitch Shifter that has a quick response, but may change the tone. Medium is in

between these two. If you do not need to set too much pitch shift amount, set this parameter to Slow. If you wish to change the pitch significantly, use Fast.

HighDamp [000...100%]
Sets the damping amount in the high range.

Trim [000...127]
Sets the input level.

27. GrainSft (Grain Shifter): IFX S.GrnSft (Stereo Grain Shifter): MFX

This effect samples extremely brief fragments of the sound at a specified interval, and plays them as a loop. This is effective when used on external input sounds that are constantly changing.

If used for an insert effect, this will be mono-in/mono-out.

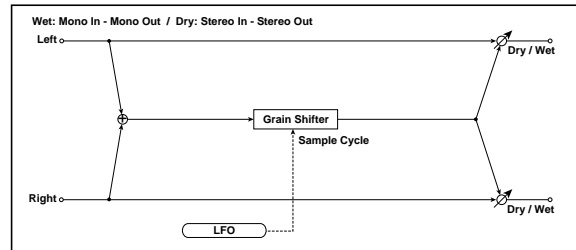

If used for the master effect, this will be stereo-in/stereo-out.

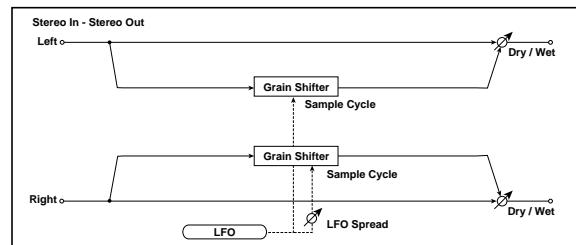

BPM Sync (Duration BPM Sync) [Off, On]

Specifies whether playback of the looped waveform will be synchronized. If this is On, the looped waveform will play in synchronization with the tempo or MIDI clock.

TimRatio (Time Ratio)

[BPM Sync Off: 000.5...400.0% (OVER)]

BPM Sync On: 012.5...400.0% (OVER)]

This specifies the length of the looped waveform relative to the "Duration" value.

Duration

[BPM Sync Off IFX: 000...500msec]

BPM Sync Off MFX: 000...350msec

BPM Sync On 1/64...1/1]

Sets the duration of the grain. The length of the waveform is determined by this setting and the "TimRatio" setting.

If "BPM Sync" is Off, this is set in msec units.

If "BPM Sync" is On, this is set as a timing resolution relative to the tempo specified by the [TEMPO] knob or MIDI clock.

If you use this in an insert effect and the other insert effect uses a delay or chorus effect, the waveform length will be limited.

If the "Duration" and "TimRatio" settings exceed the limit, an indication of OVER will appear for the "TimRatio."

LFO Sync (LFO BPM Sync) [Off, On]

Specifies whether the internal LFO cycle will be synchronized with the tempo specified by the [TEMPO] knob or MIDI clock.

p.5 “LFO Sync (LFO BPM Sync)”

LFO Freq (LFO Frequency) [0.01...100.0Hz]

If “BPM Sync” is Off, this specifies the cycle at which the waveform is switched in Hz units. The waveform length specified by “Duration” will play as a loop, and the waveform will switch at each cycle of the internal LFO.

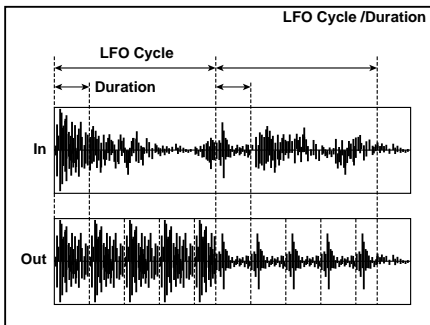

If this parameter is assigned to “Fx Knob,” turning “BPM Sync” On will switch the assignment to SyncNote.

SyncNote (LFO Sync Note) [8/1...1/64]

Sets the internal LFO frequency as a proportion of the tempo set by the [TEMPO] knob if “BPM Sync” is On.

p.5 “SyncNote (LFO SyncNote)”

Key Sync (LFO Key Sync) [Off, Timbre]

Specifies whether the LFO will be reset by note-on.

p.5 “Key Sync (LFO KeySync)”

IniPhase (LFO Init Phase) [000...180°]

Sets the starting location of the waveform if “Key Sync” is Timbre.

p.5 “IniPhase (LFO Init Phase)”

LFOspread (LFO Spread) only MFX [-180...+180°]

Sets the phase difference between the left and right channels. When used for the master effect, this is displayed and can be set this parameter.

28. S.Vibart (Stereo Vibrato)

This effect causes the pitch of the input signal to shimmer. Using the AutoFade allows you to increase or decrease the shimmering speed.

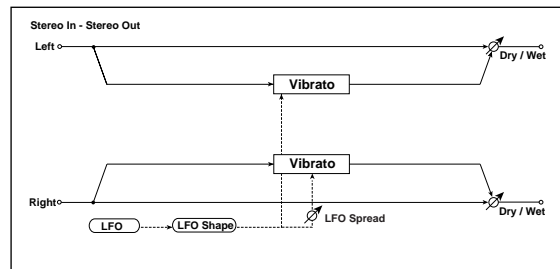

ModDepth (Modulation Depth) [000...127]

Sets the depth of internal LFO modulation.

LFO Sync (LFO BPM Sync) [Off, On]

Specifies whether the internal LFO cycle will be synchronized with the tempo specified by the [TEMPO] knob or MIDI clock.

p.5 “LFO Sync (LFO BPM Sync)”

LFO Freq (LFO Frequency) [0.01...100.0Hz]

Sets the LFO speed.

p.5 “LFO Freq (LFO Frequency)”

SyncNote (LFO Sync Note) [8/1...1/64]

Sets the internal LFO frequency as a proportion of the tempo set by the [TEMPO] knob if “BPM Sync” is On.

p.5 “SyncNote (LFO SyncNote)”

LFO Wave (LFO Waveform) [Saw, Square, Triangle, Sine, S&H]

Selects the internal LFO waveform.

p.5 “LFO Wave (LFO Waveform)”

LFOShape (LFO Shape) [-63...+63]

p.5 “LFOShape”

Key Sync (LFO Key Sync) [Off, Timbre]

Specifies whether the internal LFO will be reset by note-on.

p.5 “Key Sync (LFO KeySync)”

IniPhase (LFO Init Phase) [000...180°]

Sets the starting location of the waveform if “Key Sync” is Timbre.

p.5 “IniPhase (LFO Init Phase)”

LFOspread (LFO Spread) only MFX [-180...180°]

Sets the LFO phase difference between the left and right channels.

29. W.RotSpk (Rotary Speaker) **Double Size: IFX** RotrySpk (Rotary Speaker): **MFX**

This effect simulates a rotary speaker, and obtains a more realistic sound by simulating the rotor in the low range and the horn in the high range separately. The effect also simulates the stereo microphone settings.

 If you want to use this effect as an insert effect, you must select it for insert effect 1. In this case, you won't be able to use insert effect 2.

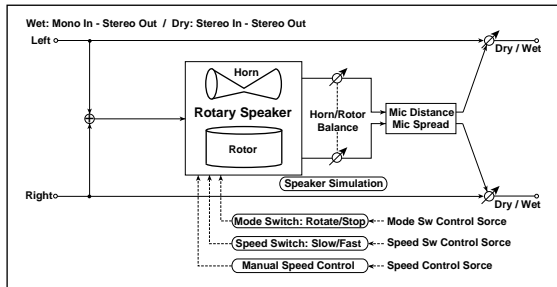

Mode Sw (Mode Switch)  [Rotate, Stop]
 Switches between speaker rotation and stop.

Ctrl Src (Mode Sw. Ctrl. Source) [Off, Velocity...MIDI3]
 Selects the modulation source that will control "Mode Sw."

 p.6 "Ctrl Src (Control Source)"

CtrlMode (Mode Sw. Ctrl. Mode) [Toggle, Moment]
 Specifies how the modulation source selected by "Ctrl Src" will be switched.

When "Ctrl Mode" = Toggle, the speaker rotates or stops alternately each time you press the pedal. Each time the value for the modulation source exceeds 64, the speaker rotates or stops alternately.

When "Ctrl Mode" = Moment, the speaker is rotating. It stops only when you press the pedal. Rotation will occur when the value of the modulation source is less than 64, and will stop when the value is 64 or greater.

Spk Ctrl (Speaker Control Type) [Switch, Manual]
 Selects whether the rotational speed will be controlled by a switch or manually.

Speed Sw (Speed Switch)  [Slow, Fast]
 Switches the speed of rotation if "Spk Ctrl" is set to Switch.

 If this parameter is assigned to "Fx Knob," setting "Spk Ctrl" to Manual will change the assignment to Speed.

Ctrl Src (Sw. Control Source) [Off, Velocity...MIDI3]
 If "Spk Ctrl" is set to Switch, this selects the modulation source that will switch the speaker rotation speed between slow and fast.

 p.6 "Ctrl Src (Control Source)"

CtrlMode (Sw. Ctrl. Mode) [Toggle, Moment]

If "Spk Ctrl" is set to Switch, this selects the switching mode of the modulation source that will switch the speaker rotation speed between slow and fast.

When "CtrlMode" = Toggle, the speed is switched between slow and fast each time you press the pedal. Slow/fast will alternate each time the value of the modulation source exceeds 64.

When "CtrlMode" = Moment, the speed is usually slow. It becomes fast only when you press the pedal. When a value for the modulation source is less than 64, "slow" speed is selected, and when the value is 64 or higher, "fast" is selected.

Speed  [001...127]

If "Spk Ctrl" is set to Manual, this specifies the speaker rotation speed.

 If this parameter is assigned to "Fx Knob," setting "Spk Ctrl" to Switch will change the assignment to Speed Sw.

Ctrl Src (Speed Ctrl.Source) [Off, Velocity...MIDI3]

If "Spk Ctrl" is set to Manual, this selects the modulation source that will control the speaker rotation speed.

 p.6 "Ctrl Src (Control Source)"

Ctrl Int (Speed Ctrl.Int) [-63...+63]

If "Spk Ctrl" is set to Manual, this specifies the depth to which the modulation source will control the speaker rotation speed.

H/R Bal (Horn/Rotor Balance) [Rotor, 1:99...99:1, Horn]
 Sets the level balance between the high-range horn and low-range rotor.

HrnAccel (Horn Acceleration) [000...127]

How quickly the horn rotation speed in the high range is switched. On a real rotary speaker, the rotation speed is accelerated or decelerated gradually after you switch the speed. The "Horn Acceleration" parameter sets the speed at which the rotation is accelerated or decelerated.

HrnRatio (Horn Ratio) [Stop, 0.50...2.00]

Adjusts the rotational speed of the high-frequency horn. A value of 1 is the normal speed, 0.5 is half speed, and Stop will stop the rotor.

RtrAccel (Rotor Acceleration) [000...127]

Determines how quickly the rotor rotation speed in the low range is switched. On a real rotary speaker, the rotation speed is accelerated or decelerated gradually after you switch the speed. The "HrnAccel" parameter sets the speed at which the rotation is accelerated or decelerated.

RtrRatio (Rotor Ratio) [Stop, 0.50...2.00]

Adjusts the (low-range side) rotor rotation speed. A value of 1 is the normal speed, 0.5 is half speed, and Stop will stop the rotor. RtrAccel (Rotor Acceleration)

MicDstnc (Mic Distance)  [000...127]

Sets the distance between the microphone and the rotary speaker. Increasing this value will increase the distance.

Spread

[000...127]

Sets the angle of left and right microphones.

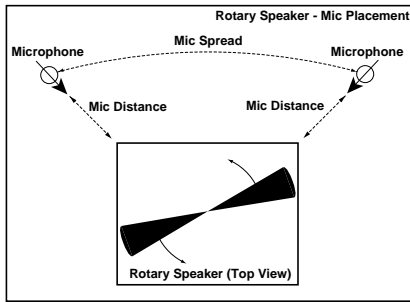

Trim

[000...127]

Sets the input level.

**30. W.TalkMd (Talking Modulation) Double Size: IFX
Talk Mod (Talking Modulation) : MFX**

This effect adds an unusual character, like a human voice, to the input signal.

If you want to use this effect as an insert effect, you must select it for insert effect 1. In this case, you won't be able to use insert effect 2.

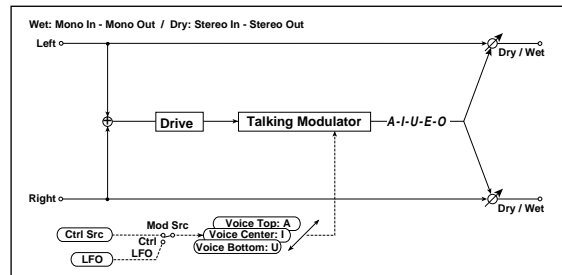

Vo.Ctr (Voice Control)

[Bottom, -62...-01, Center, +01...+62, Top]

Voice pattern control.

Vo.Top (Voice Top)

[A, I, U, E, O]

Selects a vowel sound at the top end of control.

Vo.Centr (Voice Center)

[A, I, U, E, O]

Selects a vowel sound in the center of control.

Vo.Bottom (Voice Bottom)

[A, I, U, E, O]

Selects a vowel sound at the bottom end of control.









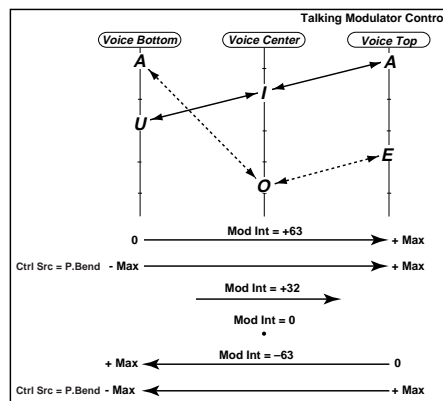



Example: If you set "Vo.Top" to A, "Vo.Cntr" to I, and "Vo.Btm" to U.

When "Mod Int" = +63, the vowel sound will change through "Aaa" (Voice Top) → "Eee" (Voice Center) → "Uuu" (Voice Bottom) according to the value of the modulation source.

When "Mod Int" = -63, the vowel sound will change through "Uuu" (Voice Bottom) → "Eee" (Voice Center) → "Aaa" (Voice Top) according to the value of the modulation source.

When "Mod Int" = 0, the vowel sound is fixed at "Eee" (Voice Center).



Resonanc (Resonance) 	[000...127]
Sets the intensity of resonance for the voice pattern. A larger value will add more character to the sound.	
Drive 	[000...127]
Sets the degree of distortion.	
Mod Src (Modulation Source)	[Auto, LFO, Ctrl]
Selects the modulation source.	
Mod Int (Modulation Intensity) 	[-63...+63]
Sets the depth of modulation produced by the modulation source.	
Response (Mod Response)	[000...127]
Adjusts the response to the modulation effect. A setting of 0 produces a slow response.	
Env Sens (Envelope Sensitivity)	[000...127]
When “Mod Src” is Auto, adjusts the sensitivity of auto operation.	
EnvShape (Envelope Shape)	[-63...+63]
When “Mod Src” is Auto, specifies the sweep curve.	
LFO Sync (LFO BPM Sync)	[Off, On]
Specifies whether the LFO cycle will be synchronized with the tempo specified by the [TEMPO] knob or MIDI clock.	
 p.5 “LFO Sync (LFO BPM Sync)”	
LFO Freq (LFO Frequency) 	[0.01...100.0Hz]
Sets the LFO speed if “BPM Sync” is Off.	
 p.5 “LFO Freq (LFO Frequency)”	
SyncNote (LFO SyncNote) 	[8/1...1/64]
Sets the LFO frequency as a proportion of the tempo set by the [TEMPO] knob if “BPM Sync” is On.	
 p.5 “SyncNote (LFO SyncNote)”	
LFO Wave (LFO Waveform)	[Saw, Square, Triangle, Sine, S&H]
Selects the LFO waveform.	
 p.5 “LFO Wave (LFO Waveform)”	
LFOShape (LFO Shape)	[-63...+63]
 p.5 “LFOShape”	
Key Sync (LFO Key Sync)	[Off, Timbre]
Specifies whether the LFO will be reset by note-on.	
 p.5 “Key Sync (LFO KeySync)”	
IniPhase (LFO Init Phase)	[000...180°]
Sets the starting location of the waveform if “Key Sync” is Timbre.	
 p.5 “IniPhase (LFO Init Phase)”	
Ctrl Src (Control Source)	[Off, Velocity...MIDI3]
Selects the control source. The selected source will control the filter if “Mod Src” is Ctrl.	
 p.6 “Ctrl Src (Control Source)”	

IMPORTANT NOTICE TO CONSUMERS

This product has been manufactured according to strict specifications and voltage requirements that are applicable in the country in which it is intended that this product should be used. If you have purchased this product via the internet, through mail order, and/or via a telephone sale, you must verify that this product is intended to be used in the country in which you reside.

WARNING: Use of this product in any country other than that for which it is intended could be dangerous and could invalidate the manufacturer's or distributor's warranty.

Please also retain your receipt as proof of purchase otherwise your product may be disqualified from the manufacturer's or distributor's warranty.