

KORG

PERFORMANCE SIGNAL PROCESSOR

A3

OWNER'S MANUAL

CONTENTS

BASIC USAGE

MAIN FEATURES OF THE A3	2
NAMES AND FUNCTIONS OF CONTROLS AND TERMINALS	4
BASIC USAGE	6
STRUCTURE OF EFFECT PROGRAM	10
OUTLINE OF OPERATION SYSTEM	11

EDIT PROGRAM

PLAY MODE	12
WHEN USING THE OPTIONAL FC6 FOOT CONTROLLER	15
PARAMETER EDIT MODE	18
MEMORIZING DATA (WRITE OPERATION)	19

PARAMETERS

EFFECT PARAMETERS	21
PERFORMANCE PARAMETERS	34

UTILITY

1. NAME	35
2. LEVEL	36
3. Pedal/Switch (P/SW)	36
4. CARD	37
5. MIDI	39

APPLICATION EXAMPLES

OTHER MESSAGES	41
OTHER FUNCTIONS OF THE FC6 ..	42
APPLICATION EXAMPLES USING THE A3	43
MIDI IMPLEMENTATION	46
RACK MOUNT INSTALLATION	46
TROUBLESHOOTING	47
SPECIFICATIONS AND OPTIONS	48
MIDI IMPLEMENTATION CHART	49

IMPORTANT SAFETY INSTRUCTIONS

WARNING—When using electric products, basic precautions should always be followed, including the following.

1. Read all the instructions before using the product.
2. To reduce the risk of injury, close supervision is necessary when a product is used near children.
3. Do not use this product near water - for example, near a bathtub, washbowl, kitchen sink, in a wet basement, or near a swimming pool, or the like.
4. This product should be used only with a cart or stand that is recommended by the manufacturer.
5. This product, either alone or in combination with an amplifier and headphones or speakers, may be capable of producing sound levels that could cause permanent hearing loss. Do not operate for a long period of time at high volume level or at a level that is uncomfortable. If you experience any hearing loss or ringing in the ears, you should consult an audiologist.
6. The product should be located so that its location or position does not interfere with its proper ventilation.
7. The product should be located away from heat sources such as radiators, heat registers, or other products that produce heat.
8. The product should be connected to a power supply only of the type described in the operating instructions or as marked on the product.
9. The power-supply cord of the product should be unplugged from the outlet when left unused for a long period of time.
10. Care should be taken so that objects do not fall and liquids are not spilled into the enclosure through openings.
11. The product should be serviced by qualified service personnel when:
 - A. The power-supply cord or the plug has been damaged; or
 - B. Objects have fallen, or liquid has been spilled into the product; or
 - C. The product has been exposed to rain; or
 - D. The product does not appear to operate normally or exhibits a marked change in performance; or
 - E. The product has been dropped, or the enclosure damaged.
12. Do not attempt to service the product beyond that described in the user-maintenance instructions. All other servicing should be referred to qualified service personnel.

SAVE THESE INSTRUCTIONS

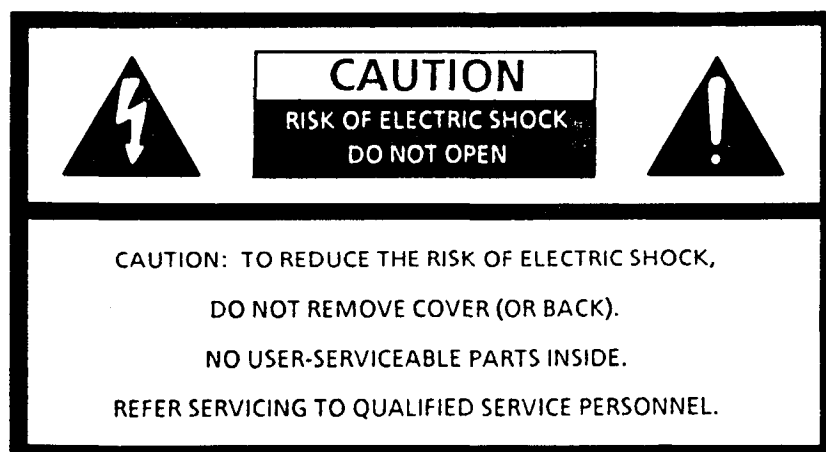

Congratulations and thank you for purchasing the KORG A3 Performance Signal Processor. To get the most out of this advanced instrument and enjoy it in its optimum condition for the longest possible time, we recommend that you read this manual thoroughly and carefully.

TABLE OF CONTENTS

MAIN FEATURES OF THE A3	2
NAMES AND FUNCTIONS OF CONTROLS AND TERMINALS	4
BASIC USAGE	6
1. Connection of Instrument and Amplifier	6
2. Selection of Internal Effect Programs	7
3. Creating Your Own Effects	8
STRUCTURE OF EFFECT PROGRAM	10
OUTLINE OF OPERATION SYSTEM	11
PLAY MODE	12
1. Program Selection	12
2. Individual Play	13
3. Performance Play	14
WHEN USING THE OPTIONAL FC6 FOOT CONTROLLER	15
PARAMETER EDIT MODE	18
MEMORIZING DATA (WRITE OPERATION)	19
EFFECT PARAMETERS	21
PERFORMANCE PARAMETERS	34
UTILITY	35
1. NAME	35
2. LEVEL	36
3. Pedal/Switch (P/SW)	36
4. CARD	37
5. MIDI	39
OTHER MESSAGES	41
OTHER FUNCTIONS OF THE FC6	42
APPLICATION EXAMPLES USING THE A3	43
(1) Guitar Setup (with the FC6)	43
(2) Keyboard Setup	44
(3) Mixer and Multi-track Recorder Setup	45
MIDI IMPLEMENTATION	46
RACK MOUNT INSTALLATION	46
TROUBLESHOOTING	47
SPECIFICATIONS AND OPTIONS	48
MIDI IMPLEMENTATION CHART	49

MAIN FEATURES OF THE A3

1. All-in-one Digital Multi-effect Unit

The A3 comes equipped with 20 built-in effect chains each using up to 6 different digital effects. There are 41 different types of effects from which to choose. The chains and individual parameter settings of each effect can also be edited and stored in the 100 program RAM memory.

2. Complete Digital Effect Processing

Full digital processing of effects is made possible by the newly developed DSP (Digital Signal Processor) installed in the A3, which eliminates the signal degradation that normally occurs when connecting several effect units together.

3. A Wide Variety of Effect Chains for use with Different Instruments

The 20 preset Chains in the A3 include typical studio and live multi-effect connections for guitar, bass, keyboards, vocals, drums and wind instruments. Normally, these effects require many different effect units and a complex patching system. However by plugging your instrument into the A3, the latest and most sophisticated studio/live effects configurations are available at the touch of a button.

4. Unlimited Possibilities with ROM Card Program Expansion and Soft-loading of New Effects and Chains

New Chains with brand new effects can be soft-loaded (stored in memory) from optional ROM Cards to expand the possibilities of the A3. Optional ROM cards also contain new preset Programs and by using a RAM Card the user can store edited settings to create his own library of unique effects.

5. Built-in Digital Noise Reduction

Irritating hum and noise during breaks in the input signal are automatically cut off by the built-in digital noise reduction.

6. 4 Times Over-sampling Digital Filter

Degradation in sound quality, due to multiple delay and distortion, is eliminated by the 4 times over-sampling digital filter. The filter preserves phase characteristics in the high frequencies and results in high-quality sound output.

7. Connection with Foot Controller FC6

Program change, Effect ON/OFF, as well as Individual Effects Parameter Settings can be controlled in real time by connecting the optionally available FC6 Foot Controller for ultimate control in live performance applications.

8. Performance Play Function

The A3 allows you to control the parameters of multiple effects simultaneously in its Performance Edit Mode for easy real time editing of complex effect chains.

9. Newly Developed Double Function Editors

We've made checking settings and editing Parameters extremely easy by including double functions editors which employ both rotary and push button operation. Editing and storing of even the most complex effect set-ups can be accomplished quickly.

10. Automatic Front Panel Input/Output Terminal Assignment

When connected, the front panel INPUT and PHONES terminals automatically override the rear panel input and output terminals.

NAMES AND FUNCTIONS OF

CONTROLS AND TERMINALS

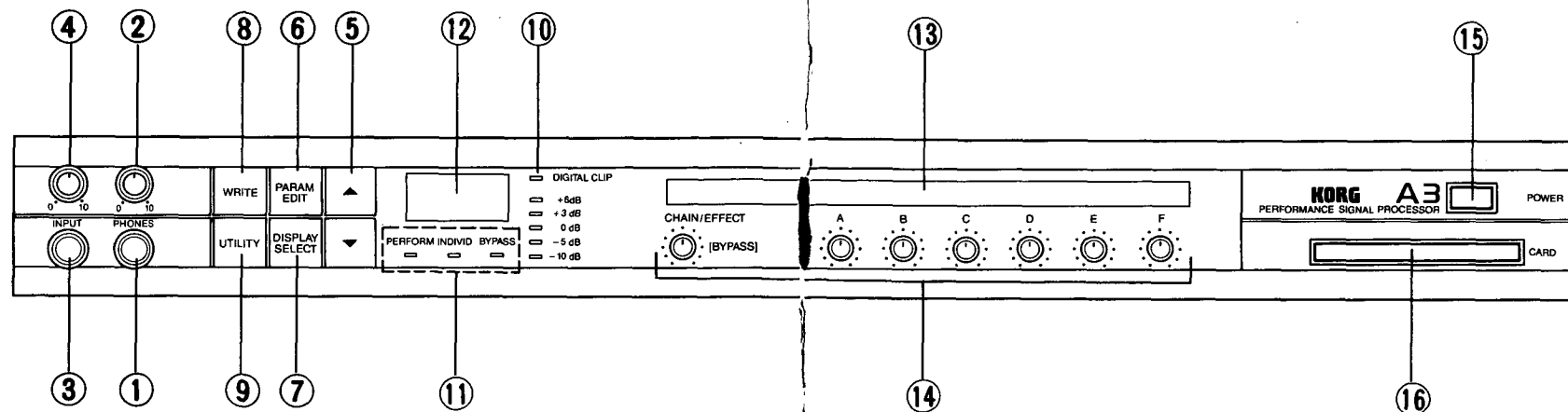

- (1) **Headphone jack**
 (2) **Headphone volume**
 (3) **Input**
 For line input of a guitar, keyboard, etc. The front panel input has priority over the rear panel input; when cords are connected to both inputs, the signal at the front panel input will be received and the one at the rear panel cancelled.
 (4) **Input level**
 For adjusting the volume of the input signal. Adjust while monitoring the level of the signal, indicated on the 6-segment LED level meter.
 (5) **Up/down keys**
 For selecting programs.
 (6) **Parameter edit key**
 For editing effect programs. (Refer to page 18.)

- (7) **Display select key**
 For selecting either Performance Play or Individual Play in the Play Mode. It can also be used to switch between indication of the parameter name and the parameter value while editing individual effects in the Effect Edit mode.
 (8) **Write key**
 For storing edited data to memory. (Refer to page 19.)
 (9) **Utility key**
 This is used to select the utility functions of the A3. (Refer to page 35.)
 (10) **Input indicator**
 For visual monitoring of the input level while making adjustments. Be careful to keep the input signal from consistently lighting up the DIGITAL CLIP LED.

- (11) **Mode indicator display**
 LED's indicate the currently selected mode. The PERFORM LED is lit when in the Performance mode, the INDIVID LED when in the Individual mode, and the BYPASS LED when Bypass has been selected.
 (12) **Program No. display**
 Indicates the program number.
 (13) **LCD Display**
 Indicates parameters, settings, etc.
 (14) **Double function editors**
 These function as two controls in one depending on whether they are rotated or pressed.
 1) CHAIN/EFFECT (BYPASS)
 Chains can be selected by turning this control.

- Pressing the control in the normal operation mode toggles the bypass function on and off. When editing individual effects in the Edit Effect mode, rotating the control varies of the selected effect. Pressing the control in this mode turns the effect on and off.
 2) A - F
 For setting the parameter values, effect variations, effect ON/OFF, etc.
 (15) **Power Switch**
 For turning the power on and off.
 (16) **Card slot**
 For use of optional RAM (MCR-03) and ROM cards.

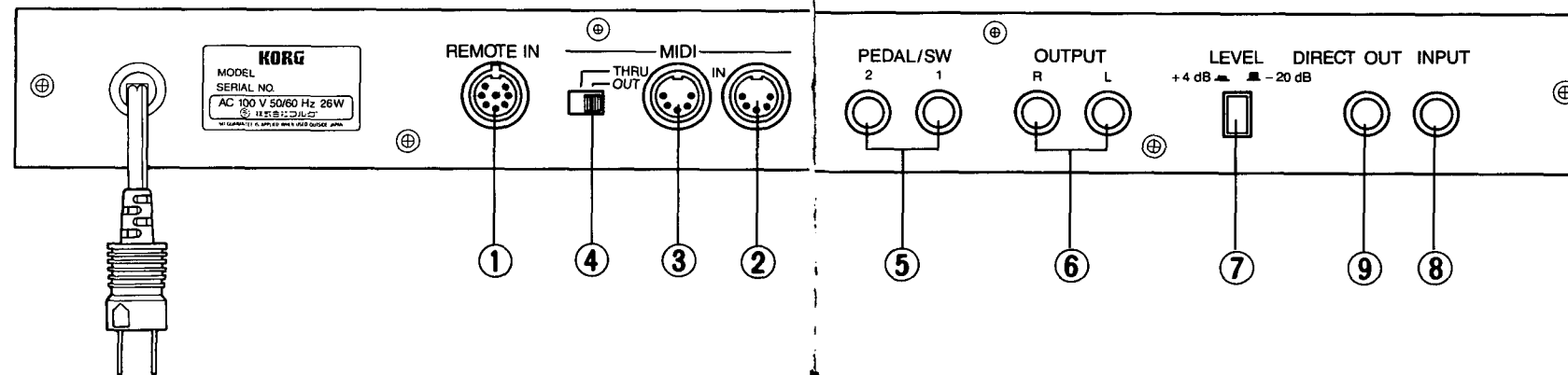

- (1) **Remote input terminal**
 For connection of optional FC6 Foot Controller, via special remote cable.
 (2) **MIDI IN terminal**
 (3) **MIDI OUT/THRU terminal**
 For connection of MIDI instruments.
 (4) **MIDI OUT/THRU selection switch**
 When set to OUT, MIDI messages from the A3 are transmitted via MIDI OUT; when set to THRU, MIDI messages received at the MIDI IN terminal are transmitted unaltered via MIDI THRU.

- (5) **Pedal/switch input jacks**
 For connection of a footswitch or volume pedal. Please see the Utility section (page 35) for detailed setup information.
 (6) **Outputs**
 For connection to amplifiers, mixers, etc. To take advantage of the sophisticated stereo effects of the A3, connect the two outputs to a stereo amplification system. For mono operation, connect to either output jack.

- (7) **Input level attenuator switch**
 For setting the nominal input level to match the type of instrument connected.
 -20dB
 Electric instruments with high-level output, such as electric guitars, keyboards, etc.
 Also audio equipment for the amateur/semi-professional level.
 +4dB
 Professional audio equipment.

- (8) **Input jack**
 For connection to a guitar, keyboard, etc.
 (9) **Direct output jack**
 For direct connection of input signals from the front or rear panel inputs. Since this signal is unprocessed and is not affected by the input volume control, it can be used for connection with a tuner, or for rerouting to other devices.

BASIC USAGE

NOTE: Turn power on only AFTER making connection with all other instruments and equipment.

1. Connection of Instrument and Amplifier

- (1) Connect the guitar, keyboard, etc. to one of the INPUT terminals (front or rear panel).
- (2) Connect the guitar amplifier or keyboard amplifier to the OUTPUT terminal on the rear panel.
- (3) Set the LEVEL SW of the rear panel to -20dB (switch should be in the raised position).

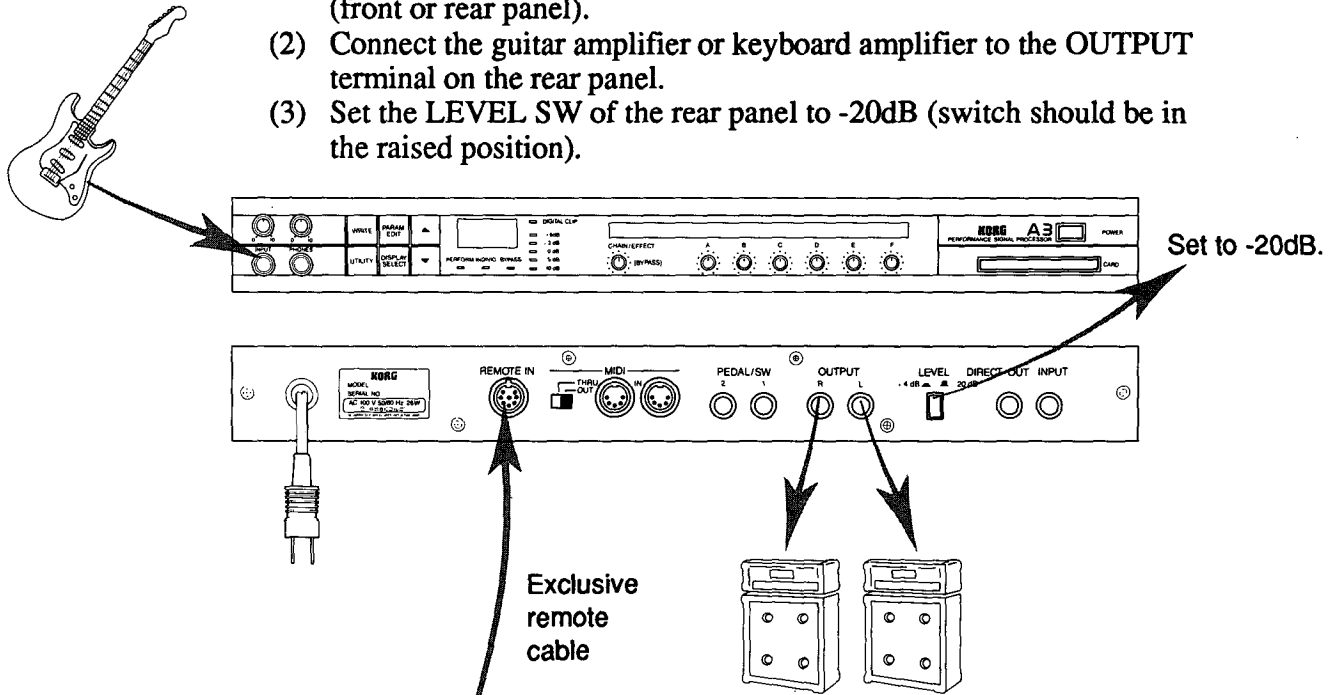

[Connection with the FC6]

The following notes and instructions apply to connection of the A3 to the optional FC6 Foot Controller.



- 1) The special connecting cable has a lock on one of its plugs and no lock on the other. Connect the plug with the lock to the FC6 and the other side to the A3.

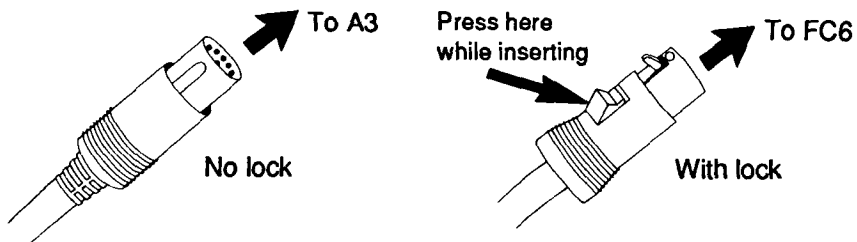

- 2) Set the power switch of the rear panel of FC6 to OFF/EXT. Electricity is supplied from A3.
- 3) The FC6's operation differs depending on the instrument to which it is connected. The operation mode for control by the A3 is automatically set when the FC6 is connected to the A3.

BASIC USAGE

2. Selection of Internal Effect Programs

The A3 is equipped with 100 different effect programs. To introduce yourself to the capabilities of the A3, play your connected instrument while selecting these programs.

- (1) Turn on the power. The display illustrated below will appear in the LCD and Program No. 1 will have been automatically selected. The program number is indicated in the left side of the display and the effect contents of the program are shown in the right side of the display.

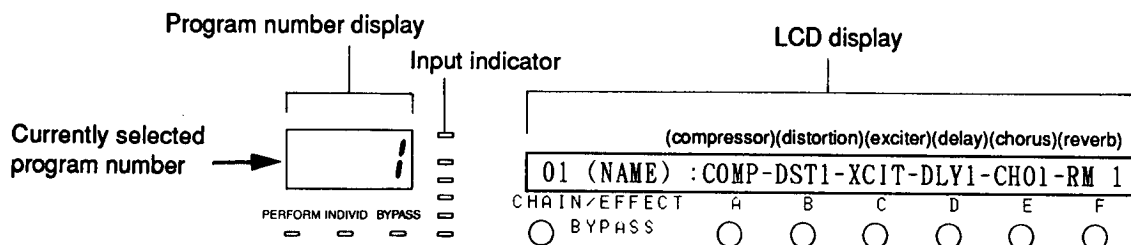

- (2) Play the connected instrument (guitar, etc.). The sound will be processed by Program number 1. Set the input level at this time. Set it such that the input indicator lights at around "+3" and "+6" when playing the loudest.
- (3) Select other programs and try them out with your connected instrument. The program number steps up by one each time the UP key is pressed and down by one each time the DOWN key is pressed.

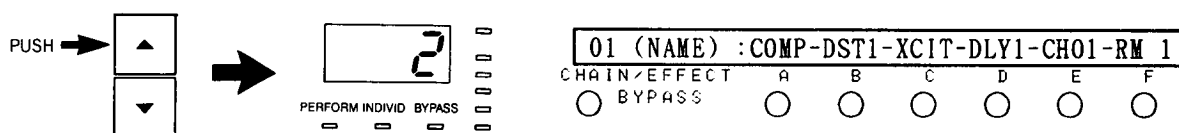

- (4) Each program is made up of a combination of several effects. The effects which you do not want to hear can be set to OFF. For example, Program 1 is connected to six separate effects, Compressor [COMP], Distortion 1 [DST1], Exciter [XCIT], Delay [DLY1], Chorus [CHO1], and Room Reverb [RM 1]. In this example, we'll turn the Distortion effect off.

- 1) Select Program number 1.
- 2) Press the "B" double function editor, directly under "DST1" in the display. The effect name in the display switches to lowercase letters ("dst1") to indicate that the Distortion effect is OFF. You can return it to the original setting by pressing the B double function editor again.

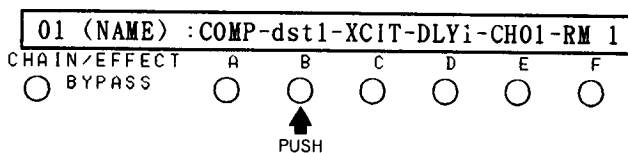

Other effects can be toggled ON and OFF in the same fashion by pressing the corresponding A - F double function editors.

The condition described above in which effect programs are selected is called the Play Mode. Refer to the Play Mode (page 12) for more detailed information on the functions of this mode.

BASIC USAGE

3. Creating Your Own Effects

Making Changes in the Preset Effect Programs

- (1) Select the program you wish to change by using the UP/DOWN keys. Select Program 1 for now.
- (2) Press the PARAM EDIT (Parameter Edit) key. The LED of this key lights up to indicate that the Parameter Edit Mode has been selected. (This is the mode in which you can change or edit the programs.)

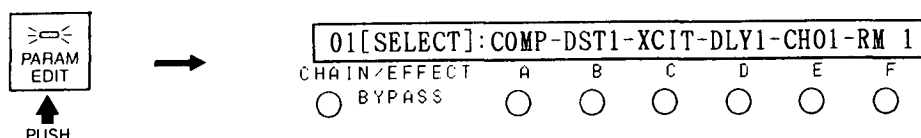

- (3) Individual effects can now be edited by pressing the double function editor directly below the name of the effect you wish to edit. Let's edit the Distortion effect for now. Select Distortion by pressing the "B" double function editor. The display will appear as shown below.

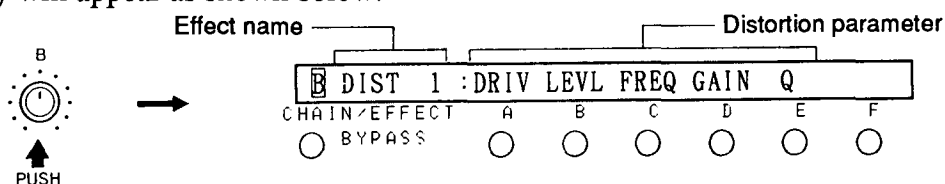

The name of the selected effect is indicated in the left side of the display and the changeable parameters of the effect (the aspects of the effect that determine its characteristics) are shown in the right side of the display.

- (4) Set the parameter to the desired value by rotating the double function editor under the parameter to be changed. For example, the degree of distortion in the Distortion effect is changed when rotating the A double function editor below "DRIV." (The display automatically and temporarily changes to the parameter value when the double function editor is rotated.)

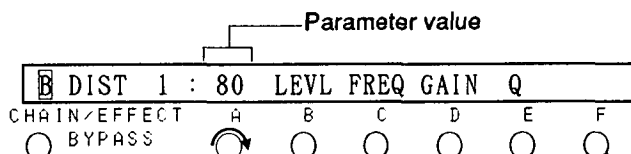

- (5) Change other parameters in the same way. Refer to the Effect Parameter page for more detailed information on the parameters of each effect.
- (6) Switching among variations of the effects. Some preset effects of the A3 have variations. For example, the Distortion effect has 4 variations: [DST1], [DST2], [OVD1], and [OVD2]. The variation can be changed (while Distortion is selected in the Parameter Edit Mode) by rotating the CHAIN/EFFECT double function editor. Select the desired variation and edit the parameters as you wish.
- (7) You can change to effects other than Distortion and their parameters by pressing the appropriate A - F double function editors. To return to the "[SELECT]" display (in which all effects of the selected program are shown), press the PARAM EDIT key twice. The first press exits the Parameter Edit Mode, and the second press returns to the mode again.

BASIC USAGE

- (8) Save the edited programs by executing the write operation. A recently edited program will return unaltered to its original program settings if you select another program without executing the write operation. On the other hand, original programs are safe from being erased despite any number of edits, as long as the write operation is not performed.

Creating Original Effect Programs from Scratch

- (1) Select any program number. For now, select Program number 1.

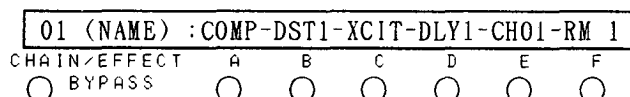

- (2) First, determine the connection pattern (chain) of the effect. The pattern or order in which the effects are connected is called a "chain." There are 20 chains (No. 1 - 20) already pre-programmed into the A3. (Refer to the chain list included with this manual.)
When you rotate the CHAIN/EFFECT double function editor, the chain number (shown on the left in the display) and the connected effects change together. Set this to Chain number 07 for now. The display changes as shown below.

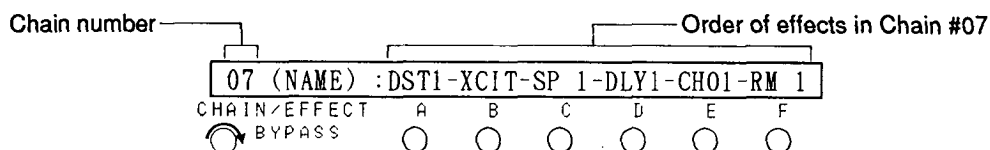

- (3) If there are effects in Chain #07 that you wish to be inactive, press the double function editors directly below them to turn them OFF. For example, when Chorus is not needed, press the E double function editor under [CHO1].

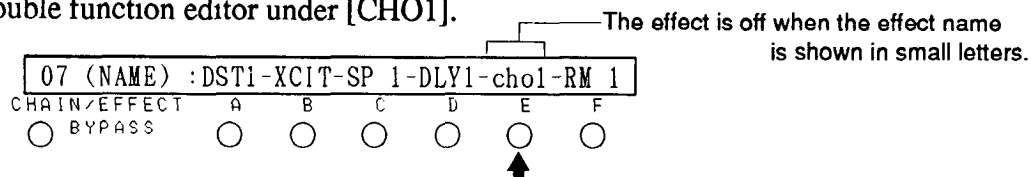

- (4) Different variations of the same basic effect type can be selected by rotating the double function editor below the appropriate effect name. For example, you can select from among the four types of Distortion/Overdrive by turning the A double function editor. Select the desired variation.
(5) Enter the Parameter Edit Mode to edit parameters and make detailed changes to the sound. Press the PARAM EDIT key and then select the effect you wish to edit by pressing the appropriate double function editor. The parameters of that effect will be shown. Adjust parameter settings by rotating the double function editor located under the parameter you wish to change.

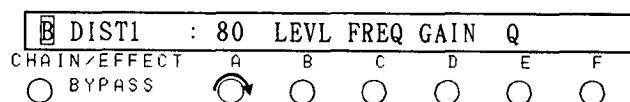

- (6) Make certain to write the program to memory when you are satisfied with the edits you have made. You can use a maximum of 7 characters to name your effect programs. (Refer to page 35 for details.)

STRUCTURE OF EFFECT PROGRAMS

About Effect Chains

The A3 permits connection of up to 6 effects for at once. The pattern, or order in which the effects are routed is called a "chain." The A3 has 20 chains (01 - 20) stored in its internal memory. As an example, Chain 01 is shown below.

< CHAIN 01 >

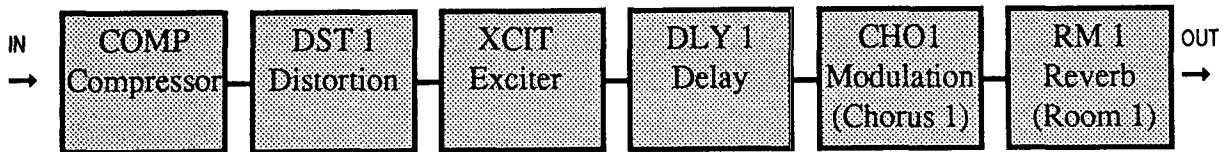

The chain can be given a program name, a master volume setting and a specified degree of noise reduction and then written to memory as an effect program. Additional chains and effect programs are available separately on optional memory cards.

Structure of Program

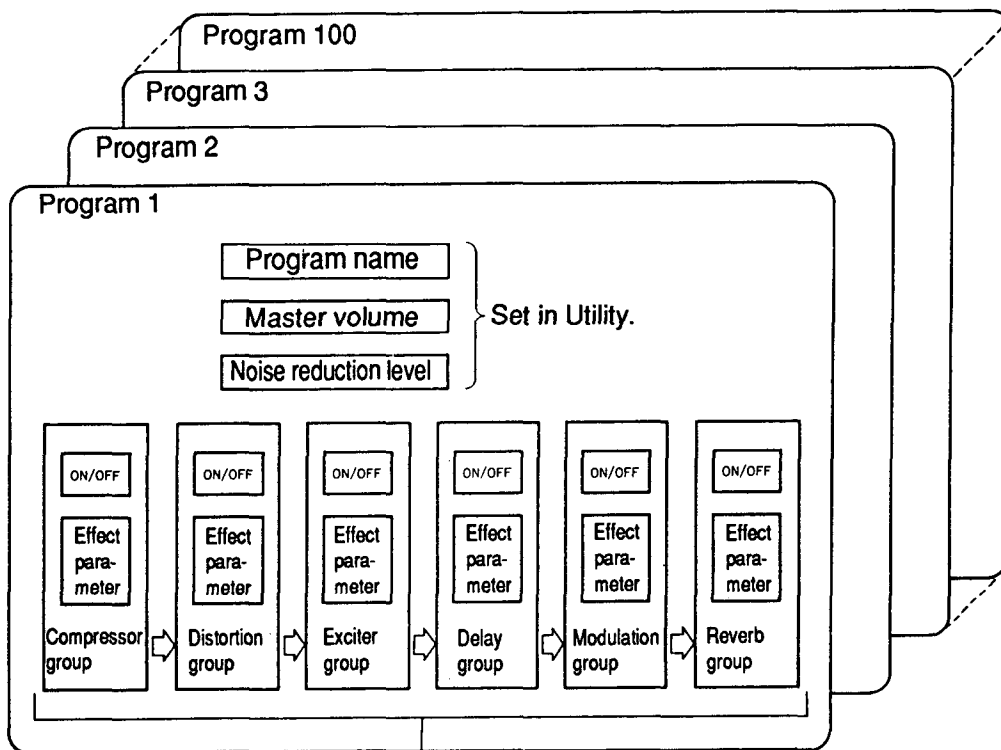

In the case of Chain #01.

OUTLINE OF OPERATION SYSTEM

The A3 has four modes: Play Mode, Parameter Mode, Utility Mode, and Write Mode. An outline of the functions of each mode is shown below. The modes can be entered by pressing the switches indicated in the arrows of the chart. Refer to pages 12 - 41 for more detailed information on each mode.

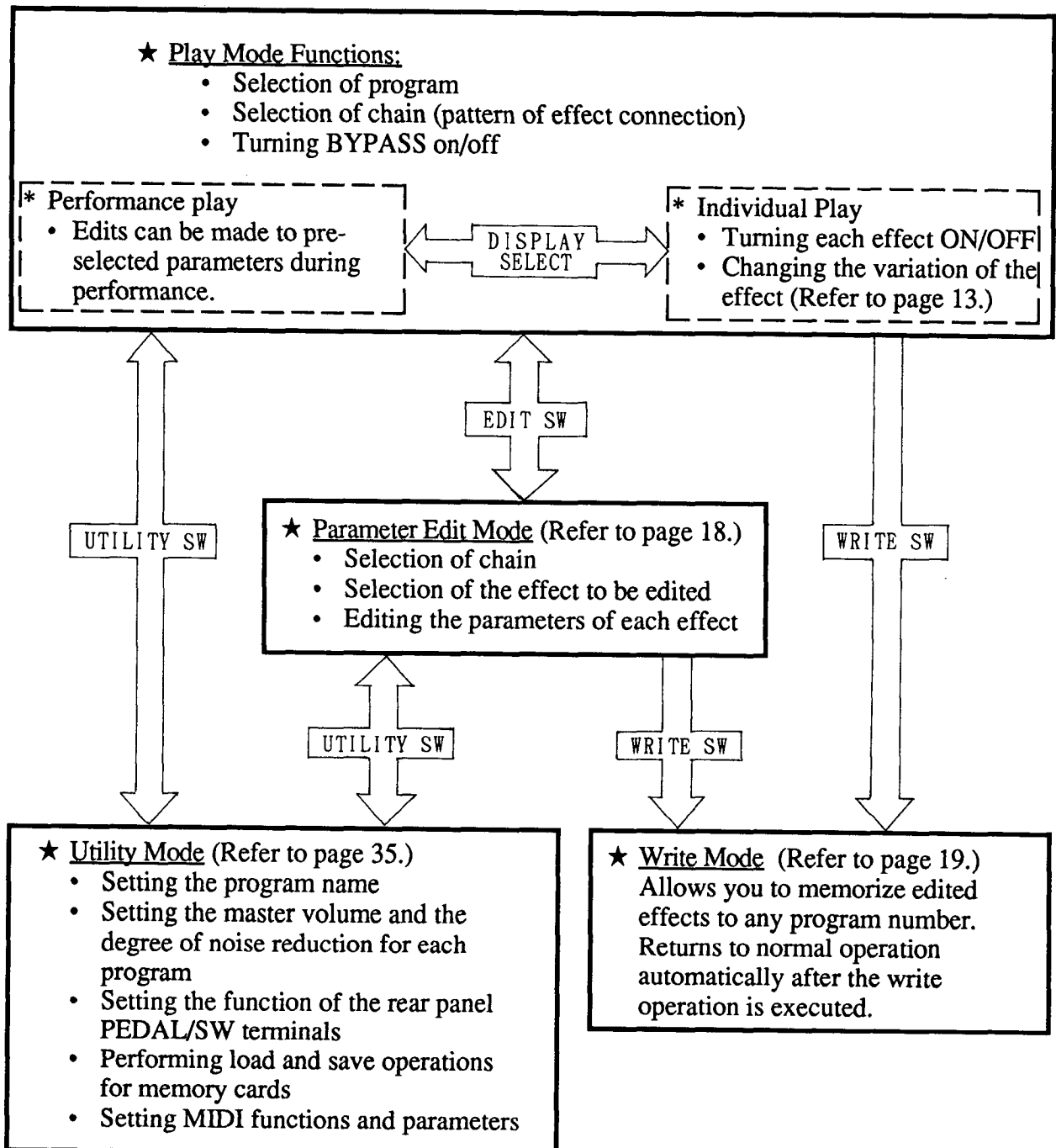

PLAY MODE

NOTE: The LED of the Parameter Edit key is off when in the Play mode.

In the Play mode you can select from any of 100 memorized effect programs. The A3 has 100 internal programs (No. 1 - 100). 100 additional programs (No. 101 - 200) can be saved to a memory card as well.

The following data are memorized in each program.

Programs

- **Name** Program name. (Set in the Utility mode. Refer to page 35.)
- **Chain** Effect connection patterns, such as COMPRESSOR → DISTORTION → EXCITER → CHORUS → DELAY → REVERB. The A3 has 20 pre-programmed patterns in internal memory.
- **Individual Parameter Data** .. Separate parameter data for each effect. For example, DISTORTION has parameters such as DRIVE, LEVEL, etc. whose values make up the parameter data for the effect.
- **Master Volume, Noise Reduction** Total volume and threshold level of noise reduction for the program (Set in the Utility mode. Refer to page 36.)

Effect programs can be selected for play in one of two ways:

Performance play and Individual play. *Individual play* allows you to turn each effect on or off separately within the program.

(This is the method described in the BASIC USAGE section.)

Performance play allows you to edit the effects in real time within the program, with the use of the double function editors.

(1) Program Selection

★ The Play Mode is selected automatically when the power of the A3 is turned on.

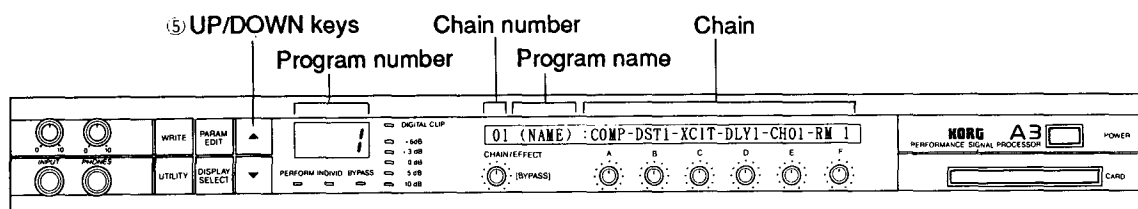

Programs can be selected by using the UP/DOWN keys.

- (1) When a memory RAM card is not being used:
Programs from 1 - 100 can be selected upon each press of the UP/DOWN keys.
 - (2) In the case where memory is being expanded (by use of a memory card):
Programs from 1 - 200 can be selected with the UP/DOWN keys.
- ★ The program number changes continuously when the UP or DOWN key is held down.
 - ★ You can advance through the program numbers in groups of 10 by pressing and holding down the UP key, then pressing the DOWN key.
To reverse through the program numbers in groups of 10, do just the opposite: press and hold down the DOWN key, then press the UP key.

PLAY MODE

(2) Individual Play

Individual play allows you control each of the effects in a program by: 1) turning each effect on or off individually within the program and 2) changing the variation of each effect (selecting one type of effect from the same effect group).

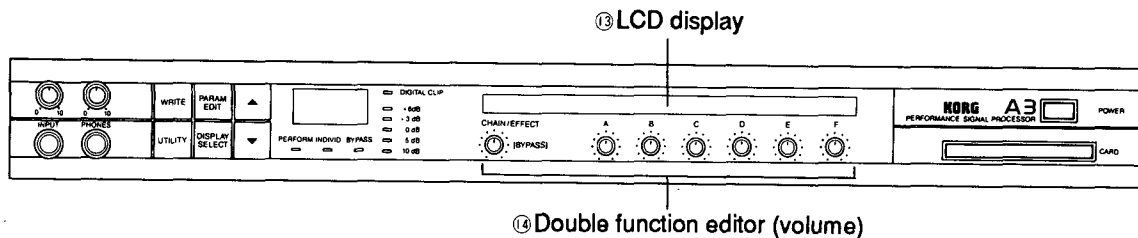

To select Individual play, press the DISPLAY SELECT key until the INDIVID LED is lit. Display (13) will appear as shown below.

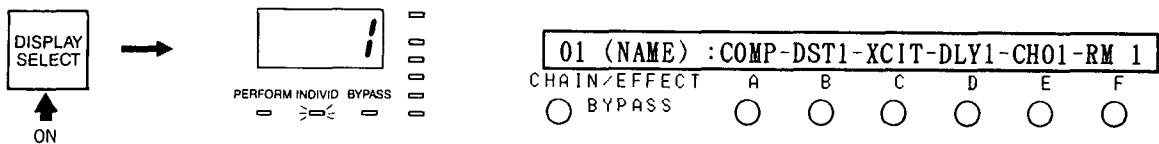

● Switching Effects ON and OFF

Each effect can be switched ON and OFF by pressing the double function editor (14) directly below the effect name indicated in the display (13). (Capital letters indicate that the effect is ON; lowercase indicates that the effect is OFF.)

● Changing the Effect Variation

The variation (or type) of effect can be changed by rotating the double function editor (14) directly below the effect name indicated in the display (13). For example, the Chorus effect can be changed between CHO1 (Chorus 1), CHO2, FLN1 (Flanger 1) and FLN2.

NOTE: Where an effect has only one type, no variations can be selected.

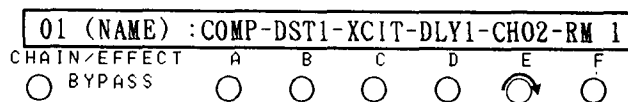

● Turning ON and OFF the Bypass Function

Pressing the CHAIN/EFFECT double function editor (BYPASS)(14) toggles the bypass function ON and OFF, and the BYPASS indicator LED (in the Mode Indicator display) is lit or unlit accordingly.

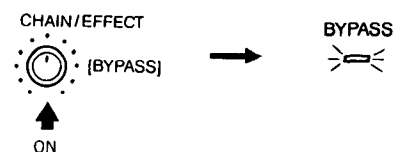

● Selecting Chains

Chains can be selected by rotating the CHAIN/EFFECT double function editor. The display indicates the effect connection of each chain.

In normal operation, the chain numbers change over a range of 1 - 20, but when programs Nos. 101 - 200 are selected from card memory, additional chain numbers stored to the card can be selected. Once you have loaded data from the card, these new chains can be used when writing programs 1 - 100, also.

PLAY MODE

(3) Performance Play

In the Performance Play Mode, each program of effects behaves as one integrated effect and can be controlled by editing general parameter groups that are characteristic of the entire program. This makes it easy to change or edit the total program, without having to edit individual parameters of each effect. (The parameters that can be edited in the Performance play Mode have been predetermined for each chain. Refer to page 36 and the chain list included with this manual for details.)

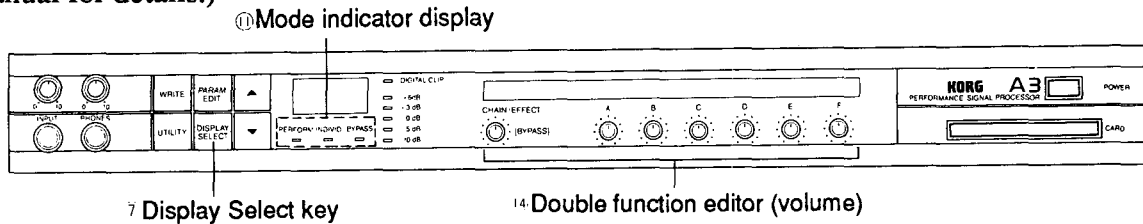

● Editing Performance Parameters

- 1) Set the A3 for Performance play by pressing the DISPLAY SELECT key (7).
The PERFORM LED on the mode indication display (11) will light up. The general parameter groups of the chain are shown in the display.

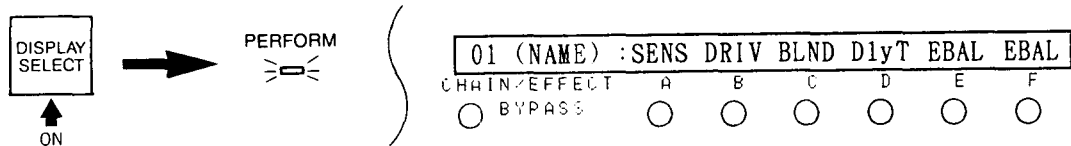

- 2) Rotate the double function editor directly below the parameter you wish to change.
For example, you can change the drive parameter of the effect program (indicated by "DRIV" in the display) by using the "B" double function editor.
In Performance Play, the parameter values are not indicated. The originally set value is returned to when the double function editor is set to the center position.



- 3) Other parameters are controlled in the same way.

● Selecting Chains

You can select chains (connection patterns of effects) by rotating the CHAIN/EFFECT double function editor.

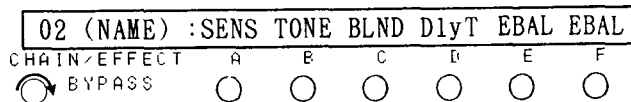

● Cancelling Effects with the Bypass Function

When pressing the CHAIN/EFFECT [BYPASS] double function editor (14) under the display, the BYPASS LED in the mode indication display (11) will light up and the sound will be sent unprocessed to the outputs. Press the double function editor again to release the BYPASS function and return to the effect-ON condition.

PLAY MODE

- ★ The effect NAMES are not shown in the display in the Performance Play Mode. Press the DISPLAY SELECT key (7) and go to the Individual Play Mode in order to view the effects in a chain.
- ★ Keep in mind that all edits and changes made to effects are lost when you select another program if you haven't written them to memory. (Refer to page 19 for instructions on how to write programs to memory.)

WHEN USING THE OPTIONAL FC6 FOOT CONTROLLER

Setting Up:

There are two modes by which the A3 can be controlled with the FC6: Manual 1 and Manual 2. The function of each mode is described below.

- [Manual 1]: Program change mode (Program changes on the A3 can be made from the FC6. See below for details on how to set up the FC6 for this mode.)
- [Manual 2]: Effect ON/OFF mode (The individual effects of a program on the A3 can be turned on or off from the FC6.)
- Switching between manual modes with the use of a foot switch, such as the PS - 1:
Connect the foot switch (PS - 1, etc.) to the SW 1 jack on the rear panel of the FC6. Switching between Manual 1 and 2 is done each time the foot switch is pressed.
- Switching between manual modes without the use of a foot switch:
Press the UTILITY key of the FC6 to check the mode status, shown by the LED. Next, press any of the pedal switches (A - F) to switch between Manual 1 and 2. Press the UTILITY key again after completing the setting.

(1) Program Selection [MANUAL 1]

The method of switching programs from the the FC6 differs depending on the mode selected, as described below. Select the mode you find most convenient or appropriate for your own purposes. The mode switch is located on the rear panel of the FC6.

(Set the FC6 to its Manual 1 mode before operating; see below for details.)

MODE 1

- In this mode, programs are grouped for selection into banks, with five consecutive programs making up one bank. The program-to-bank assignments are: programs No. 1 - 5, 6 - 10, 11 - 15, 16 - 20, 21 - 25, and so on.
 - Switch [A]: Selection of first program in the bank.
 - Switch [B]: Selection of second program in the bank.
 - Switch [C]: Selection of third program in the bank.
 - Switch [D]: Selection of fourth program in the bank.
 - Switch [E]: Selection of fifth program in the bank.
 - Switch [F]: Selection of bank. (Bank advances upon each press of the switch: [1], [6], [11], [16], [21], [96], [1])

PLAY MODE

For example, when the last selected program number is 18:

pressing switch [A] calls up program number 16;
pressing [B] calls up #17;
pressing [C] calls up #18;
pressing [D] calls up #19;
pressing [E] calls up #20;
and pressing [F] calls up the next bank, starting with program #21.

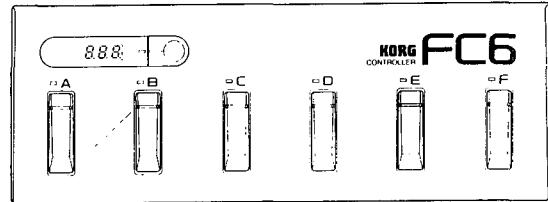

Each press of switch [F] changes the program number display and advances the bank selection as follows: #21, #26, #31, #36, and on up to #96. After #96, the selection “wraps around” to #1.

To decrease the bank number, press switch [F] while holding down switch [E].

NOTE: When decreasing the bank number in the above way, pressing switch [E] calls up the corresponding program number before the bank is changed.

MODE 2

- In this mode, program number selection can be increased or decreased in steps of ten or in individual steps.

SWA: Program number decreases by 10
SWB: Program number increases by 10
SWC: Program number decreases by 1
SWD: Program number increases by 1
SWE: no change
SWF: no change

For example, when the first program number is 23:

pressing switch [A] calls up program number 13;
pressing [B] calls up #23;
pressing [C] calls up #22;
pressing [D] calls up #24;
and pressing [E] or [F] have no change in the program selection.

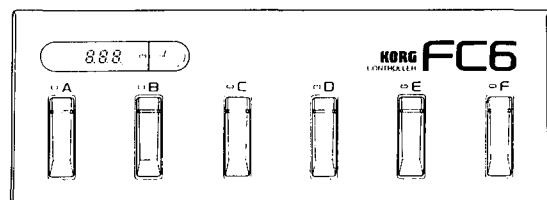

NOTE: The FC6 Foot Controller can be used to select any of the 100 programs available on the A3. However, when using memory cards with the A3 for expanded program selection, the FC6 cannot be used alone to select from the additional programs. When you wish to use the FC6 to select from the additional programs, you must first manually switch to that group from the front panel of the A3. For example, use the UP/DOWN keys on the front panel of the A3 to put the program number in the #101 - #200 range, then you can use the FC6 to select Programs #101 - #200.

PLAY MODE

(2) Individual Play [MANUAL 2]

The FC6 allows you to use your feet to turn each effect on and off or bypass all effects at once. The on/off status of each effect is also indicated by the LEDs of the FC6.

★ Switching Each Effect On and Off

- 1) Switch to the Effect ON/OFF mode (Manual 2) by using the operation mentioned above.
- 2) The LED changes as described below when pressing the pedal switch (A - F) corresponding to the effect to be switched on or off.

Red LED = Effect ON
Green LED = Effect OFF
Unlit LED = no effect available

- 3) All on/off switching of effects is also indicated in the display of the A3.

Capital letter = Effect ON
Lowercase letter = Effect OFF

NOTE: Effect variations cannot be selected from the FC6.

PARAMETER EDIT MODE

In the Parameter Edit Mode, the parameters of each effect in a chain can be selected and edited individually, and then saved as a program.

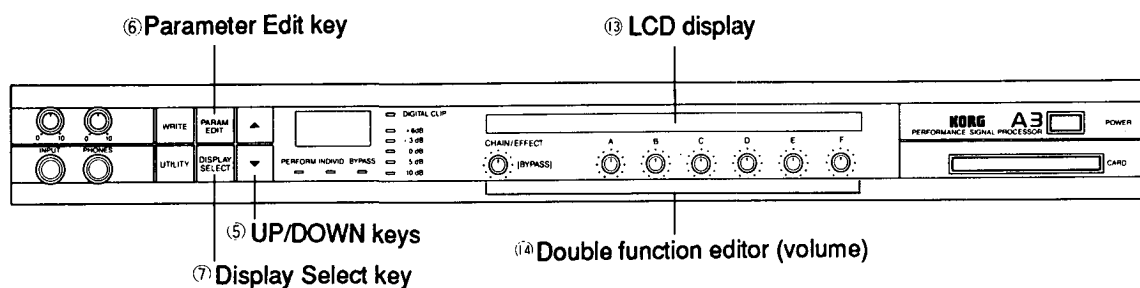

Setting Up:

To enter the Parameter Edit Mode while in either the Performance Play or Individual Play Mode, press the PARAM EDIT key. (The LED of the PARAM EDIT key will light up.)

NOTE: Since effects are not active in the BYPASS condition, turn BYPASS off before entering the Parameter Edit Mode.

● Effect Selection

- (1) After the Parameter Edit Mode has been selected, the display (13) shown below, or one similar, will appear.

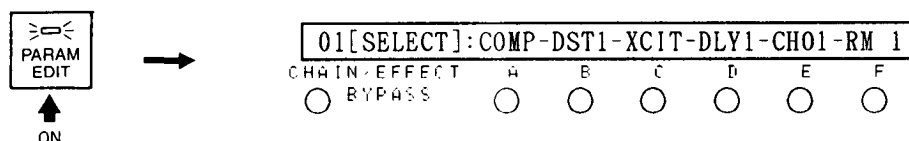

- (2) The chain can be selected by rotating the CHAIN/EFFECT double function editor or using the UP/DOWN keys. Then press the appropriate double function editor (14) directly below the effect to be edited. When selecting the Distortion effect [B], the display shown below will appear.

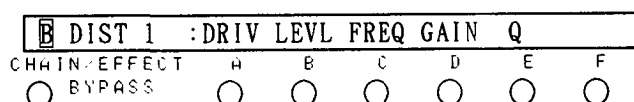

The names of the parameters are indicated when the effect has been selected.

- The variation or type of effect can be changed by rotating the CHAIN/EFFECT [BYPASS] double function editor.
- The currently indicated effect can be turned on or off by pressing the CHAIN/EFFECT [BYPASS] double function editor. (Capital letters = ON, lowercase letters = OFF)

PARAMETER EDIT MODE

- c. The parameter value is automatically indicated and can be changed when the double function editor directly below the parameter name is rotated. The UP/DOWN keys (5) can also be used, once you have begun editing a certain parameter, to step through parameter values in finer increments. The display returns automatically to the parameter name when you have finished editing the parameter value. Press the DISPLAY SELECT key (7) to display all the parameter names and parameter values at once. To illustrate selection and editing of a single parameter, the display shown below results when the parameter of the Distortion effect is edited.

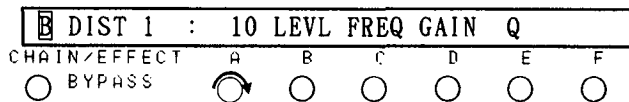

- 3) To edit other effects, press the appropriate double function editor (A - F) corresponding to the effect you wish to edit. The display below appears when the Exciter effect [C] is selected.

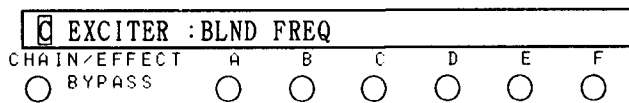

To return to the [SELECT] display, press the PARAM EDIT key twice. The first press exits the Parameter Edit Mode, and the second press returns to the mode again.

MEMORIZING DATA (WRITE OPERATION)

When you wish to keep the programs whose parameters you have edited, or when you wish to copy a program to another program number, use the Write function. Unless you use the Write function, programs you have edited will be erased when you select other programs.

Setting Up:

Confirm that the LED of the UTILITY key is not lit.

- In the event memory cards are not being used:

- 1) Press the WRITE key in order to enter the Write mode. You can do this from either of two conditions: 1) in the Parameter Edit mode, directly after editing effect parameters, or 2) when the program to be copied has been selected. The display shown below will appear when pressing the WRITE key after selecting Program number 6 for editing or play.

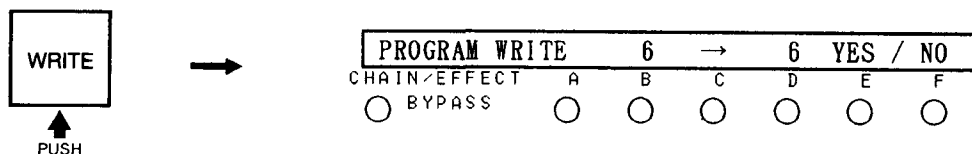

MEMORIZING DATA (WRITE OPERATION)

- 2) Select the program number to which you wish to store the newly edited program by using the UP/DOWN keys. Upon each press of one of the UP/DOWN keys, the number directly above the D double function editor will change. Holding down the key will cause the number to change continuously and rapidly until the maximum value is reached.

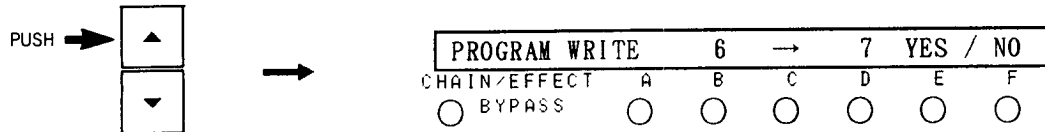

- 3) Press the double function editor directly below "YES" in the display to execute the Write function.
To abort the operation midway, press the double function editor directly below "NO" in the display.
- 4) The display below will appear when the write operation has been completed.

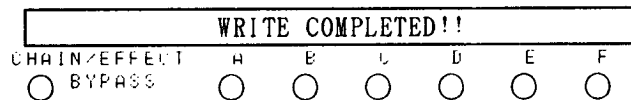

● In the event memory cards are being used:

The available memory space for storing programs is extended to Nos. 1 - 200 when using a memory card. However, there are certain limits to program storage that you should keep in mind:

- Edited Programs #1 - #100 can be written to Programs #1 - #100.
- Edited Programs #101 - #200 can be written to Programs #101 - #200.

Edited Programs #1 - #100 CANNOT separately be written to Programs #101 - #200 and vice versa. Doing this results in all 100 programs written together as a group. (Refer to page 37 for more details.)

All other instructions given in the section above, "In the event memory cards are not being used," apply to this section as well.

● Error messages in the Write operation

ROM CARD!

You cannot write edited programs to a ROM card. Use only RAM cards for writing data.

WRITE PROTECTED CARD

This means that the Write Protect switch of the RAM card is ON. Turn this switch OFF, then attempt the Write operation again.

EFFECT PARAMETERS

The A3 is equipped with 19 built-in effect groups with 41 different types of effects. These effects and their parameters make up the effect chains of the A3.

This section of the manual describes the function of each effect program and its individual parameters.

◆ REVERB GROUP [RM 1.2, HL 1.2, PL 1.2]

This effect provides spatial depth to a sound by simulating the ambience and reverberation characteristics of a concert hall or a room.

ROOM 1	:RevT	DAMP	PreD	L. EQ	H. EQ	EBAL
CHAIN/EFFECT	A	B	C	D	E	F
<input type="radio"/> BYPASS	<input type="radio"/>	<input type="radio"/>	<input type="radio"/>	<input type="radio"/>	<input type="radio"/>	<input type="radio"/>

○ Variations

- ROOM 1 [RM 1] : Room type reverb
- ROOM 2 [RM 2] : Room type reverb
- HALL 1 [HL 1] : Hall type reverb
- HALL 2 [HL 2] : Hall type reverb
- PLATE 1 [PL 1] : Plate type reverb
- PLATE 2 [PL 2] : Plate type reverb

○ Parameters

A (RevT)	REVERB TIME	0.1-5.0 [SEC]	Determines the reverb time.
B (DAMP)	HIGH DAMP	0-99	Adjusts the decay time of the high frequency reflections. A softer sound can be obtained by setting the parameter to high values.
C (PreD)	PRE DELAY	0-100 [mSEC]	Determines the time from the direct sound to the start of the reflecting sound(s).
D (L.EQ)	LOW EQ	-12-12 [dB]	Determines the gain which cuts or boosts low frequency range elements.
E (H.EQ)	HIGH EQ	-12-12 [dB]	Determines the gain which cuts or boosts high range frequency elements.
F (EBAL)	EFFECT BARANCE	0-100	Determines the output level of the effect sound. The effect sound becomes louder when the value of this parameter is set to high values.

EFFECT PARAPETERS

◆ COMPRESSOR GROUP [COMP]

This is a limiter effect which suppresses the high level attack transients of an input signal sound by compressing that signal. The effect also helps sustain or lengthen the sound by raising the level as a sound decays.

COMP	:SENS	ATCK	LEVL			
CHAIN/EFFECT	A	B	C	D	E	F
<input type="radio"/> BYPASS	<input type="radio"/>	<input type="radio"/>	<input type="radio"/>	<input type="radio"/>	<input type="radio"/>	<input type="radio"/>

○ Parameters

A (SENS)	SENSITIVITY	0-100	Determines the degree of the compressor effect. Input sound is output as it is, without processing, at 0; the effect is at its maximum at 100.
B (ATCK)	ATTACK	0-20	Determines the strength of the attack. The attack of the effect is faster at high values.
C (LEVL)	LEVEL	0-100	Determines the output level of the effect sound.

◆ DISTORTION GROUP [DST1, DST2, OVD1, OVD2]

This effect creates a typical distortion effect used mainly by guitarists. Two variation groups make up the program: the Distortion (or “fuzz”) group which creates a hard distortion effect and the Overdrive group which creates a mild distortion effect, similar to that of tube amplifiers.

DIST 1	:DRIV	LEVL	FREQ	GAIN	Q	
CHAIN/EFFECT	A	B	C	D	E	F
<input type="radio"/> BYPASS	<input type="radio"/>	<input type="radio"/>	<input type="radio"/>	<input type="radio"/>	<input type="radio"/>	<input type="radio"/>

○ Variations

- DISTORTION 1 [DST 1] : Distortion type effect
- DISTORTION 2 [DST 2] : Distortion type effect
- OVERDRIVE 1 [OVD 1] : Overdrive type effect
- OVERDRIVE 2 [OVD 2] : Overdrive type effect

○ Parameters

A (DRIV)	DRIVE	0-100	Determines the amount of distortion.
B (LEVL)	LEVEL	0-100	Determines the output level of the effect sound. The larger this value is, the greater the effect sound becomes.
C (FREQ)	FREQUENCY	0.55-8.00 [KHz]	Determines the center frequency to boost or cut.
D (GAIN)	GAIN	-12- +12 [dB]	Determines the degree to which the frequency is boosted or cut.
E (Q)	Q	2.0-10.0	Determines the effective range of boost or cut. The effective range gets larger when this is set to a high value.

EFFECT PARAMETERS

◆ DELAY GROUP [DLY 1, DLY 2, DLY 3]

The three delay effects in this group are identical in their parameters but are set to different delay times in their factory settings. This is for reference and to aid in user programming.

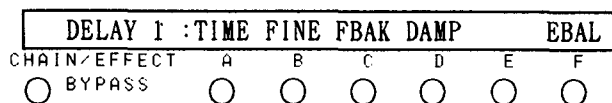

○ Variations

DELAY 1 [DLY 1]: Ideal for long delay effects.

DELAY 2 [DLY 2]: Ideal for short delay effects.

DELAY 3 [DLY 3]: Ideal for doubling effects.

○ Parameters

A (TIME)	DELAY TIME	0-800 [mSEC]	Determines the delay time. (Set in 10-msec steps.)
B (FINE)	TIME FINE	0.0-9.9 [mSEC]	Determines the delay time. (Set in 0.1-msec steps.)
C (FBAK)	FEED BACK	-99-99	Determines the feedback amount.
D (DAMP)	HIGH DAMP	0-99	Adjustment of the high range frequency elements of feedback. A softer sound can be obtained by setting the parameter to high values. It is also useful in simulating the effect of tape echo machines.
F (EBAL)	EFFECT BALANCE	0-100	Determines the balance of the direct sound and the effect sound. The larger the value of this parameter, the louder the effect sound becomes.

EFFECT PARAMETERS

◆ STEREO DELAY GROUP [SDLY, XDLY]

This stereo delay effect is composed of two separate delay circuits.
All parameters other than delay time and feedback have the same left- and right-channel values.

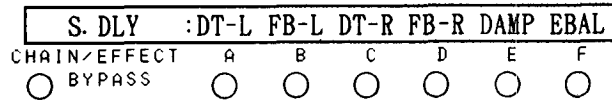

○ Variations

STEREO DELAY [S DLY]: Stereo delay of a dual delay system with parallel feedback (each delay signal feeds back on itself).

CROSS DELAY [X DLY]: Cross delay of a dual delay system with cross feedback (each delay's signal is fed back to the other delay circuit).

○ Parameters

A (DT-L)	DELAY TIME L	0-400 [mSEC]	Determines the delay time of the left channel.
B (FB-L)	FEED BACK L	-99- +99	Determines the degree of feedback in the left channel.
C (DT-R)	DELAY TIME R	0-400	Determines the delay time of the right channel.
D (FB-R)	FEED BACK R	-99- +99	Determines the degree of feedback in the right channel.
E (DAMP)	HIGH DAMP	0-99	Cuts the high frequency in the feedback path. A softer sound can be obtained by setting the parameter to high values.
F (EBAL)	EFFECT BALANCE	0-100	Determines the balance of the direct sound and the effect sound. The larger the value of this parameter, the louder the effect sound becomes.

EFFECT PARAMETERS

◆ MODULATION DELAY GROUP [MDL1, MDL2]

These are two modulation effects that can drastically alter the character of the original sound. This effect allows the use of positive or negative feedback for the creation of unique effects.

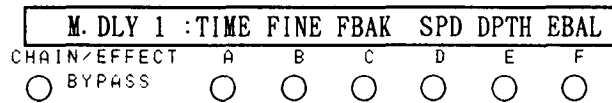

○ Variations

MODULATION DELAY 1 [MDL1]: Delay in which the LFO wave is a sine wave.

MODULATION DELAY 2 [MDL2]: Delay in which the LFO wave is a triangle wave.

○ Parameters

A (TIME)	DELAY TIME	0-500 [mSEC]	Determines the delay time.
B (FINE)	TIME FINE	0.0-9.9 [mSEC]	Determines the delay time. (Set in 0.1-msec steps.)
C (FBAK)	FEED BACK	-99- +99	Determines the amount of feedback. The larger the absolute value of this parameter, the more metallic the sound becomes.
D (SPD)	SPEED	0.05-10.0 [Hz]	Determines the modulation speed.
E (DPTH)	DEPTH	0-100	Determines the modulation depth.
F (EBAL)	EFFECT BALANCE	0-100	Determines the balance of the direct sound and the effect sound. The larger the value of this parameter, the louder the effect sound becomes.

EFFECT PARAMETERS

◆ MODULATION GROUP [CHO1, CHO2, FLN1, FLN2]

This effect combines two chorus/flanger circuits in a stereo configuration. A swirling, constantly changing sound that moves between the stereo outputs is created through phase inversion of the LFOs of the two circuits.

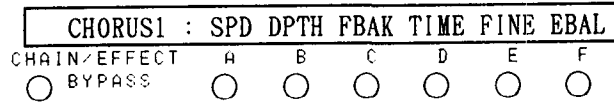

○ Variations

- STEREO CHORUS 1 [CHO1]: Stereo chorus in which the modulation waveform is a sine wave.
- STEREO CHORUS 2 [CHO2]: Stereo chorus in which the modulation waveform is a triangle wave.
- STEREO FLANGER 1 [FLN 1]: Stereo flanger in which the modulation waveform is a sine wave.
- STEREO FLANGER 2 [FLN 2]: Stereo flanger in which the modulation waveform is a triangle wave.

○ Parameters

A (SPD)	SPEED	0.05–10.0 [Hz]	Determines the modulation speed.
B (DPTH)	DEPTH	0–100	Determines the modulation depth.
C (FBAK)	FEED BACK	-99– +99	Determines the degree of feedback.
D (TIME)	DELAY TIME	0–50 [mSEC]	Determines the time before the modulation effect starts following the direct sound. (Set in 1-msec steps.)
E (FINE)	TIME FINE	0.0–0.9 [mSEC]	Determines the delay time. (Set in 0.1-msec steps.)
F (EBAL)	EFFECT BALANCE	0–100	Determines the balance of the direct sound and the effect sound. The larger the value of this parameter, the louder the effect sound becomes.

EFFECT PARAMETERS

◆ PHASER GROUP [PHA1, PHA2]

This effect creates a swirling and swishing sound by phase inversion of the input signals.

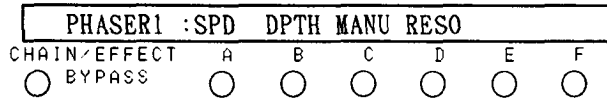

○ Variations

PHASER 1 [PHA1] : Phaser in which the modulation waveform is a sine wave.

PHASER 2 [PHA2] : Phaser in which the modulation waveform is a triangle wave.

○ Parameters

A (SPD)	SPEED	0.05-10 [Hz]	Determines the modulation speed
B (DPTH)	DEPTH	0-100	Determines the depth of the phaser effect.
C (MANU)	MANUAL	0-100	Determines the center frequency that the phaser affects.
D (RESO)	RESONANCE	0-99	Adds feedback to the phaser effect.

EFFECT PARAMETERS

◆ PAN GROUP [PAN1, PAN2]

This effect takes a mono signal and swings it between the left and right outputs for an automatic panning effect.

	A. PAN 1	:SPD	DPTH		
CHAIN/EFFECT	A	B	C	D	E
<input type="radio"/> BYPASS	<input type="radio"/>	<input type="radio"/>	<input type="radio"/>	<input type="radio"/>	<input type="radio"/>

○ Variations

PAN 1 [PAN1] : PAN in which the modulation waveform is a sine wave.

PAN 2 [PAN2] : PAN in which the modulation waveform is a triangle wave.

○ Parameters

A (SPD)	SPEED	0.05–10.0 [Hz]	Determines the speed of the AUTO PAN effect.
B (DPTH)	DEPTH	0–100	Determines the depth of the AUTO PAN effect.

◆ PARAMETRIC EQUALIZER [PEQ]

This effect provides a low and mid range parametric type equalizer.

	P. EQ	:L-Fc	GAIN	M-Fc	GAIN	Q
CHAIN/EFFECT	A	B	C	D	E	F
<input type="radio"/> BYPASS	<input type="radio"/>	<input type="radio"/>	<input type="radio"/>	<input type="radio"/>	<input type="radio"/>	<input type="radio"/>

○ Parameters

A (L-Fc)	Low-Fc	0.1–2 [KHz]	Determines the cutoff frequency of the low frequency range.
B (GAIN)	Low-GAIN	-12– +12 [dB]	Determines the gain of the low frequency range.
C (M-Fc)	Mid-Fc	0.55–8 [KHz]	Determines the cutoff frequency of the mid frequency range.
D (GAIN)	Mid-GAIN	-12– +12 [dB]	Determines the gain of the mid frequency range.
E (Q)	Q	2.0–10.0	Determines the range over which the amount of boost or cut affects. The larger the value, the smaller the effective range.

EFFECT PARAMETERS

◆ PITCH SHIFTER GROUP [PTCH]

This effect allows you to change the pitch of the sound.

	PITCH S : PTCH	EBAL
CHAIN/EFFECT	A B C D E	F
<input type="radio"/> BYPASS	<input type="radio"/> <input type="radio"/> <input type="radio"/> <input type="radio"/> <input type="radio"/>	<input type="radio"/>

○ Parameters

A (PTCH)	PITCH	-100-100 [CENT]	Determines the fine tuning of the sound within a range of ±100 cents. (100 cents = 1 half step)
F (EBAL)	EFFECT BALANCE	0-100	Determines the balance of the direct sound and the effect sound. The larger the value of this parameter, the louder the effect sound becomes.

◆ EXCITER GROUP [XCIT]

This effect gives greater clarity, definition and presence to the sound.

	EXCITER : BLND FREQ	
CHAIN/EFFECT	A B C D E	F
<input type="radio"/> BYPASS	<input type="radio"/> <input type="radio"/> <input type="radio"/> <input type="radio"/> <input type="radio"/>	<input type="radio"/>

○ Parameters

A (BLND)	BLEND	-100-100	Determines the depth of the exciter effect. The larger the absolute value, the greater the degree of the effect. (Different effects can be obtained by positive or negative settings.)
B (FREQ)	FREQUENCY	1.9-18.6 [KHz]	Determines the central frequency that the exciter affects.

EFFECT PARAMETERS

◆ ENSEMBLE GROUP [ENS]

This is a stronger and more pronounced version of the chorus effect.

ENSEMBLE:SPD		DPTH PreD				EBAL
CHAIN/EFFECT	A	B	C	D	E	F
<input type="radio"/> BYPASS	<input type="radio"/>	<input type="radio"/>	<input type="radio"/>	<input type="radio"/>	<input type="radio"/>	<input type="radio"/>

○ Parameters

A (SPD)	SPEED	0.05-10.0	Determines the speed of the ensemble effect.
B (DPTH)	DEPTH	0-100	Determines the depth of the ensemble effect.
C (PreD)	PRE DELAY	0-50 [mSEC]	Determines the time from the direct sound to the effect sound.
F (EBAL)	EFFECT BALANCE	0-100	Determines the balance of the direct sound and the effect sound. The larger the value of this parameter, the louder the effect sound becomes.

◆ ROTARY SPEAKER GROUP [R.SP]

This reproduces the popular rotary speaker effect.

R. SPK		:DPTH RATO SEL				
CHAIN/EFFECT	A	B	C	D	E	F
<input type="radio"/> BYPASS	<input type="radio"/>	<input type="radio"/>	<input type="radio"/>	<input type="radio"/>	<input type="radio"/>	<input type="radio"/>

○ Parameters

A (DPTH)	DEPTH	0-99	Determines the depth of the rotary speaker effect.
B (RATO)	SPEED RATIO	-10-10	Determines the apparent speed ratio of the high frequency range speaker's rotation to the rotation of the low frequency range speaker.
C (SEL)	SPEED SELECT	HIGH/LOW	Determines the rotation speed: high or low.

○ One very important key to using this rotary speaker effect to the greatest advantage is to change the speed in real time, while playing. The three following methods can be used to change the speed in real time.

- 1) When using only the A3
Change by rotating the volume of C (SPEED SELECT) in the Parameter Edit Mode.
- 2) When using the FC6
Press down the switch corresponding to the LED which is lit up in red when using the FC6 in its program selection condition (manual 1, mode 1).
- 3) When using external MIDI instruments.
Transmit data through MIDI over the same program number as being currently used by the A3.

EFFECT PARAMETERS

◆ 3 BAND EQUALIZER GROUP [EQ]

EQ	:L-Fc	GAIN	M-Fc	GAIN	H-Fc	GAIN
CHAIN/EFFECT	A	B	C	D	E	F
<input type="radio"/> BYPASS	<input type="radio"/>	<input type="radio"/>	<input type="radio"/>	<input type="radio"/>	<input type="radio"/>	<input type="radio"/>

○ Parameters

A (L-Fc)	Low-Fc	0.1-2 [KHz]	Determines the cutoff frequency of the low frequency range.
B (GAIN)	Low-GAIN	-12-12 [dB]	Determines the gain of the low frequency.
C (M-Fc)	Mid-Fc	0.55-8 [KHz]	Determines the central frequency of the equalizer.
D (GAIN)	Mid-GAIN	-12-12 [dB]	Determines the gain of the central frequency.
E (H-Fc)	High-Fc	1-8 [KHz]	Determines the cutoff frequency of the high frequency range.
F (GAIN)	High-GAIN	-12-12	Determines the gain of the high frequency.

★ Depending on the setting of the 3 BAND EQ, distortion (or clipping) of the output may sometimes occur even when the input indicator's DIGITAL CLIP LED is not lit up. Adjust the signal to cancel the clipping by turning down each individual GAIN parameters.

◆ SPEAKER SIMULATION [SP 1, SP 2, SP3]

This effect that simulates certain characteristics of speakers, such as those of a guitar amplifier.

SP. SIM1	: FAT	BRIT
CHAIN/EFFECT	A	B
<input type="radio"/> BYPASS	<input type="radio"/>	<input type="radio"/>

○ Variations

3 types of speakers (amplifiers) are simulated.

SPEAKER SIMULATION 1 [SP 1]
SPEAKER SIMULATION 2 [SP 2]
SPEAKER SIMULATION 3 [SP 3]

○ Parameters

A (FAT)	FAT	ON/OFF	Middle range sounds are emphasized when set to ON.
B (BRIT)	BRIGHT	ON/OFF	High sounds are emphasized when set to ON.

EFFECT PARAMETERS

◆ PEDAL PAN [PAN]

This effect allows you to determine the stereo position of the sound (panning to right or left) by using the volume pedal.

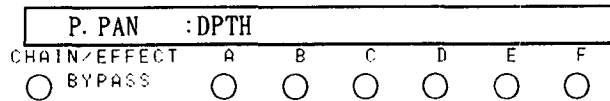

○ Parameters

A (DPTH)	DEPTH	0-100	Determines the depth of the effect of the pedal pan.
--------------------	-------	-------	--

◆ GATE [GATE]

This effect shuts off the output of the sound when the level is lower than a specified setting. A gate reverb effect can be created by using this together with reverb.

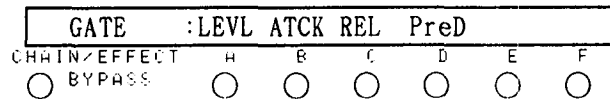

○ Parameters

A (LEVL)	THRESHOLD LEVEL	0-99	Determines the threshold level. The larger the value of this parameter, the higher the threshold becomes.
B (ATCK)	ATTACK TIME	0-99	Determines the time that elapses from when the gate starts to open to when the gate is completely open.
C (REL)	RELEASE TIME	0-99	Determines the time that elapses from when the gate starts to close to when the output level reaches zero.
D (PreD)	PRE DELAY	0-50 [mSEC]	Determines the delay time of the direct sound. When set to a large value, the gate seems to open before the signal level reaches the threshold level.

EFFECT PARAMETERS

◆ PEDAL WAH [WAH]

As indicated by the name, a wah-wah effect can be controlled in real time by operating a volume pedal. Setting is either on or off. There are no variations or parameters.

P. WAH	:	NO PARAMETER!				
CHAIN/EFFECT	A	B	C	D	E	F
<input type="radio"/> BYPASS	<input type="radio"/>	<input type="radio"/>	<input type="radio"/>	<input type="radio"/>	<input type="radio"/>	<input type="radio"/>

◆ EARLY REFLECTION [ER 1/ER 2/ER 3]

E. REF 1	:	TIME	PreD	L. EQ	H. EQ	EBAL
CHAIN/EFFECT	A	B	C	D	E	F
<input type="radio"/> BYPASS	<input type="radio"/>	<input type="radio"/>	<input type="radio"/>	<input type="radio"/>	<input type="radio"/>	<input type="radio"/>

○ Variations

EARLY REFLECTION 1 [ER 1] : Gate reverb effect.

EARLY REFLECTION 2 [ER 2] : Gate reverb effect.

EARLY REFLECTION 3 [ER 3] : An effect like that of a tape being played in reverse.

○ Parameters

[A] (TIME)	E.R. TIME	5-500 [mSEC]	Determines the early reflection time
[B] (PreD)	Pre DELAY	0-100 [mSEC]	Determines the time that elapses from the onset of the direct sound to that of the early reflection sound.
[C] (L. EQ)	Low EQ	-12- +12 [dB]	Determines the gain which cuts or boosts the low range frequencies.
[D] (H. EQ)	High EQ	-12- +12 [dB]	Determines the gain which cuts or boosts the high range frequencies.
[F] (EBAL)	EFFECT BALANCE	0-100	Determines the output level balance of the effect sound and the direct sound.

PERFORMANCE PARAMETERS

The functions of the performance parameters set in the Performance Play mode are covered here. In the Performance Play mode, the representative parameter is selected up from the 6 effects of each chain and displayed. Press DISPLAY SELECT to see to which effect the displayed performance parameter is set. This corresponds to the indication position of the effect name in individual play. For example, in the chart below, SENS in the left indicates the sensitivity parameter of the compressor effect.

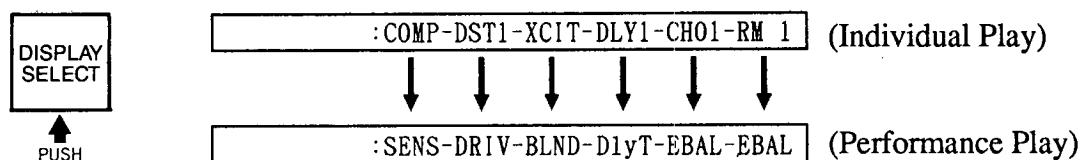

Parameter Name	Display	Functions
SENSITIVITY	SENS	Determines the sensitivity of the compressor.
TONE	TONE	Adjusts the Mid frequency of the equalizer.
DRIVE	DRIV	Determines the distortion of distortion group effects.
BLEND	BLND	Determines the blend (depth of the effect) of the exciter.
DELAY TIME	DlyT	Determines the delay time of delay group effects.
E. R TIME	E. rT	Determines the early reflection time.
SPEED	SPD	Determines the speed of the effects which have SPEED parameters.
DEPTH	DPTH	Determines the depth of the effect which have DEPTH parameters.
EFFECT BALANCE	EBAL	Determines the effect balance of the effect which have EBAL parameters.
PITCH	PTCH	Determines the pitch of the pitch shifter.
THRESHOLD LEVEL	THR	Determines the threshold level of the gate.

UTILITY

The following five functions make up the Utility mode.

- (1) **Name**
Naming of programs.
- (2) **Level**
Sets the master volume setting of each program and the threshold level of the internal noise gate for each program.
- (3) **Pedal/switch**
Assigning functions to the Pedal/SW 1,2 jacks on the rear panel.
- (4) **Card**
Loading data from optional ROM/RAM cards to internal memory and saving internal data to RAM cards.
- (5) **MIDI**
Selects the MIDI channels, OMNI ON/OFF and allows loading and saving data via MIDI Exclusive message.

Determines Up:

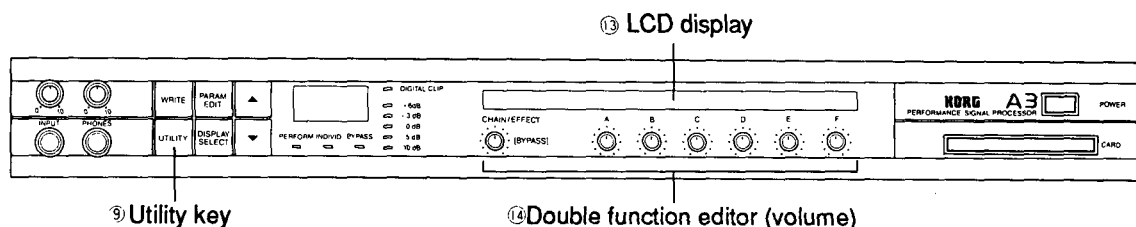

Press the UTILITY key (9); its LED will light up. The Utility mode can be selected directly from any condition (except while the Write operation is being executed). To return to the previous operation or mode, press the UTILITY key (9) again; the LED on the switch will go off. The LCD display (13) shown below will appear when you have entered the Utility mode.

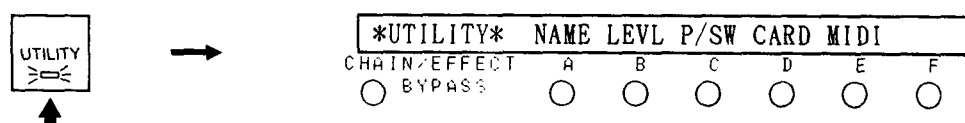

Press the double function editor (14) under the parameter you wish to edit.

(1) NAME

Before entering the Utility mode, select the program to be named by using the UP/DOWN keys. After you have selected Name in the Utility mode, the following LCD display (13) will appear and the program can be named with a maximum of 7 characters.

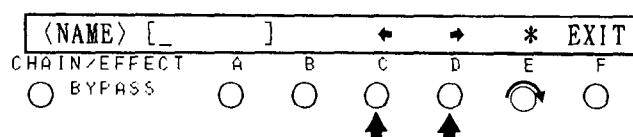

UTILITY

Move the cursor between characters on the name by pressing the C (←) and D (→) double function editors. Then select the characters you wish to use by rotating the E double function editor. Step-by-step selection of characters can be done by using the UP/DOWN keys (5). Press F (EXIT) or the UTILITY key (9) after entering the name to automatically write the name to memory. (There is no need to memorize the name with a separate write step.)

!"#\$%&'()*+,-./0123456789:;<=>? @ABCDEFGHIJKLMNPOQRSTUVWXYZ[\]^_` ~abcdefghijklmnopqrstuvwxyz{ }~
--

The following characters and letters are available:

(2) LEVEL

Before entering the Utility mode, select the program for which you wish to change the level. After you have selected Level in the Utility mode, the following LCD display will appear.

<LEVEL>	VOL = 10	THR = 0	EXIT			
CHAIN/EFFECT	A	B	C	D	E	F
<input type="radio"/> BYPASS	<input type="radio"/>	<input checked="" type="radio"/>	<input type="radio"/>	<input checked="" type="radio"/>	<input type="radio"/>	<input type="radio"/>

- The master volume of the selected program can be set by rotating the B double function editor. (Range = 0 - 10)
- The threshold level of the internal noise reduction can be set by rotating the D double function editor. (Range = 0 - 10)
- Press the double function editor directly below EXIT in the display to return to the initial Utility mode display.

★ About the Noise Reduction Function:

The A3 is equipped with a digital noise gate that shuts down the output when the input signal level reaches a point below a specified level. The level at which this noise gate function is triggered is called the threshold level. The threshold level should be set to a high value when the noise level is high.

(3) Pedal/Switch (P/SW)

After you have selected Pedal/Switch in the Utility mode, the following LCD display will appear.

<P/SW>	[1]→PRG-U	[2]→PRG-D	EXIT			
CHAIN/EFFECT	A	B	C	D	E	F
<input type="radio"/> BYPASS	<input type="radio"/>	<input type="radio"/>	<input type="radio"/>	<input type="radio"/>	<input type="radio"/>	<input type="radio"/>
		↑		↑		

When assigning a function to pedal switch 1, press the B double function editor. Likewise, to assign a function to pedal switch 2, press the D double function editor.

UTILITY

● Functions Controllable with the KORG Volume Pedal KVP-001:

- VOL (volume): The pedal is used to continuously adjust the volume of the effect sound.
- PARAM (PARAMETER CONTROL) : The pedal is used to continuously control the parameters of the effects.
See the CHAIN list included with this manual for the controllable parameters.

● Functions Controllable with Footswitches (such as the KORG PS - 1):

- PROG-U (program up) : Advances the program number by 1.
- PROG-D (program down) : Reverses the program number by 1.
- BYPASS : Switches the bypass function ON/OFF.
- R.SPD (Rotary speaker speed): Change the speed of Rotary speaker.

Press the double function editor directly below EXIT in the display to return to the initial Utility mode display.

(4) CARD

After you have selected CARD in the Utility mode, the following LCD display will appear.

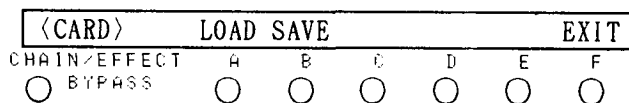

Select either SAVE (for transmitting internal data to the card) or LOAD (for transmitting the data in the card to internal memory) by pressing the "A" or "B" double function editors. Press EXIT to cancel the operation.

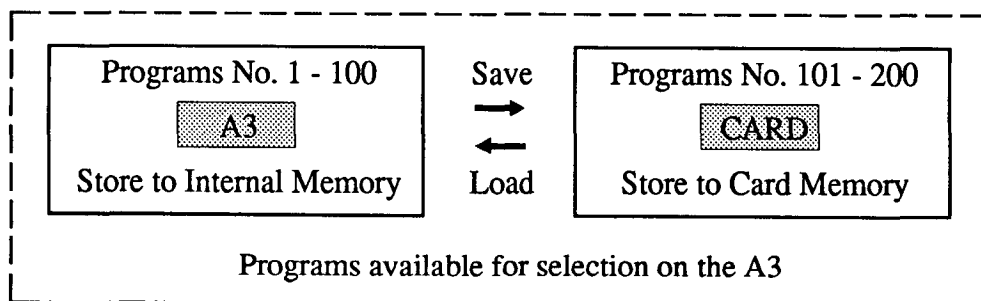

(1) LOAD Operation

- 1) Insert the ROM card or RAM card into the CARD slot.

After selecting the Load function, the following LCD display will appear:

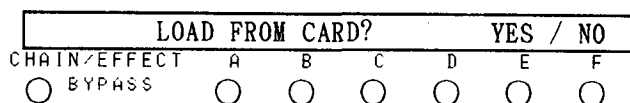

UTILITY

- 2) Loading will begin after you press the double function editor directly below YES. The display will return to the initial Utility mode display when the loading is completed.

The data of the programs No. 101 - 200 in the card will have been transmitted to the programs No. 1 - 100 in the A3.

(2) SAVE Operation

- 1) Take a RAM card whose Protect Switch (the switch found on the upper left of the card) has been turned OFF and insert it into the CARD slot. After selecting the Save function, the following LCD display will appear:

SAVE TO CARD?					YES / NO	
CHAIN/EFFECT	A	B	C	D	E	F
<input type="radio"/> BYPASS	<input type="radio"/>	<input type="radio"/>	<input type="radio"/>	<input type="radio"/>	<input type="radio"/>	<input type="radio"/>

- 2) Saving will begin after you press the double function editor directly below YES. The display will return to the initial Utility mode display when the loading is completed.

The data of the programs No. 1 - 100 in the A3 will have been transmitted to the programs No. 101 - 200 in the card.

(3) How to Format a RAM Card

Before you can use newly purchased RAM cards or RAM cards that have been formatted for use with other types of instruments, you must format them on the A3.

- 1) Insert the RAM card to be formatted in the CARD slot. Set the Write Protect Switch on the upper left of the RAM card to OFF beforehand. Continue the formatting operation even if the display shows "DIFFERENT CARD!" after you've inserted the card.
- 2) Enter the Utility mode and select "CARD" by pressing the D double function editor. The display shown below will appear.

FORMAT THIS CARD?					YES / NO	
CHAIN/EFFECT	A	B	C	D	E	F
<input type="radio"/> BYPASS	<input type="radio"/>	<input type="radio"/>	<input type="radio"/>	<input type="radio"/>	<input type="radio"/>	<input type="radio"/>

- 3) Formatting will be executed after you press the double function editor directly below YES. The display will return to the initial Card selection display when formatting is completed.

★ The program data of No. 1 - 100 can be saved since the data (ID) which indicates that the card can be used with the A3 is written to the card when formatting.

UTILITY

(4) Error Messages

Repeat the relevant instructions again should any of the following error messages appear in the display.

DIFFERENT CARD!

- A ROM card for use on an instrument other than the A3 has been inserted.

NO CARD!

- The Card has not been properly inserted, or has not been inserted at all. Insert the RAM card or ROM card.

WRITE PROTECTED CARD

- The Write Protect Switch of the RAM card is ON. Attempt the Save operation once again after switching the Write Protect to OFF.

ROM CARD!

- Data cannot be saved to a ROM card. Save by using a properly formatted RAM card.

*** DATA ERROR!! ***

- Save or Load has not been correctly executed. Attempt the operation again. The card may possibly be damaged if this message appears repeatedly. When this indication is shown during the formatting operation, either the Protect Switch of the card is ON or the card itself is damaged.

(5) MIDI

After you have selected MIDI in the Utility mode, the following LCD display will appear.

<MIDI>	CH1	OMNI-ON	LOAD	SAVE	EXIT	
CH1N/EFFECT	A	B	C	D	E	F
<input type="radio"/> BYPASS	<input type="radio"/>	<input type="radio"/>	<input type="radio"/>	<input type="radio"/>	<input type="radio"/>	<input type="radio"/>

(1) Determines the MIDI Receive, Transmit Channels and OMNI

To set the MIDI channel, press the A double function editor. The channel number advances by 1 upon each pressing of the double function editor. (Range = 1 - 16) Select the OMNI setting by pressing the C double function editor. It can be set to either ON or OFF.

- ★ Only incoming MIDI data of the selected MIDI channel (set in this function) are received when OMNI is set to OFF.

Press the double function editor directly below EXIT in the display to return to the initial Utility mode display.

UTILITY

(2) Loading by MIDI Exclusive

- 1) Using a MIDI cable, connect the MIDI IN terminal of the A3 to the MIDI OUT terminal of an instrument which has a MIDI data filing function (such as the KORG MIDI RECORDER SQD - 8).

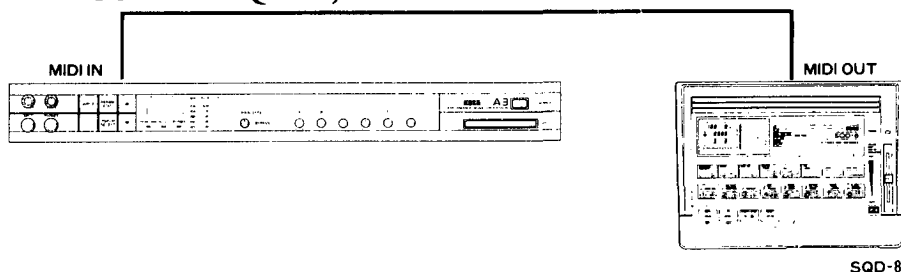

- 2) Select the LOAD function by pressing the D double function editor (in the MIDI functions of the Utility mode). The display below will appear, indicating that loading data via MIDI Exclusive is possible.

LOADING. EXIT

- 3) The Load operation is automatically executed when transmitting data to the A3 from connected external instruments. The display below appears when the operation is completed, and returns to the original MIDI display of the Utility mode after a few seconds.

LOAD COMPLETED

External data are loaded to the A3 programs No. 1 - 100 by the above operation.

★ Concerning Data Error in Loading Operation

- If the following display appears while data is being loaded, there has been some kind of data transmission error. Attempt the operation again. The data files may possibly be damaged if this message appears repeatedly.

*** DATA ERROR!! ***

- If the "LOADING" indication on the display remains, even after transmission from external instruments has apparently been completed, one of the following situations might have occurred:
 - 1) either data was not sent at all, because the MIDI cable was not connected properly, or 2) data that is not compatible with the A3 was sent. It is possible that some programs may be rewritten if erroneous data is received.

(3) Saving by MIDI Exclusive

- 1) Using a MIDI cable, connect the MIDI OUT terminal of the A3 to the MIDI IN terminal of an instrument which has a MIDI data filing function (such as the KORG MIDI RECORDER SQD - 8). (Set the MIDI output switch on the rear panel of the A3 to OUT.)

UTILITY

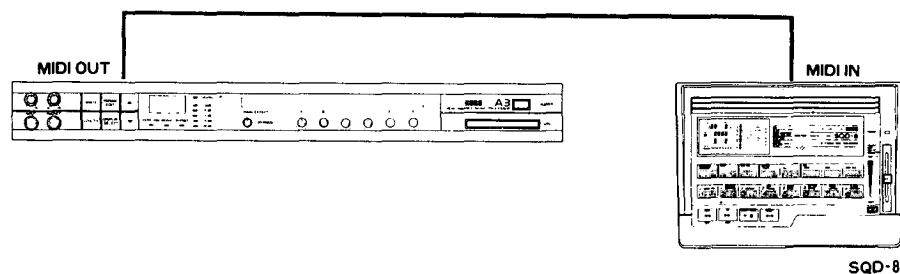

- 2) Make certain that the external instruments are set to receive MIDI data.
- 3) Select "SAVE" by pressing the E double function editor (in the MIDI functions of the Utility mode). The display below will appear, indicating that the saving operation via MIDI Exclusive is being executed.

SAVING.

- 4) The display returns to the original MIDI display of the Utility mode after saving is completed.

OTHER MESSAGES

Messages When Inserting Card

>>> ROM CARD <<<

- A ROM card suitable for use with A3 has been inserted.

>>> RAM CARD <<<

- A RAM card suitable for use with A3 has been inserted.

*** CARD BATTERY LOW ***

- The voltage of the battery in the RAM card is low. Replace the old battery with a new one (lithium battery CR2016). Change batteries while the card is inserted in the card slot of A3.

Message When Turning on the Power

INTERNAL BACKUP BATTERY LOW!

- The voltage of the battery which preserves internal program data is low. Take the A3 to the store where you bought it or nearest service center for battery replacement.

OTHER FUNCTIONS OF THE FC6

The optionally available FC6 Foot Controller is an accessory especially designed to make control of the A3 easier and more convenient. As described on pages 15 and 17, program changes and ON/OFF switching of individual effects of the A3 can be done when connecting the FC6 to the A3. Moreover, many other functions of A3 can be controlled by connecting footswitches or a volume pedal to the FC6.

Setting Up:

Connect footswitches such as the PS-1 or PS-2 to the SW 1, 2 terminals on the rear panel of the FC6 and connect the KVP-001 Volume Pedal to one of the PEDAL 1, 2 terminals. (See the illustration below.)

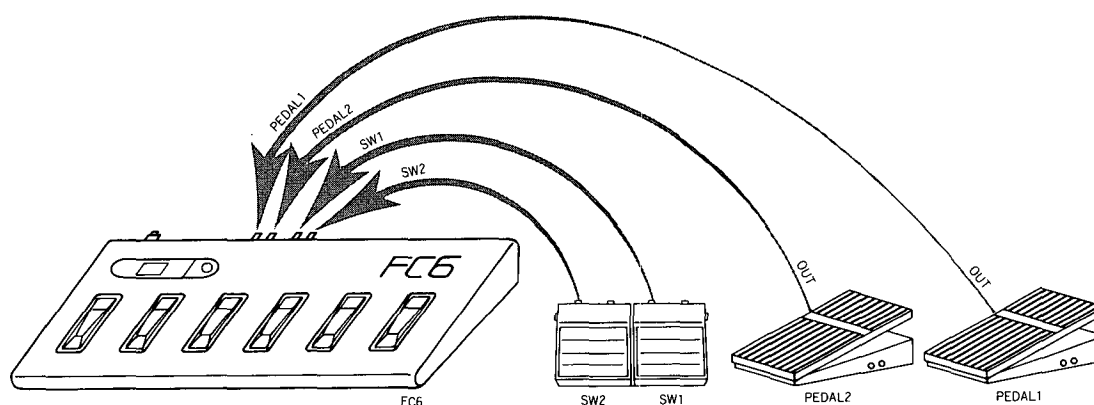

- SW1 : For switching between the modes of the FC6.
- SW2 : For turning the bypass function of the A3 ON/OFF.
- PEDAL 1 : For controlling the volume of the A3.
- PEDAL 2 : For controlling individual effect parameters.
Refer to the chain list included with this manual.
Use of a connected volume pedal allows you to obtain such effects as a pedal-controlled tremolo or chorus modulation speed.

★ Pedals directly connected to the A3 have priority when the Utility mode function Pedal/Switch of the A3 is set to volume or parameter control. Set this function's parameters to something other than "volume" or "parameter" when using PEDAL 1 or 2 of the FC6.

Error Messages on the FC6

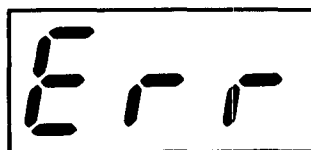

The special cable has not been correctly connected when the LED display of the FC6 appears as shown at right.

APPLICATION EXAMPLES USING THE A3

(1) Guitar Setup (with the FC6)

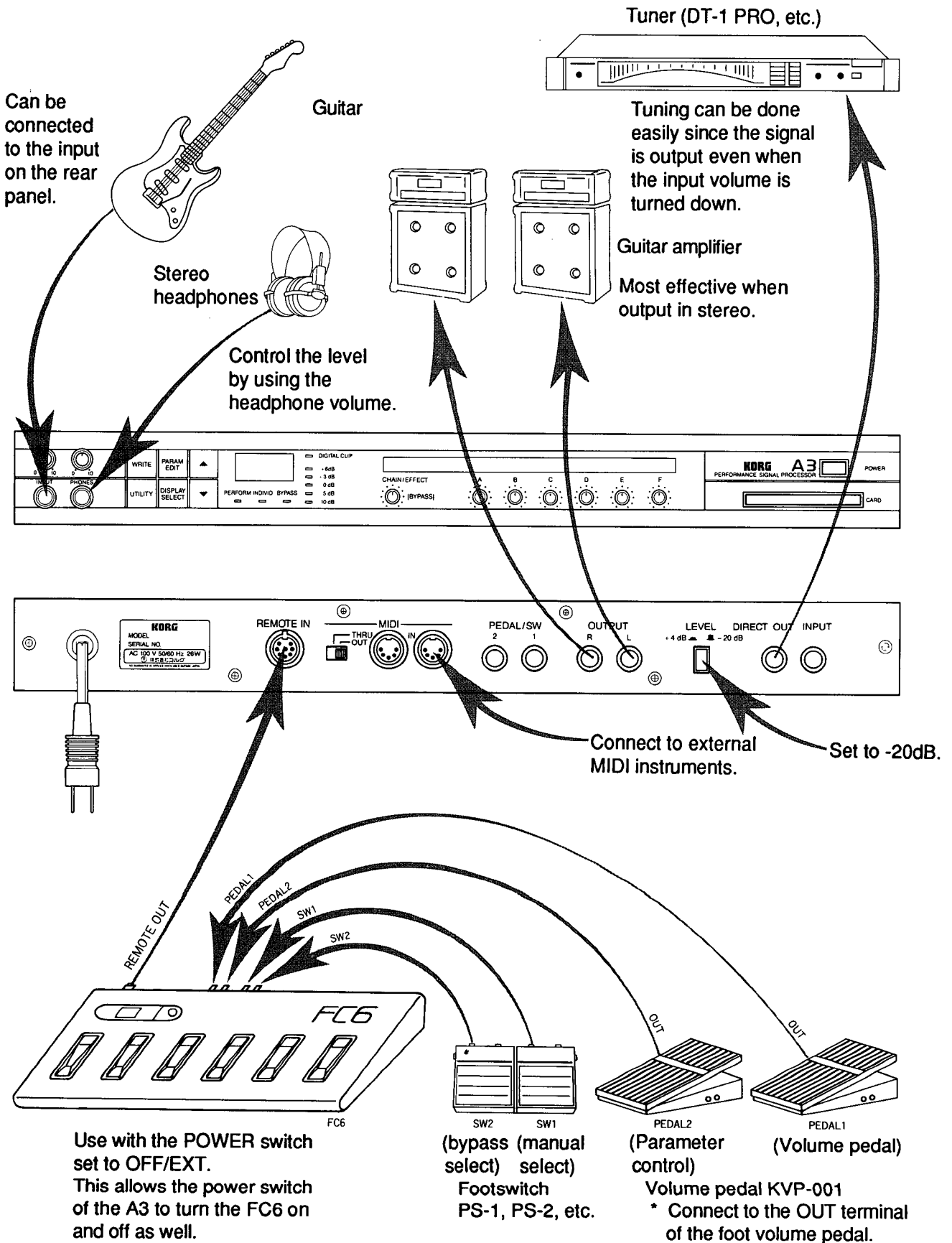

APPLICATION EXAMPLES USING THE A3

(2) Keyboard Setup

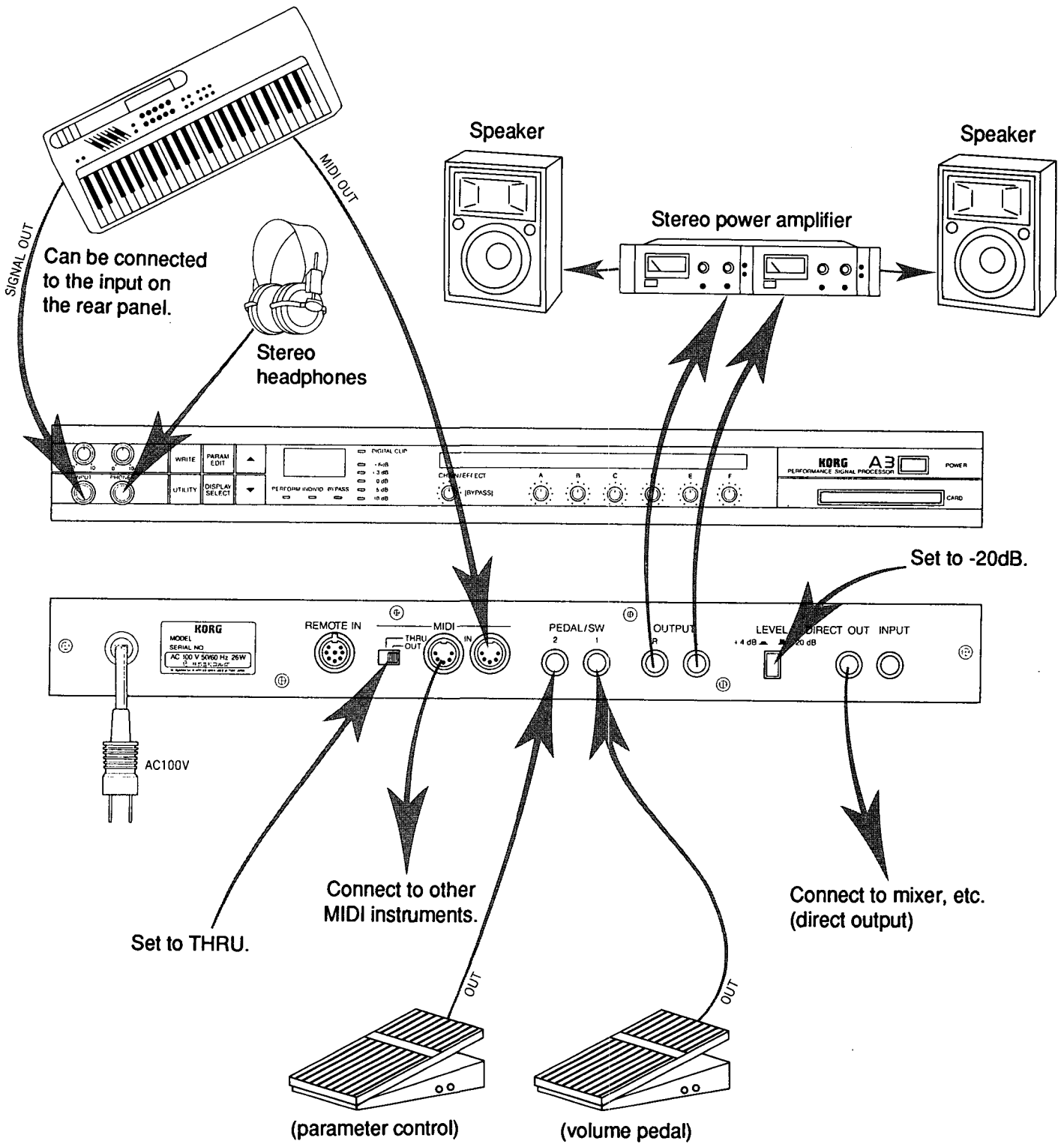

Volume pedal,
EXP-1, EXP-2, etc.
* Refer to page 36 for
setting the pedal/switch.

APPLICATION EXAMPLES USING THE A3

(3) Mixer and Multi-track Recorder Setup

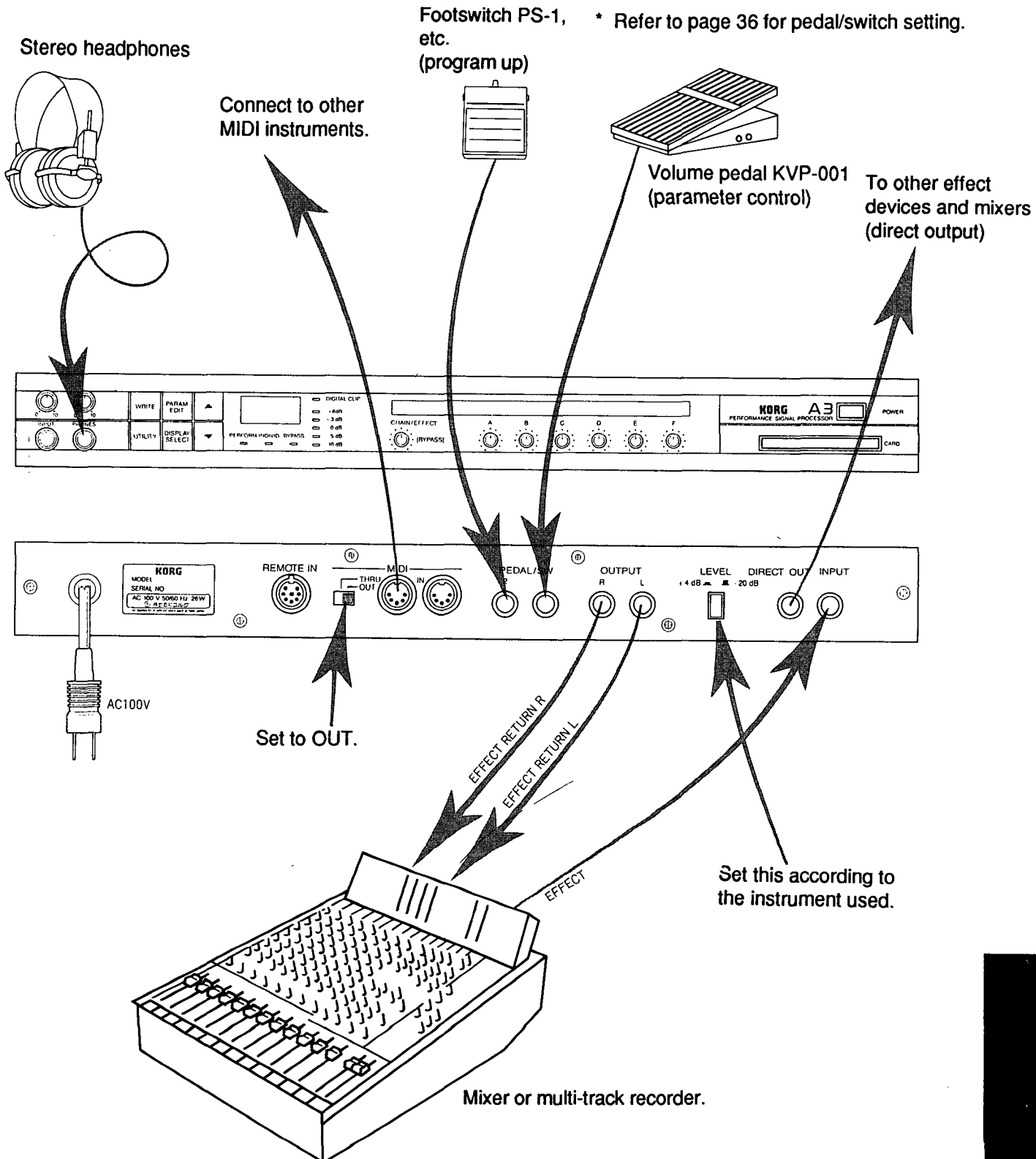

MIDI IMPLEMENTATION

ALL DATA (Program & Chain) DUMP

Byte	Description
F0 42 21 20	EXCLUSIVE HEADER
0100 0000	ALL DATA DUMP
⋮	
0ddd dddd	DATA 29192 byte (6400+8192+4)×2
⋮	
1111 0111	EOX

BANK CHANGE (INT↔CARD)

F0 42 3n 20	EXCLUSIVE HEADER
0100 1110	BANK CHANGE
0001 0010	
0000 000C	BANK DATA (NOTE 1)
1111 0111	EOX

- When receive this message and data, change the Bank.
- When the program is changed between Internal and Card, this message is transmitted.
(NOTE 1) C=0...Internal Program (1~100) C=1...Card Program (101~100)

PROGRAM CHANGE

Status	Second	Description
1100 nnnn	Oppp pppp	nnnn=MIDI CHANNEL(0-15), ppp pppp:PROGRAM NO. (0-99)

RACK MOUNT INSTALLATION

Install according to the instructions below when using a 19-inch rack mount case.

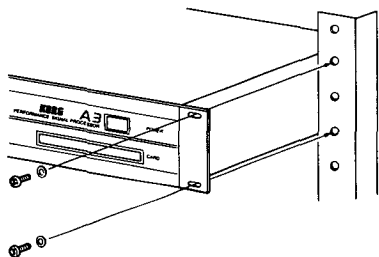

- (1) Install it to the rack with the provided large screws.

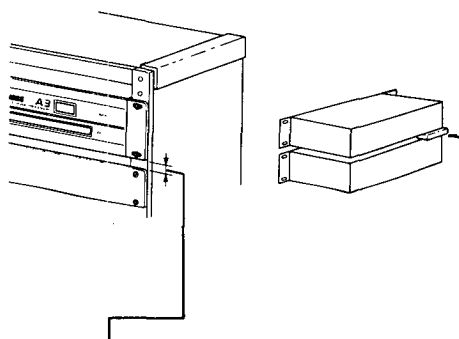

- (2) If there is more than 3 mm of space above or below the A3, you may wish to put packing material in the space to make the installation more stable.

TROUBLESHOOTING

If the following problems develop during normal operation of the A3, follow the suggestions below and check the A3 to spot and remedy the trouble. If the A3 still does not function properly, consult the store at which you bought it or your nearest KORG service center.

(1) No Sound

- Check if the INPUT volume is set to 0. Reset it so that the signal registers on the front panel input indicator LEDs, but not so much that it consistently lights up the DIGITAL CLIP LED.
- It is possible that the Level parameter of one of the effects (Distortion or Compressor in particular) is set to 0. In such a case, the sound will be output only when pressing BYPASS or after resetting the appropriate Level parameters.
- Check if the master volume in the Utility mode is set to 0. If so, reset it to a suitable level.
- If a volume pedal is connected it may be in the up or no sound position.

(2) No Effect

- Check if BYPASS has been turned ON. Press the CHAIN/EFFECT double function editor to turn it OFF.
- Check if the Effect Balance parameter of each effect is set to 0. If so, reset it to a suitable level.
- Check if any effects have been set to OFF. Check that each effect is indicated in capital letters in the Individual Play mode. Effects indicated in lowercase letters have been set to OFF. Press the double function editors (A - F) directly below them to turn them ON.

SPECIFICATIONS AND OPTIONS

- **Input** : Input level/impedance : +4dBm (+19dBm MAX)/1M-ohms,
-20dBm (+19dBm MAX)/1M-ohms
- **Output** : Output level/impedance: +4dBm (19dBmMAX)/600 ohms
-20dBm (-5dBmMAX)/600 ohms
Direct out, Output level/impedance INPUT GAIN UNITY/1K ohms
- **AD/DA** : 16-bit linear (DA: 4-times over-sampling digital filter)
- **Sampling frequency** : 37.1KHz
- **Frequency response** : 24Hz - 18KHz +1.5/-3dB
- **Dynamic range** : 90dB
- **Memory** : No. 1 - 100; No. 1 - 200 when using card
- **Front panel** :
 - KEY SW** : UP, DOWN, DISPLAY SELECT, PARAMETER EDIT, UTILITY, WRITE,
POWER SW, DOUBLE FUNCTION EDITOR [A - F, CHAIN/EFFECT
(BYPASS)]
 - Display** : Backlit LCD character display: 40 characters x 1 row
PROGRAM No. display: 7-segment LED x 3
Dot type LEDs : PERFORMANCE, INDIVIDUAL, BYPASS,
PARAMETER EDIT, UTILITY
 - Input level** : 5-element level meter, and digital clip
 - INPUT VOLUME**
 - PHONES LEVEL**
 - CARD slot**
 - INPUT terminal**
 - PHONES terminal (stereo)**
- **Rear panel**
 - Switches** : Input level toggling switch (-20dB/+4dB)
MIDI OUT/THRU toggling switch
 - INPUT terminal**
 - DIRECT OUT terminal**
 - OUTPUT terminal x 2 (L,R)**
 - PEDAL/SW input terminal x 2**
 - MIDI IN**
 - MIDI OUT/THRU**
 - REMOTE IN**
- **Internal effects**: REVERB GROUP; COMPRESSOR GROUP; DISTORTION GROUP;
DELAY GROUP; STEREO DELAY GROUP;
MODULATION DELAY GROUP; MODULATION GROUP;
PHASER GROUP; PAN GROUP; PITCH SHIFTER GROUP;
EXCITER GROUP; ENSEMBLE GROUP; ROTARY SPEAKER GROUP;
3- BAND EQUALIZER GROUP; SPEAKER SIMULATION GROUP;
PEDAL PAN GROUP; GATE GROUP; PEDAL WAH GROUP;
EARLY REFLECTION GROUP; PARAMETRIC EQ GROUP
- **Power** : AC 100V, 50/60 Hz
- **Power consumption** : 26 W
- **Size (W x D x H)** : 482 mm (W) x 332.5 mm (D) x 44 mm (H) (19" x 12-15/16" x 1-3/4")
- **Weight** : 4.5 kg
- **Optional accessories**: VOLUME PEDAL (KVP-001), FOOT SWITCH (PS-1, PS-2),
REMOTE CABLE (RCC-050, RCC-100),
FOOT CONTROLLER (FC6), RAM CARD (MCR-03),
ROM CARD (SPC-01~)

★ Specifications subject to change without notice.

A 3

MIDI IMPLEMENTATION CHART

Function ...	Transmitted	Recognized	Remarks
Basic Default Channel Changed	1 1~16	1 1~16	
Mode Default Messages Altered	× × *****	MODE 1 × ×	
Note Number : True voice	× ×	× ×	
Velocity Note ON Note OFF	× ×	× ×	
After Touch Key's Ch's	× ×	× ×	
Pitch Bender	×	×	
Control Change	×	×	
Prog Change : True #	0~99 *****	0~127 0~99	*1
System Exclusive	○	○	
System : Song Pos : Song Sel Common : Tune	× × ×	× × ×	
System : Clock Real Time : Command	× ×	× ×	
Aux : LocalON/OFF : All Notes OFF Mes- : Active Sense Sages : Reset	× × × ×	× × × ×	
Notes			
*1 Program number 1~100 is selected for Program change 1~128			

Mode 1 : OMNI ON, POLY
Mode 3 : OMNI OFF, POLY

Mode 2 : OMNI ON, MONO
Mode 4 : OMNI OFF, MONO

○ : Yes
× : No

KORG[®] KORG INC.

15-12, Shimotakaido 1-chome, Suginami-ku, Tokyo, Japan.

1988 © KORG INC.

6401DTH Printed in Japan

®