

SYNTH BASS PROCESSOR

G5

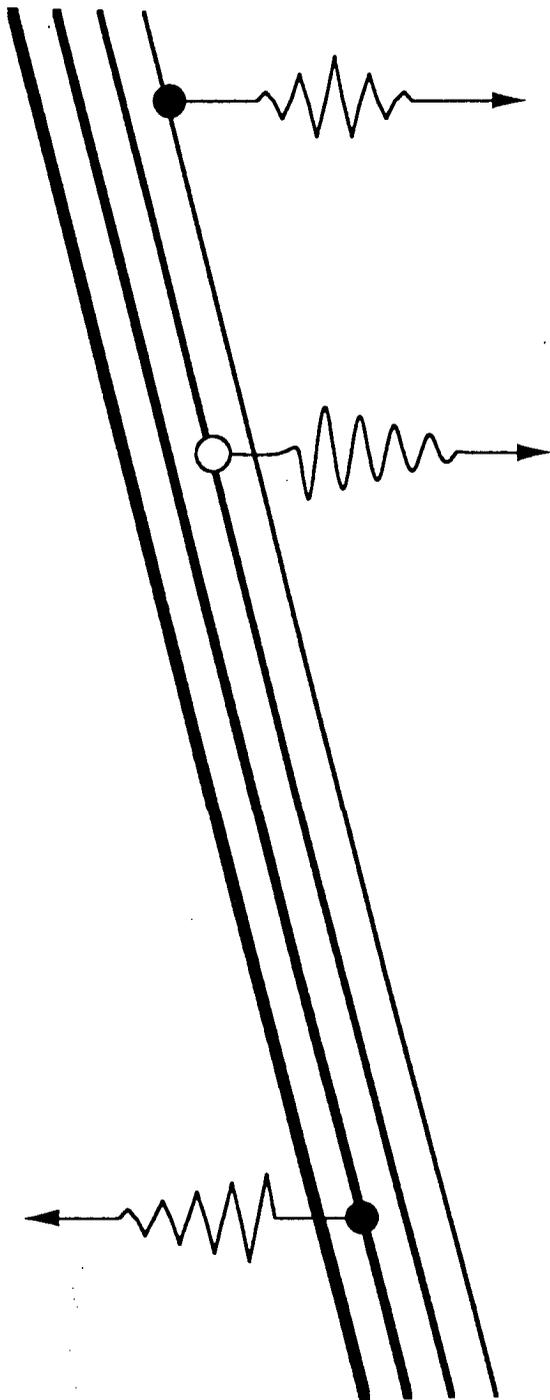

Precautions	1
Front and rear panel	2
Suitable instruments and playing techniques	4
Plug in and start playing!	5
Try out the preset programs	
1. What is a preset program?	6
2. How to select a preset program	7
3. Bypassing the G5	9
4. Muting the G5	10
5. Using the fc pedal	11
Create your own effect	
1. The Parameter Editor	12
WAVEFORM	13
INTENSITY	14
DECAY	14
RESONANCE	15
MIX	15
LEVEL	15
2. Editing procedure	16
3. Viewing the original value	17
4. Compare mode	18
Saving a effect you create (Program Write)	19
Various convenient functions	
1. Parameter editor Lock mode (Compare mode)	21
2. Initializing the program data	22
Troubleshooting	23
Specifications and options	25

TONEWORKS

KORG

Thank you for purchasing the **TONEWORKS**
G5 SYNTH BASS PROCESSOR.



The **G5** is an effect processor for electric bass that combines in one compact body two state-of-the-art digital signal processing modules: a *Wave Shape module* that adds a powerful synth bass sound, and a *Filter module* that sensitively follows every nuance of your playing.



The synth bass sound generated by the *Wave Shape module* is not simply a suboscillator, but radically modifies the sound of the vibrating string itself. The *Filter module* goes beyond analog VCFs, creating incisive crispness and funky resonance effects. These sound processing modules propel the **G5** into a dimension that goes beyond conventional electric bass or synth sounds, bringing you a completely new experience of wild and expressive bass sound.



In order to take full advantage of the **G5's** functions and enjoy long years of trouble-free service, please read this manual carefully, and use the product as directed.

Precautions

■ Location

Avoid using your **G5** in the following locations, which could cause a malfunction.

- Locations subject to direct sunlight
- Locations with extremely high or extremely low temperature or humidity
- Locations with much sand or dust
- Locations that are subject to excessive vibration

■ Power supply

Always use the AC adaptor that comes with the **G5**.

■ Effects on other electrical equipment

The **G5** uses a microcomputer and therefore may cause interference on radios or TVs. If so, move the **G5** away from these devices.

■ Handle gently

Do not apply excess force to the switches and knobs. Doing so can lead to malfunctions.

■ Cleaning

Always clean the outside case with a dry, soft cloth. Never use a liquid solvent, cleaning compounds, highly flammable polishes, or the like.

■ Take care of this user's manual.

Even after you have read this user's manual, store it away carefully for future reference.

THE FCC REGULATION WARNING

This equipment generates and uses radio frequency energy and if not installed and used properly, that is, in strict accordance with the manufacturer's instructions, may cause interference to radio and television reception. It has been type tested and found to comply with the limits for a Class B computing device in accordance with the specifications in Subpart J of Part 15 of FCC Rules, which are designed to provide reasonable protection against such interference in a residential installation. However, there is no guarantee that the interference will not occur in a particular installation. If this equipment does cause interference to radio or television reception, which can be determined by turning the equipment off and on, the user is encouraged to try to correct the interference by one or

more of the following measures:

- Reorient the receiving antenna.
 - Relocate the equipment with respect to the receiver.
 - Move the equipment away from the receiver.
 - Plug the equipment into a different outlet so that equipment and receiver are on different branch circuits
- If necessary, the user should consult the dealer or an experienced radio/television technician for additional suggestions. The user may find the following booklet prepared by the Federal Communications Commission helpful: "How to Identify and Resolve Radio-TV Interference Problems". This booklet is available from the U.S. Government Printing Office, Washington, D.C. 20402. Stock No.004-000-00345-4.

CANADA

THIS DIGITAL APPARATUS DOES NOT EXCEED THE "CLASS B" LIMITS FOR RADIO NOISE EMISSIONS FROM DIGITAL APPARATUS SET OUT IN THE RADIO INTERFERENCE REGULATION OF THE CANADIAN DEPARTMENT OF COMMUNICATIONS.

LE PRESENT APPAREIL NUMERIQUE N'EMET PAS DE BRUITS RADIOELECTRIQUES DEPASSANT LES LIMITERS APPLICABLES AUX APPAREILS NUMERIQUES DE LA "CLASSE B" PRESCRITES DANS LE REGLEMENT SUR LE BROUILLAGE RADIOELECTRIQUE EDICTE PAR LE MINISTERE DES COMMUNICATIONS DU CANADA.

Front and rear panel

Front panel

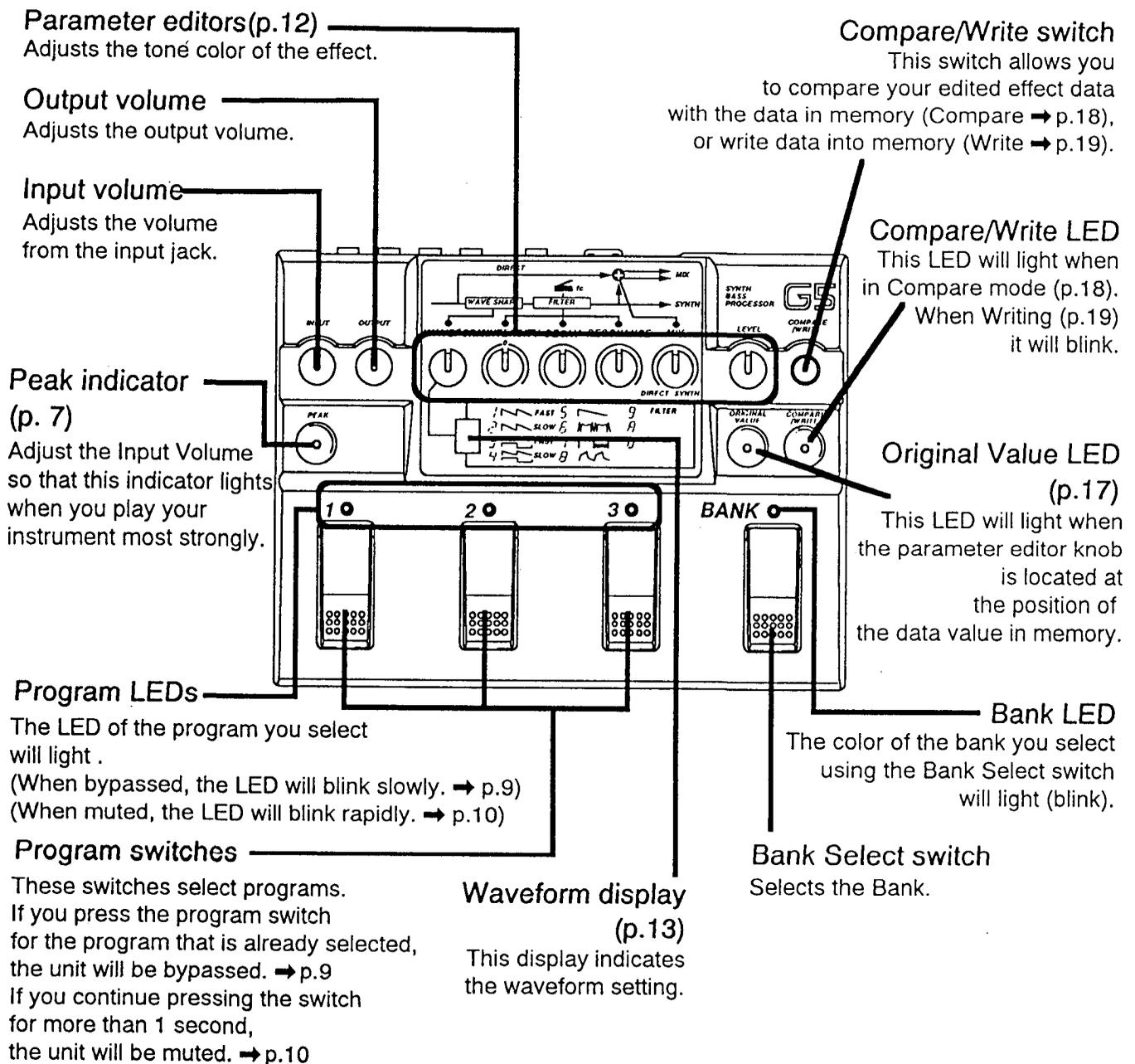

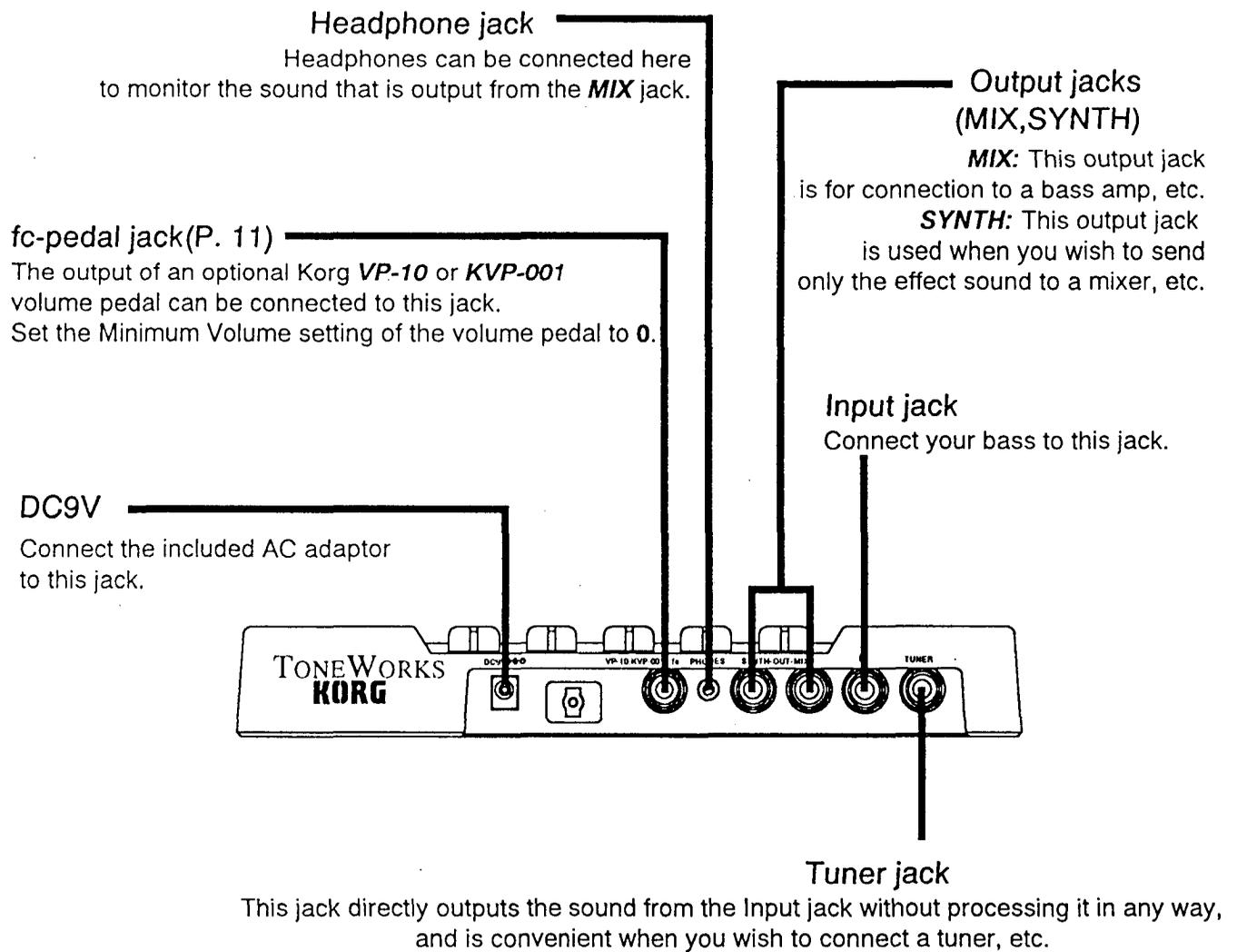

Suitable instruments and playing techniques

Basses suitable for use with the **G5**

The **G5** is designed to work best with conventional four-string basses that are tuned in the conventional way (E. A. D. G).

If you have connected a five-string or six-string bass, be aware that high-position notes on the upper strings (high C, etc.) or low position notes on the low string (low B, etc.) may not function correctly.

Even for conventional four-string basses, tone control settings of the bass itself may prevent the **G5** from operating correctly. In order to take full advantage of the **G5**'s synth bass effects, adjust the tone controls of your bass to get the best effect.

Caution for audio equipment connected to the **G5**

Depending on the settings of the **G5**'s parameter editor or volume, or on the volume and tone settings of the bass connected to the **G5**, *extremely strong oscillations or ultra-low frequency sounds can sometimes be produced*. Some types of amps or speaker may be severely damaged in such cases. Please be careful to use appropriate volume levels so as not to exceed the rated capacity of the equipment that is connected.

Playing techniques and sound

The **G5** does not have its own oscillators, but instead directly process the input sound of the bass itself to create synth bass sounds. This allows the creation of stable yet expressive synth bass sounds that are not possible using an oscillator.

This means that the sustain and decay of the **G5**'s synth sounds will depend on your playing technique on the bass.

Also, when you play a chord into the **G5**'s input, the output will sound muddy. The **G5** is designed for single-note playing.

Plug in and start playing!

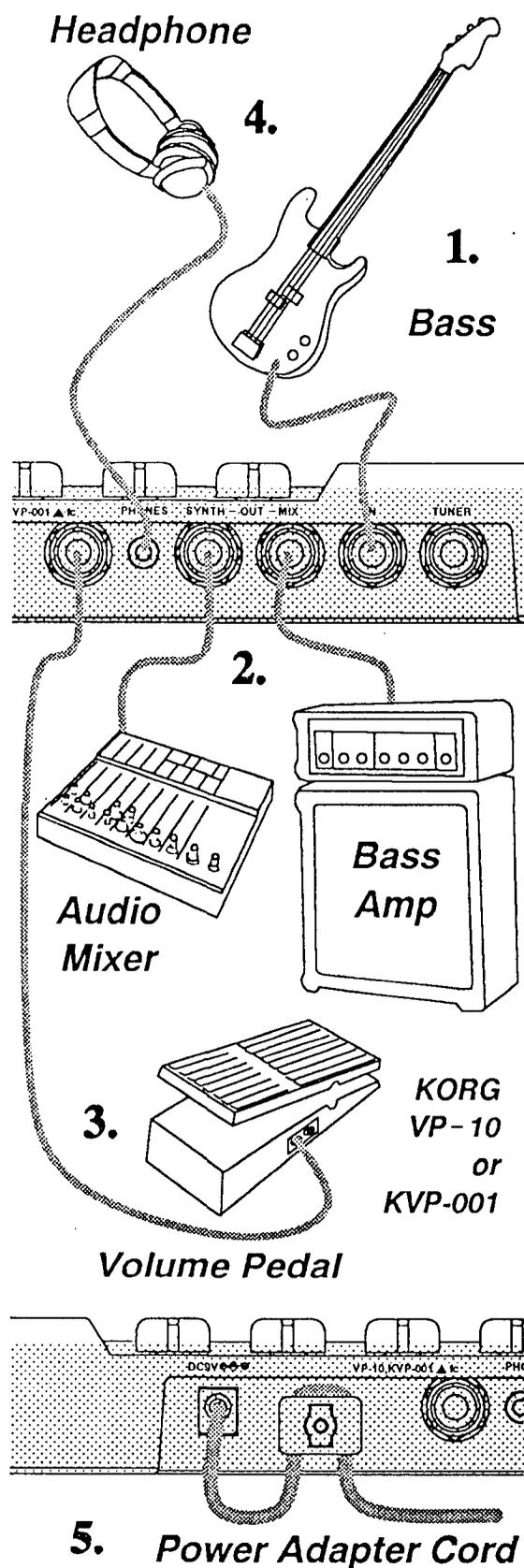

The **G5** has no power switch. It will begin operating when the power adaptor is connected.

Note Place the power adaptor at least 12 inches away from the **G5**. If it is located nearer, electrical interference and noise may occur.

After you connect the power adaptor, hook the power adaptor cord around the provided hook as shown in the illustration, to prevent it from being pulled out accidentally.

Note Before connecting or disconnecting the G5's power adaptor, be sure to turn down the volume on any connected devices.

Try out the preset programs

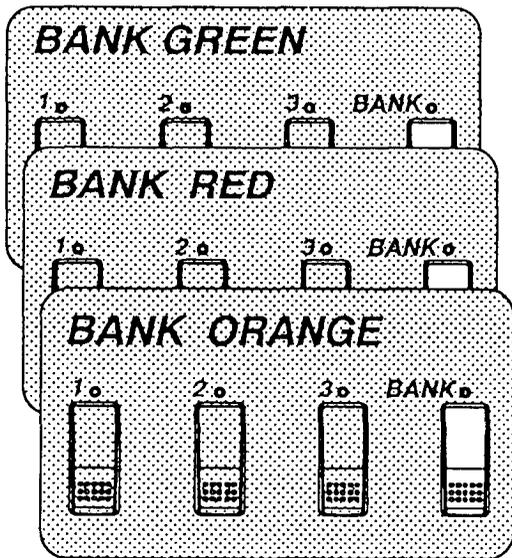

1. What is a Preset Program?

The **G5** has three program banks (green, red and orange), with three effect programs in each bank.

In other words, the **G5** has a total of 9 effect programs that you can select.



The nine programs that are in the **G5**'s memory when you purchase it are called *Preset Programs*.

Each of these programs can be edited (i.e., you can modify them as you like), and the edited programs can be stored as your own programs.



By editing a preset program, you can fine-tune the sound to get just the effect you want. Or, you start with a preset program and create a completely different type of sound.

1.

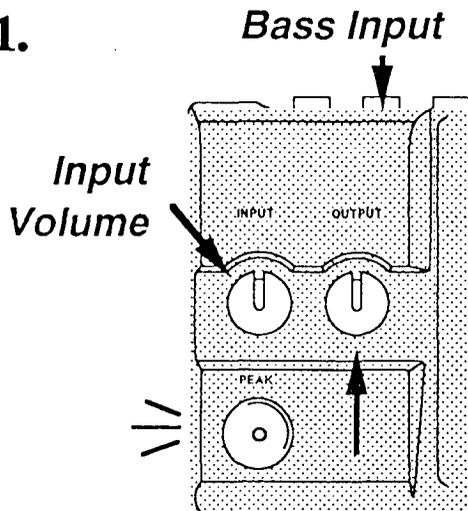

2. Output Volume

3.

Bank Select Switch
blinking red

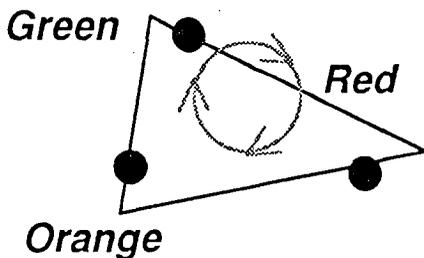
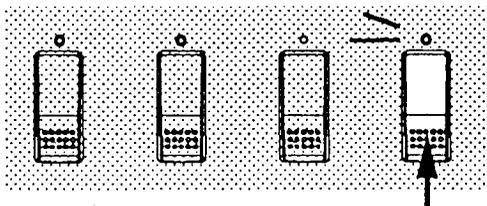

4. Program Switch

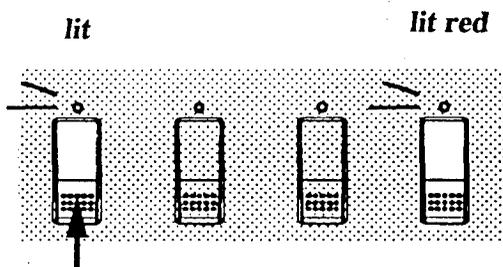

2. How to select a preset program

1. First, adjust the input level as you play your bass.
Adjust the Input Volume so that the peak indicator lights when you play your bass most strongly.

Note Depending on the settings of the Parameter Editor, there may be times when there is unwanted distortion (clipping) in the sound even if the peak indicator is not lighting. In such cases, lower the input volume until the sound no longer distorts.

2. Raise the Output Volume to set the volume.
3. Next, use the Bank Select switch to select the bank. Each time you press the Bank Select switch, you will cycle through banks in the order of:

Green → Red → Orange

As an example, try selecting the Red bank. The bank LED will blink red.

4. Use a Program Switch to select a program. As an example, let's select program 1 of the Red bank.

The program LED of program 1 will light. At the same time, the bank LED will stop blinking, and will remain lit red.

Note When the power is turned on, Green bank program 1 will always be selected.

5. Red bank program 1 is now selected.
Play your bass, and you will hear the effect sound of Red bank program 1.

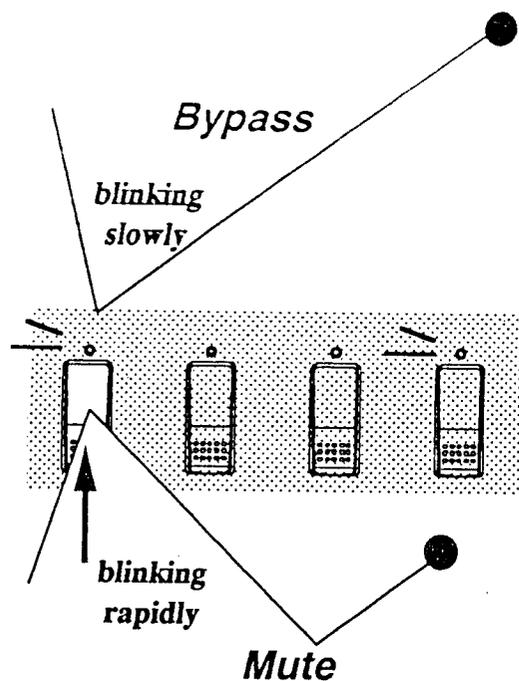

Bank Green Prog. 1

lit green

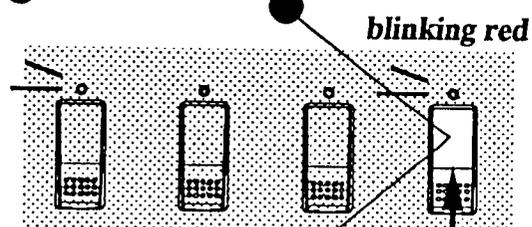
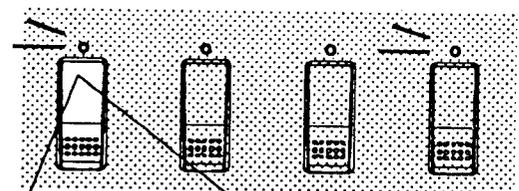

Bank Red Prog. 1

lit red

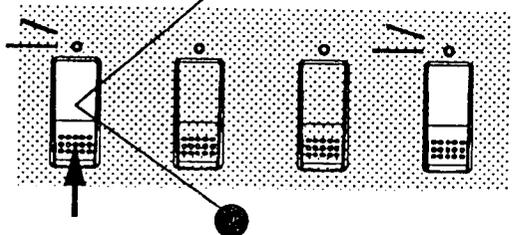

6. If you are using the MIX output and temporarily want to bypass the **G5** (i.e., to hear only the unprocessed sound), press the currently selected program switch once again (in this example, the program 1 switch).

When the **G5** is bypassed, the LED of the selected program will blink slowly.

☞ p.9 Bypassing the **G5**

There may be times, such as when you want to tune during a live performance, that you want to mute the sound temporarily. To mute the sound, press and hold the currently selected program switch for at least 1 second.

When the **G5** is muted, the LED of the selected program will blink rapidly. When you want to hear the sound again, press the program switch once again.

☞ p.10 Muting the **G5**

Note Since the SYNTH jack outputs only the effect sound, turning on Bypass while using the SYNTH jack will mean that there will be no sound at all; the same result as Muting.

7. Repeat from step 3 to try out the programs in the other banks.

If you want to select another program in the same bank, just press a program switch.

Note Simply changing banks does not change the program. The program will change when you press the Program switch.

For example when you want to switch from Green bank program 1 to Red bank program 1, first press the Bank Select switch to switch the bank from green to red, and then press Program switch 1 to select program 1.

3. Bypassing the G5

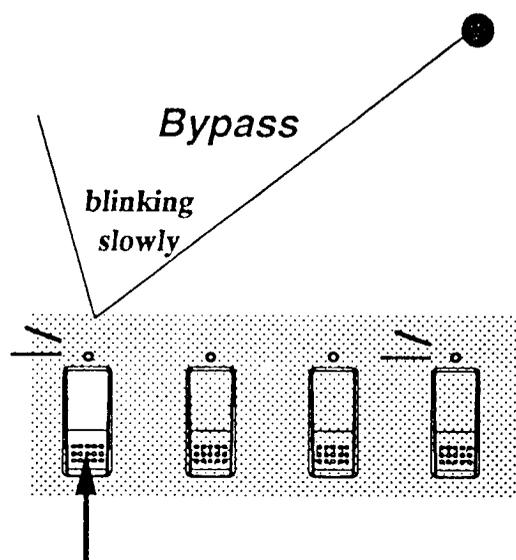

If you press the currently selected Program switch once again, that program LED will begin blinking, and the **G5** will be Bypassed (the unprocessed sound will be output).

To return to the effect sound, press the Program switch once again.

From Bypass, you can also directly select a different program than the currently selected one (the program whose LED is blinking).

For example if Green bank program 1 is selected,

Press program 1

→ the LED of the selected program (program 1) will blink (Bypassed)

☆ Press program 1 again → return to program 1

☆☆ Press program 3 → select program 3

☆☆☆ Press the Bank Select switch to select the Red bank

⇒ press program 1

→ Red bank program 1 is selected

Note While the **G5** is bypassed, editing operations will not affect the sound.

Return to the effect sound before you edit.

4. Muting the G5

There may be times, such as when you want to tune during a live performance, that you want to mute the sound temporarily.

To mute the sound, press and hold the currently selected program switch for at least 1 second.

The LED of the selected program will blink rapidly, and after the bypassed sound and the effect sound alternate briefly, the **G5** will be muted and will no longer output sound.

When you want to hear the effect sound again, press the program switch once again.

In the same way as during Bypass, you can select a program that is different than the currently selected one (the program whose LED is blinking during Muting). → p.9 Bypassing the **G5**

(When muting is turned off, you will return to the effect sound regardless of the state the **G5** was in when you turned on muting. If you enter Mute mode from Bypass mode, you will return to the effect sound, so press the program switch once again to re-enter Bypass mode.)

Note The sound in the headphones will also be muted.

Note As in Bypass mode, editing operations in the Parameter Editor will not affect the sound, so return to the effect sound before you edit.

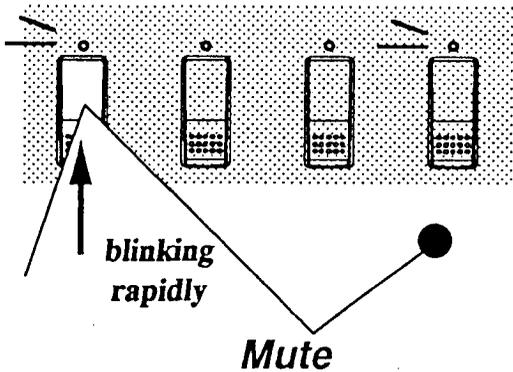

5. Using the fc pedal

The cutoff frequency at which the filter will begin sweeping (the *Start Cutoff frequency: fc*) is normally set automatically according to the **INTENSITY** setting. However if a **fc pedal** is connected, the **fc pedal** movements will control the cutoff frequency.

When the **INTENSITY** parameter editor knob is set to the center position, the cutoff frequency will be controlled only by the pedal, and the pedal can be used similarly to a wah pedal.

If you disconnected the **fc pedal**, the Start Cutoff frequency will once again be automatically set according to the **INTENSITY** value.

The **fc pedal** can be operated even while the **G5** is bypassed or muted. For example if you press the **fc pedal** all the way down (setting the **fc** to the lowest value) while the **G5** is muted or bypassed, the filter will sweep from the lowest frequency when you return to the effect sound.

→ p.9 Bypassing the **G5** / p.10 Muting the **G5**

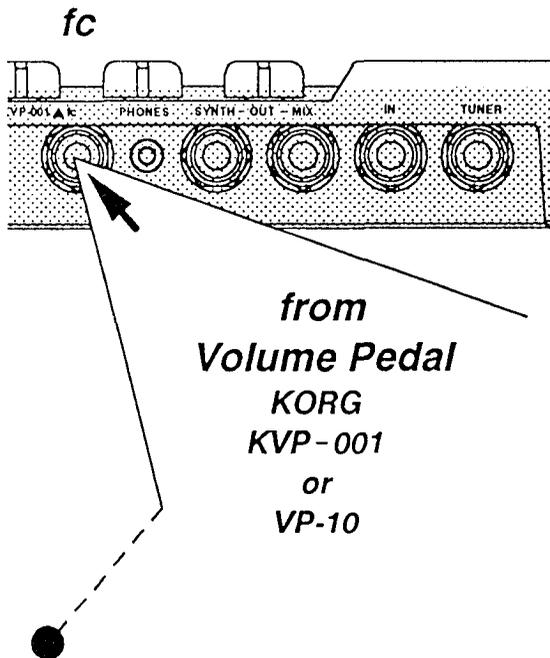

Note If you press down the **fc pedal** (to the lowest position) while the Resonance is extremely high, an ultra-low sound may be output at an extremely loud volume. This can cause sudden overload to the amp/speaker system that is connected, and damage them. Please be careful about making volume settings to avoid overloading the amp/speaker system and other devices that the **G5** is connected to.

Be sure to use only Korg VP-10 or KVP-001 volume pedals as the **fc pedal**.

Connect the output jack (**OUTPUT**) of the volume pedal to the **G5's fc pedal** input jack (**fc**).

Set the **Minimum Volume** control of the volume pedal to 0.

Create your own effect

1. The Parameter Editor

Each of the 9 effect programs in the **G5**'s memory can be modified to create your own original program.

Each of the settings that determine the way an effect program sounds is called a *Parameter*.

By moving the *Parameter Editor* knobs of the **G5** you can easily make your very own synth bass sounds. The process of modifying a program is called *Editing*. Programs that you have edited can be saved in memory for later use.

The **G5** allows you to create your own sounds by making settings as you listen to the results, without having to worry about a large number of complex parameters.

WAVEFORM

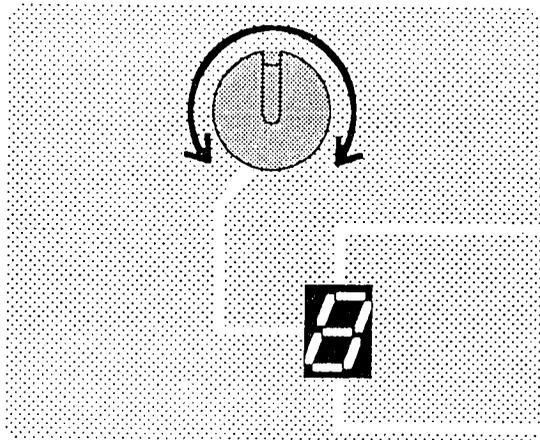

↑
indicates
the waveform setting.

WAVEFORM

..... This parameter selects the waveform of the synth bass.

The choice of waveform processed by the Wave Shape module and the Filter selection give you the following 11 possible variations. Watch the waveform display as you rotate the knob.

1. Sawtooth wave (fast attack)
2. Sawtooth wave (slow attack)
3. Sawtooth wave
+ square wave 1 octave below (fast attack)
4. Sawtooth wave
+ square wave 1 octave below (slow attack)
5. Sawtooth wave 1 octave below
6. Fuzz wave 1
This produces a fuzz sound similar to distortion or an FM synthesizer.
7. Fuzz wave 2
This produces an ultra-low sound with powerful harmonics.
8. Fuzz wave 3
This produces a conventional fuzz sound.
9. Filter (auto wah)
In this variation, the Wave Shape module does not process the bass sound, and only the Filter module will be applied.
- A. Voice filter 1
This produces a sound similar to a Jew's Harp or stretched piece of string.
- b. Voice filter 2
This produces a sound in which the overtones change in complex ways, similar to when a talk box modulator is used.

INTENSITY settings will create other sounds.

INTENSITY

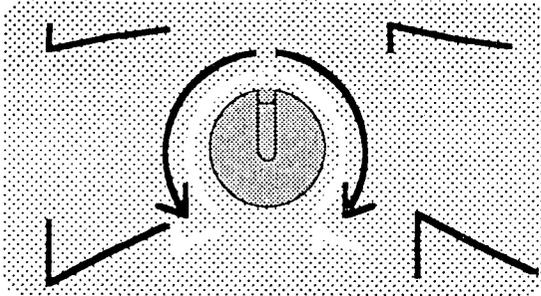

INTENSITY

..... This parameter sets the depth and direction of the filter sweep.

If the knob is rotated to the left, the filter will sweep in the closing direction each time you play. If the knob is rotated to the right, the filter will sweep in the opening direction each time you play.

As the knob is rotated further to left or right, the amount of the filter sweep will increase. If the knob is set to the middle position, the filter will not sweep.

The *Start Cutoff frequency* (f_c) is automatically set according to the direction and depth of the sweep, but by using the f_c pedal, you can control this in realtime.

DECAY

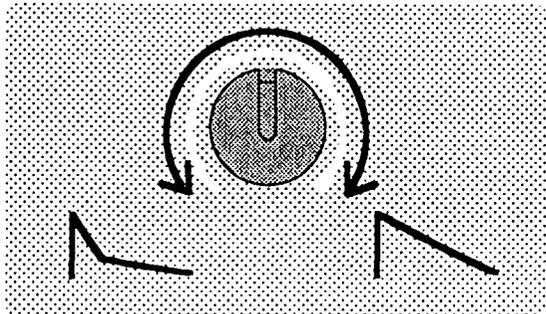

DECAY

..... This parameter adjusts the time over which the filter sweep will return.

As the knob is rotated further to the right, the filter sweep will take longer to return.

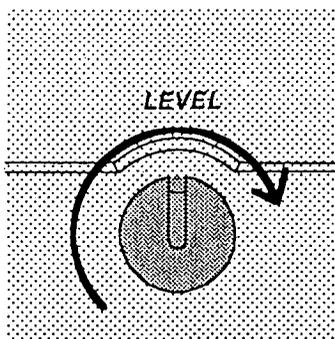
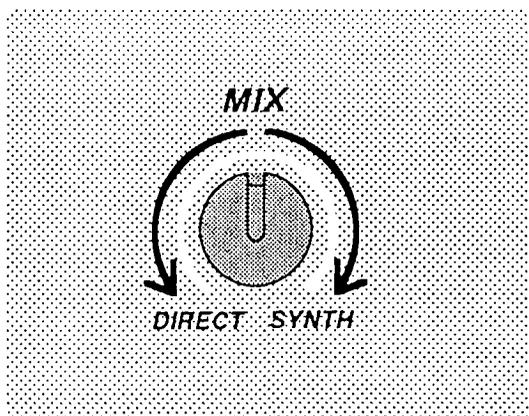
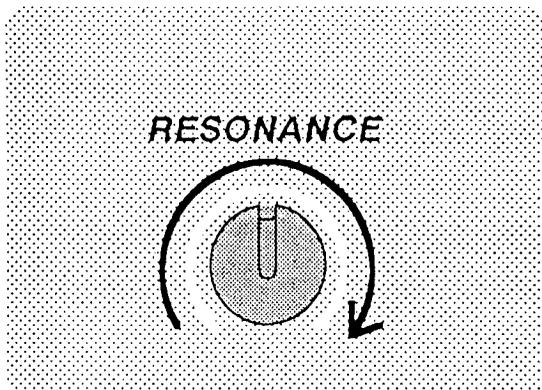

RESONANCE

..... This parameter adjusts the strength of the filter's resonance.

As the knob is rotated further to the right, the filter's resonance will increase, creating a more distinctive sound.

MIX

..... This parameter adjusts the volume balance between the direct sound and the synth bass sound that is output from the MIX jack.

If the knob is rotated all the way to the left, only the direct sound will be heard. If the knob is rotated all the way to the right, only the synth bass sound will be heard. In the middle position, the direct sound and synth bass sound will have approximately equal volumes.

The **SYNTH** jack will output only the synth bass sound, regardless of the setting of this parameter.

LEVEL

..... This parameter adjusts the volume of the program.

As the knob is rotated further to the right, the volume will increase.

Note If you rotate the **MIX** knob all the way towards **DIRECT** (all the way to the left) and set the **LEVEL** knob to a high setting, the volume of the direct output may be even louder than the bypassed volume.

2. Editing procedure

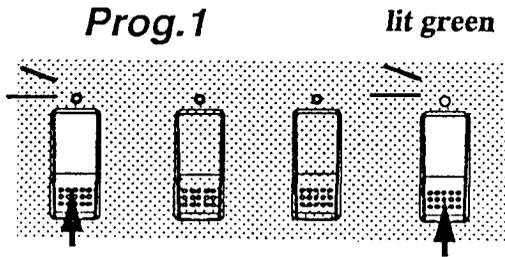

RESONANCE

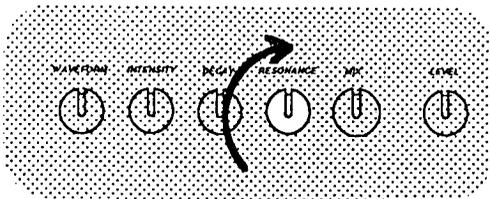

Now try moving the Parameter Editor knobs to modify an effect program to your liking.

1. First select the program you want to start with.

In this example, we will select Green bank program 1.

Be sure that the **G5** is not in Compare mode.

If the Compare/Write LED is lit, the **G5** is in Compare mode. Press the Compare/Write switch once to exit Compare mode.

2. Move the parameter editor knob for the parameter you wish to modify.

In this example, let's modify the **RESONANCE** setting. Adjust the **RESONANCE** knob while you listen to the difference it makes in the sound.

(As you increase the **RESONANCE** setting, the filter's resonance will become stronger, resulting in a more distinctive sound.)

3. In the same way, use the parameter editor knobs to modify other parameters.

→ For details on each parameter, p.13-

4. If you wish to edit another program, use the Bank Select switch and a Program switch to select it.

However if you want to keep the changes you made, you must perform the *Program Write operation*. → p.19

Note If you select another program without performing the Program Write operation, the changes you made when editing will be lost.

3. Viewing the original value

When modifying the 9 preset programs of the **G5** to your own settings, you may sometimes want to know the original settings of each parameter.

As you edit, you can check the original value of a parameter by watching the **Original Value LED**.

When you write an edited program into memory, the settings of the parameter editor are marked, so that you can later check them if desired.

As you rotate each parameter editor knob (WAVEFORM, INTENSITY, DECAY, RESONANCE, MIX, and LEVEL), the Original Value LED will light when the position of the knob matches the setting of the program.

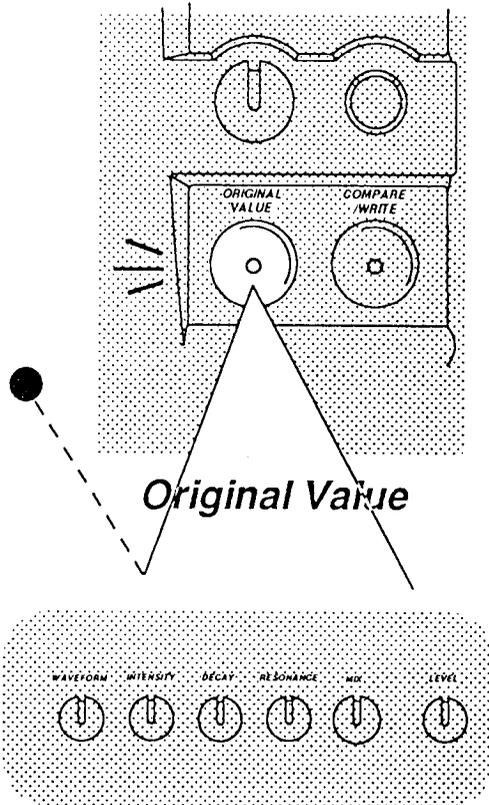

Note When watching the Original Value LED to check the original values in a program, be sure to rotate the parameter editor knob slowly. If you rotate the knob too quickly, the Original Value LED may light too briefly for you to notice.

Note When checking the Original Value LED, the position that the parameter editor knob was in when you executed Program Write may sometimes be slightly different from the position it is in when the Original Value LED lights. However the actual sound at the location where the Original Value LED lights will always match the sound you were hearing when Program Write was executed.

4. Compare mode

To enter Compare mode, press the Compare/Write switch to make the Compare/Write LED light.

The **G5** allows you to use the parameter editor knobs to adjust the sound at any time to create your own effects. As you do so, there may be times when you would like to hear the settings you started with, so that you can hear the difference that your changes have made.

Compare mode allows you to hear the sound of the settings in memory for that program. By pressing the Compare/Write switch, you can alternate between listening to your modified settings and the original settings of the program.

Note Even if you move the parameter editor knobs while in Compare mode, the sound will not change. Exit Compare mode before continuing with your editing. → p.16 Editing procedure

However the fc pedal will still operate in Compare mode, and the position of the fc pedal will be maintained regardless of whether the **G5** is in Edit or Compare mode.

For example if in Compare mode you press down the fc pedal, the sound will be as appropriate for the fc pedal position when you return to Edit mode.

Note If the **G5** is in Bypass or Mute mode, pressing the Compare/Write switch will not enter Compare mode, nor make the Compare/Write LED light.

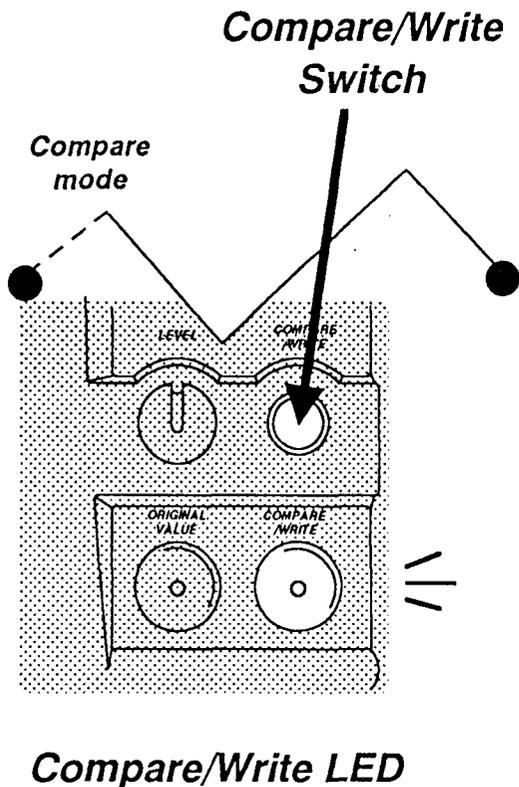

Saving a effect you create (Program Write)

Effect programs you create can be saved into the **G5**'s internal memory. This procedure is called Program Write.

Programs you write into memory can be selected using the Bank Select switch and the Program switches in the same way as for the preset programs.

Unless you write your edited program into memory, it will be lost when you press a different program switch or turn the power off.

When you write your edited settings into a program, the program data that was previously in that location will be lost.

1. When you have finished editing, press and hold the Compare/Write switch for at least 1 second. The Compare/Write LED will begin blinking, indicating that the **G5** is ready for the program to be written into memory.

If you want to write your edited settings into a program or bank different than the original program, use the Bank Select switch and the Program switches to select the writing destination. The LEDs of the selected bank and program will light.

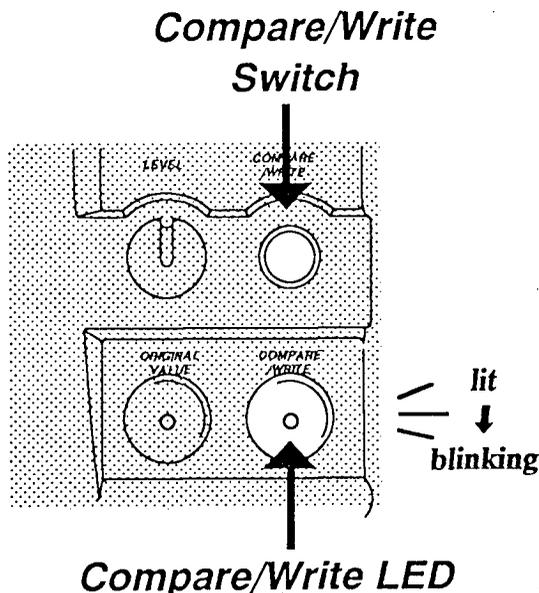

**press the Compare/Write switch
→ the G5 will enter Compare mode**

**continue pressing for at least 1 second
→ the Compare/Write LED
will begin blinking (waiting to Write)**

press the Compare/Write switch
once again
→ edited data will be written

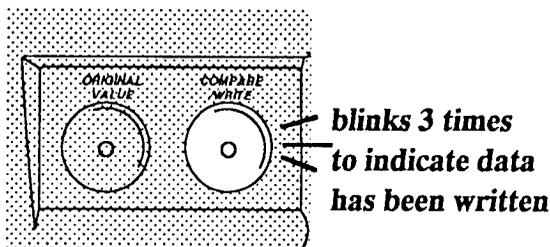

If you decide to cancel the Program Write operation while the **G5** is waiting to Write, simultaneously press any two of the Program or Bank Select switches (any two of the total of four switches). The Compare/Write LED will go out, and you will return to Edit mode.

2. If you are sure you want to write your edited settings into memory, press the Compare/Write switch once again. The Compare/Write LED will blink 3 times, indicating that the edited data has been written into memory.

Note When you press the Compare/Write switch, the **G5** will first enter Compare mode (p.18). This means that if you are playing your instrument at that moment, the sound will briefly change during this process. (The unedited original settings will be heard.) However this has no effect on the settings that are being written.

If you are writing your settings into a bank or program different from the one you started with, select the desired writing destination.

If you are in Compare mode, Compare mode will automatically be cancelled.

Note When you finish editing, be sure not to press a different Program switch before executing the Program Write operation. If you do so, your editing settings will be lost.

Note If the **G5** is bypassed, pressing the Compare/Write switch will not execute the Write operation, nor will the Compare/Write LED light.

Various convenient functions

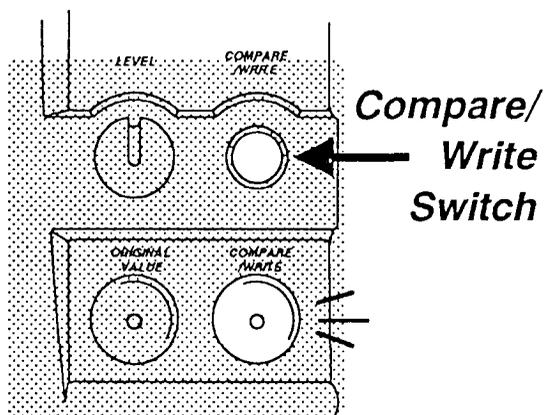

***If you leave the G5 in Compare mode,
the sound will not change
even if the knobs are moved.***

1. Parameter editor Lock mode (Compare mode)

If you want to prevent the effect sound from changing when you accidentally touch the parameter editor knobs, you can leave the **G5** in Compare mode.

Press the Compare/Write switch to make the Compare/Write LED light.

In Compare mode, the sound will not change even if the parameter editor knobs are moved. If the fc pedal is connected, you will still be able to use it to modify the Start Cutoff frequency.

Compare mode was originally designed for the purpose of allowing you to compare the sound of your edits with the original sound, but it can also be used as a parameter editor lock function. In live performances, we recommend that you take advantage of this function.

2. Initializing the program data

**while simultaneously holding
down two switches,
connect the power adaptor**

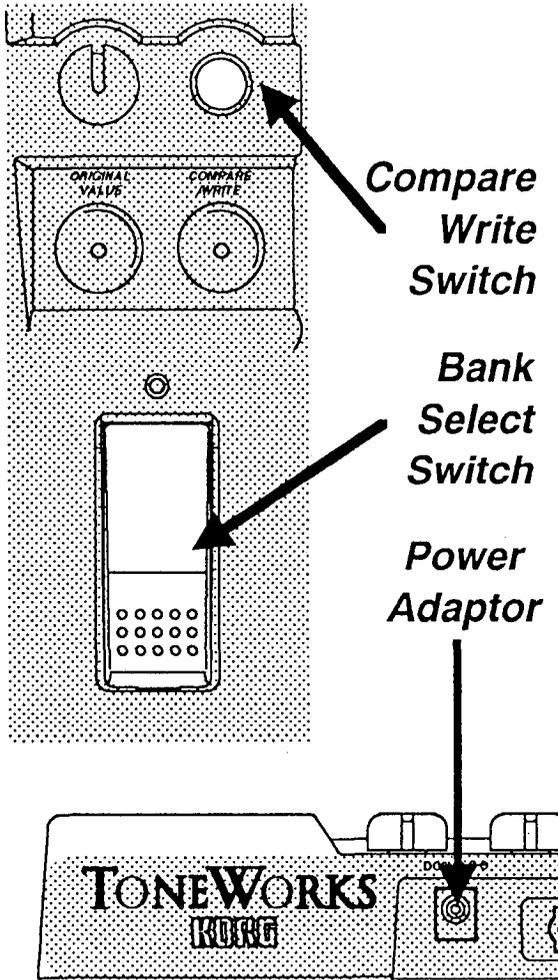

all LEDs blinking

**press the Compare/Write switch
once again**

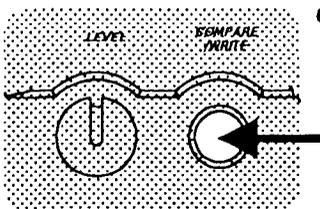

**Initialized
the factory settings are recalled**

If you wish to reset the **G5**'s memory to its factory settings, use the following procedure. This procedure is known as Initializing the program data.

While simultaneously pressing both the Compare/Write switch and the Bank Select switch, turn the power on. All LEDs will be blinking.

In this condition, press the Compare/Write switch once again. The Compare/Write LED will light, and all effect programs will be initialized to the factory settings.

(If you press any other switch, initialization will not take place, and the **G5** will resume normal operation just as if you had turned on the power as usual.)

Alternatively, you can also initialize the **G5** by turning the power on while pressing the Program 3 switch (instead of the Compare/Write switch) together with the Bank Select switch. However in this case, the data will be initialized to a different set of data than with the first method (when you use the Compare/Write switch).

In other words, depending on the switch you press together with the Bank Select switch (the Compare/Write switch or the Program 3 switch), two different sets of initial programs can be called up.

Note When you initialize the program data, all the data that you stored in internal memory using the Program Write operation will be lost.

Note When attempting to initialize the program data, if not all the LEDs blink (i.e., if they remain lit or do not turn on at all), disconnect the power and try again.

Troubleshooting

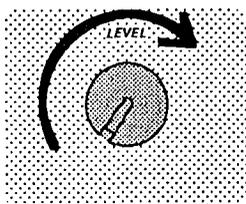
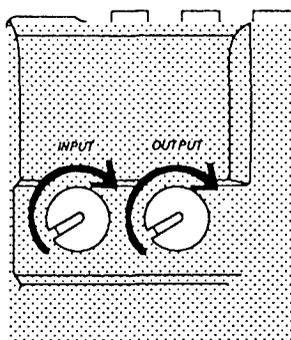

If the **G5** does not function in the way you expect, check the following points. If this does solve the problem, consult your dealer or a Korg service center.

Problem1 No sound

1. Are the *Input Volume* or *Output Volume* set to 0?
2. If a *fc pedal* is connected, is the *INTENSITY* knob set to 0 (center) and the *fc pedal* all the way down?
3. Is the *Mute* function turned on?

If a *Program LED* is *blinking rapidly*, muting is turned on. Press the *program switch* to turn muting off.

If you are using the *SYNTH* jack, there will be no sound when either *Mute* or *Bypass* is turned on.

Problem2 .. Effects are not applied.

Or, rotating the knobs does not change the sound.

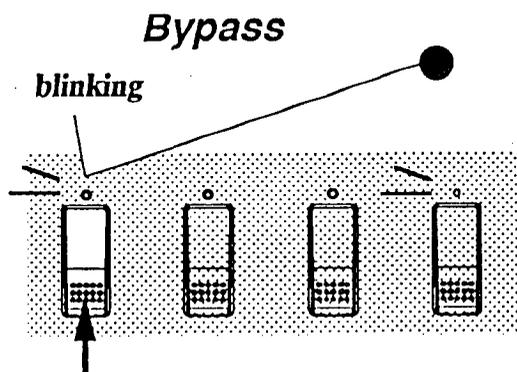

1. Is *Bypass* turned on?

If a *Program LED* is *blinking slowly*, *bypass* is turned on. Press the *program switch* to turn *bypass* off.

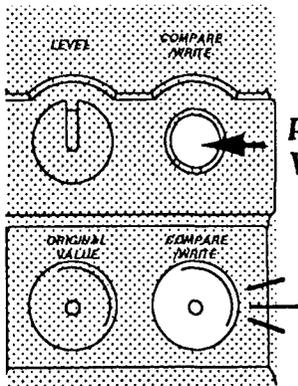

press the Compare/Write switch

2. Is Compare turned on?

If the Compare/Write LED is lit, press the Compare/Write switch to turn compare off.

3. If only the bypass sound is heard even though the Program LED is not blinking, is the MIX parameter set to the minimum position (dry 100%)?

If the MIX parameter is set to the minimum position, rotate the MIX knob to the right until you hear the effect sound.

Problem 3 All LEDs blink, and there is no sound.

The **G5** is ready to initialize the program data. Press a Program switch or the Bank Select switch to cancel initialization.

Or, disconnect and reconnect the power without pressing any switch.

Problem 4 When a parameter editor knob is rotated, the calibration markings do not match the actual effect.

The calibration markings around the edge of each parameter knob are only general indications. This means that the result you hear when rotating a knob will not always match the markings.

Specifications and options

Program	9 (3 × 3 banks)
Front panel	Knobs : Input Volume, Parameter Editor, Output Volume Switches : Bank Select switch, Compare/Write switch, Program switches LED : Waveform display, Program LED, Compare/Write LED, Bank LED, Original Value LED, Peak Indicator
Rear panel	DC9V AC adaptor jack, Input jack, Output jack (MIX, SYNTH), fc pedal jack, Headphone jack, Tuner jack
Sampling frequency	48 kHz
A/D	64 times oversampling 16bit Delta-Sigma type
D/A	8 times oversampling 18bit
Frequency response	20 Hz – 20 kHz (+ 1.5/– 3dB)
Dynamic range	90 dB (IHF-A, bypassed)
Power supply	DC 9V (with AC adaptor)
Current consumption	400 mA
Input sensitivity/ Impeadance	– 13.0 dBu – + 7.0 dBu / 1M Ω
Maximum output level/ Impeadance	+ 6.0 dBu / 5 k Ω (0dBu = 0.775Vrms)
Dimensions	280.8 (W) × 210.4 (D) × 39 (H) mm
Weight	1.1 kg
Options	VP-10, KVP-001 volume pedal

Appearance and specifications are subject to change without notice for product improvement.

NOTICE

KORG products are manufactured under strict specifications and voltages required by each country. These products are warranted by the KORG distributor only in each country. Any KORG product not sold with a warranty card or carrying a serial number disqualifies the product from the manufacturer's/distributor's warranty and liability. This requirement is for your own protection and safety.

KORG

15-12, Shimotakaido 1-chome, Suginami-ku, Tokyo, Japan

©KORG INC. 1995