

MR-16

MIDI RHYTHM SOUND UNIT

OWNER'S MANUAL

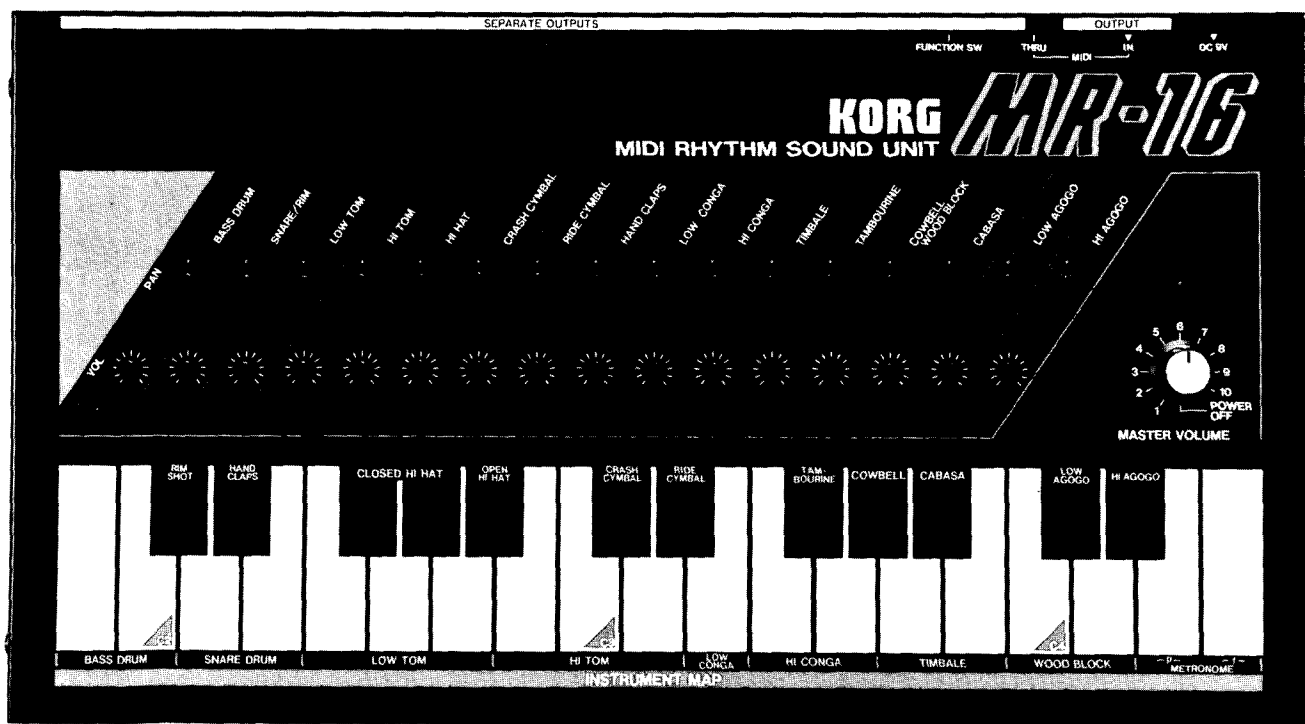

KORG®

Congratulations and thank you for purchasing the Korg MR-16. For optimum performance and long-term reliability, please read this manual carefully before operating this unit.

Major Features

- 1** Can be controlled by any MIDI keyboard, MIDI sequencer, or computer equipped with a MIDI interface. Designed exclusively for MIDI applications.
- 2** Nineteen sounds include everything in a drum kit, plus a wide variety of percussion instruments. PCM recordings of actual drum and percussion sounds are used. That means high quality and amazing realism.
- 3** Accents can be effected by MIDI data. Total volume can also be controlled.
- 4** Sixteen outputs can be connected to separate mixing console channels for independent adjustment of volume, tone, panning, and effects.
- 5** Built-in mixing facilities allow independent panning and volume adjustment of each sound sent to stereo output jacks.
- 6** Can be set to receive on any MIDI channel. Will also produce metronome sound based on MIDI timing clock.

Important Notes & Precautions

Please read and observe the following notes & precautions to assure reliability and safety.

■ LOCATION

To avoid malfunction do not use this unit in the following locations for long periods of time:

- In direct sunlight.
- Exposed to extremes of temperature or humidity.
- In sandy or dusty places.

■ HANDLE GENTLY

Knobs and switches are designed to provide positive operation with a light touch. Excessive force may cause damage.

■ MAINTENANCE

Wipe the exterior with a soft, dry cloth. Never use paint thinner, benzene or other solvents.

■ POWER SUPPLY

Use only with supplied AC adaptor. Other adaptors may cause damage or malfunction due to different voltage or polarity.

■ PREVENTING ELECTRICAL INTERFERENCE

As a microcomputer based device, the MR-16 is a precision instrument offering sophisticated features. However, computer circuitry may perform erratically if used improperly or exposed to electrical interference from other electrical devices and fluorescent lamps. Avoid operating the MR-16 near possible sources of interference. If something seems to be wrong, try turning off the power, waiting about ten seconds, then turning it back on. This resets the computer circuits to their initial state so performance should return to normal.

■ KEEP THIS MANUAL

Store this manual in a safe place for future reference.

Table of Contents

Important Notes & Precautions	3
Features & Functions	4
Connections	5
Operation	6
■ Sound sources	6
■ How it Works	6
■ Accents	7
■ Volume Control	7
■ Receive Channel Setting	8
■ Metronome Function	8
■ Typical Settings	9
Specifications/Options	10
MIDI Implementation	11

Features & Functions

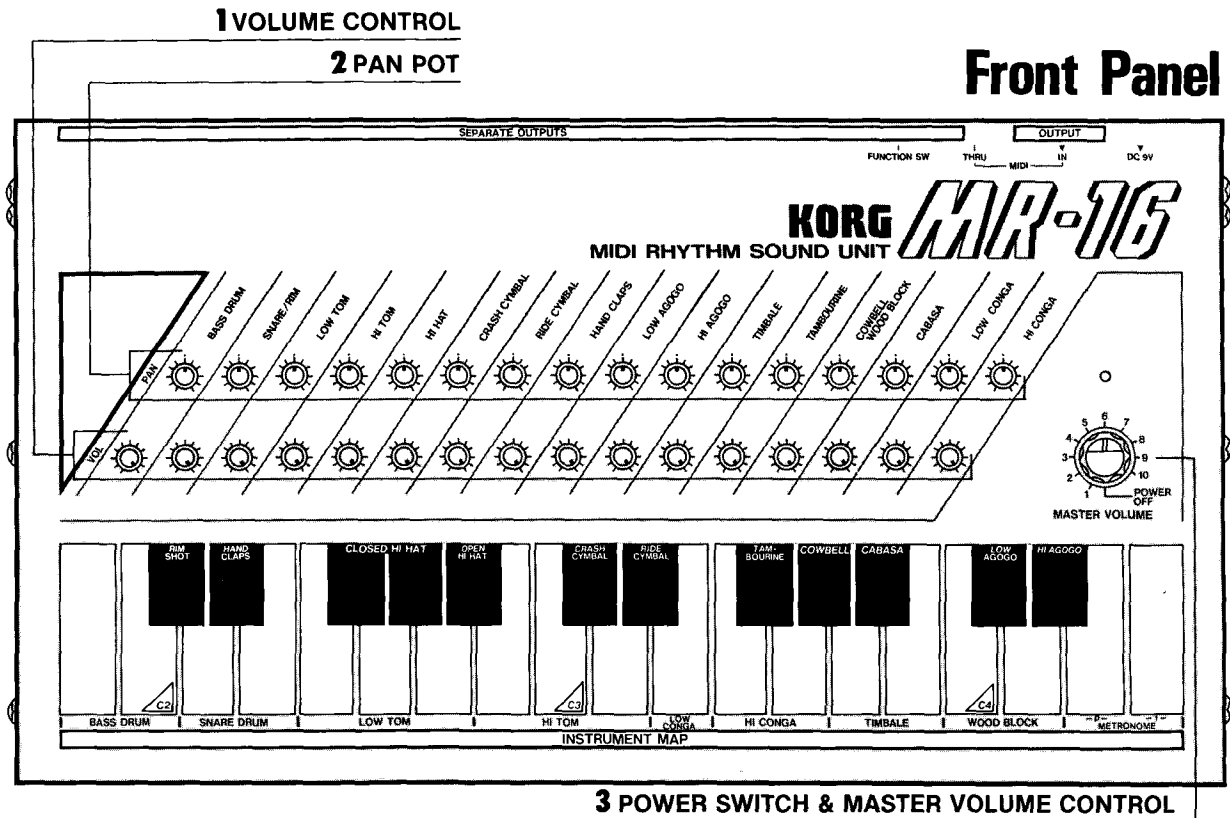

3 POWER SWITCH & MASTER VOLUME CONTROL

1 Volume control

Adjusts volume of instrument in the R & L output mix.

2 Pan pot

This lets you position the instrument in the stereo image when using the R & L output jacks.

3 Power switch & master volume control

Adjust total volume of R & L output mix. Power is turned off when this knob is turned all the way counterclockwise.

4 DC 9V input

Connect the supplied AC adaptor to this terminal.

5 MIDI IN

Input jack for MIDI signal from keyboard, sequencer, computer, etc.

6 MIDI THRU

This outputs the unchanged MIDI signal (received through the MIDI IN jack).

7 Function switches

These switches let you select functions such as the MIDI controlled metronome, the MIDI RECEIVE CHANNEL, and so on (as described in the section on FUNCTION SWITCHES.)

8 Receive channel table

Shows how to set the function switches to select particular MIDI RECEIVE CHANNEL numbers.

9 Output jacks (R, L/MONO)

Output for stereo mix, as adjusted with the pan pots and volume controls. (For mono output, use the L/MONO jack.)

10 Separate outputs

Individual outputs for each drum and percussion instrument. These can be connected to a mixing console if you want to adjust the timbre or add effects on individual sounds.

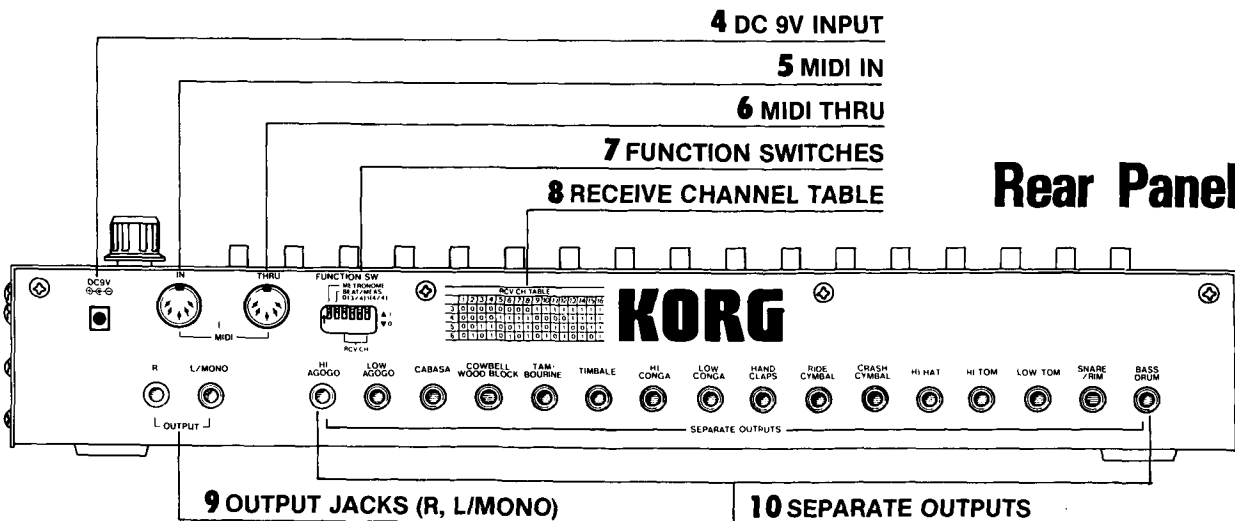

Rear Panel

Connections

Make connections in the following procedures.

1 Turn off power on MR-16 and all connected equipment.

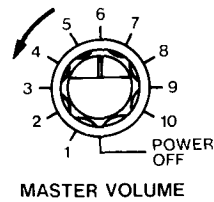

2 Connect supplied AC adaptor to rear panel DC 9V terminal. (Plug into AC wall socket.)

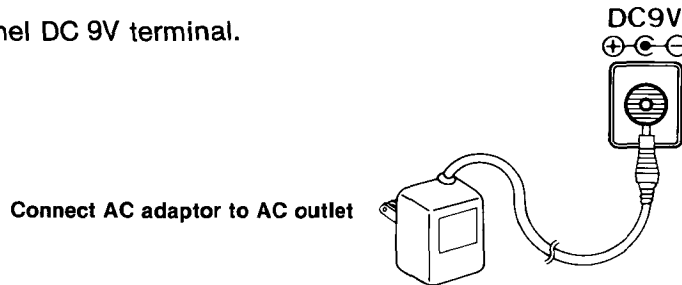

3 Connect MIDI cable (5-pin DIN cord) from MR-16 MIDI IN jack to the MIDI OUT jack of the keyboard or other MIDI unit that you will use to "play" the MR-16.

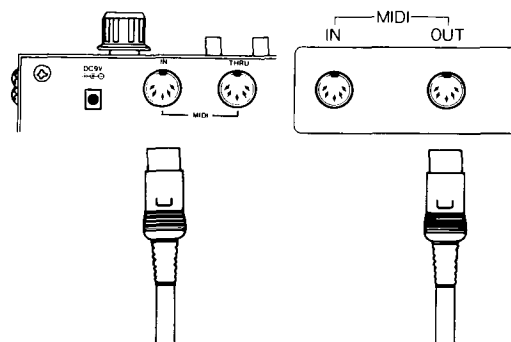

4 Connect to an amp or mixer.

1 Using the OUTPUT jacks for stereo amplification.

Connect the rear panel R & L/MONO jacks to the left and right channel AUX or TAPE IN jacks of a stereo amplifier. Or use two instrument amps. (If using only one amp, connect from the L/MONO jack.)

- Use the MR-16 PAN POT and VOLUME controls to adjust each instrument's relative volume and position in the stereo image.

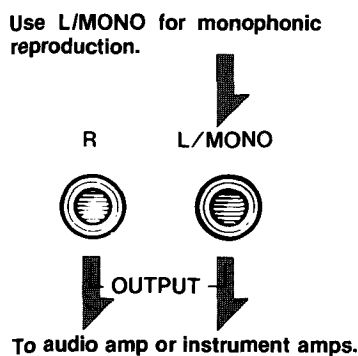

2 Connection to a mixing console.

Use the rear panel SEPARATE OUTPUT jacks to connect to individual input channels on a mixing console.

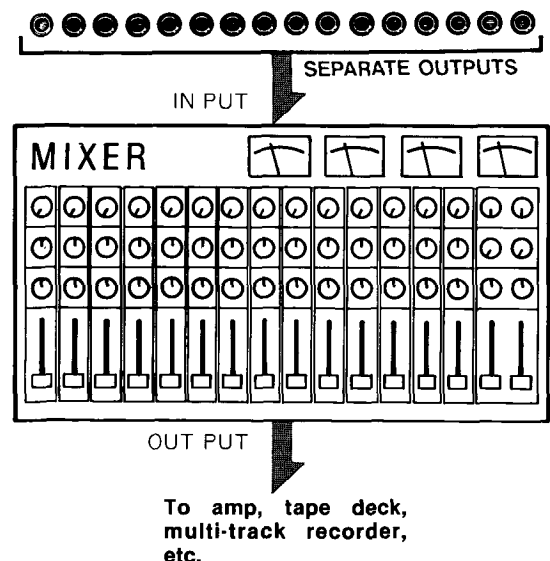

- SEPARATE OUTPUT signal level is fixed (not affected by MR-16 volume controls). Use mixing console controls to adjust volume, tone, and position in the stereo image.

5 Lower the output levels of the amplifier and mixer and, after confirming that everything is properly connected, turn on the power on the MR-16 and other equipment.

Operation

The Korg MR-16 MIDI Rhythm Sound Unit is designed to be controlled (played)

■ **Sound Sources** The MR-16 has the following 19 drum and percussion sounds (21, if you include the metronome).

Drum Kit Sounds	
● Bass drum	● High tom
● Rimshot	● Closed hi-hat
● Snare drum	● Open hi-hat
● Handclaps	● Crash cymbal
● Low tom	● Ride cymbal

Percussion Sounds	
● Low conga	● Cabasa
● High conga	● Woodblock
● Tambourine	● Low agogo
● Cowbell	● High agogo
● Timbale	● Metronome (P)(f)

These are all digital PCM recordings of real instrument sounds, your assurance of quality and realism.

■ How it Works

The MR-16 produces drum sounds when it receives MIDI "note data." Each drum/percussion sound corresponds to a particular MIDI "note number" (Specifically, the MR-16 responds to "note on events," a kind of data which includes the note number and velocity.)

The charts below show how keyboard notes and MIDI data correspond with MR-16 drum/percussion sounds.

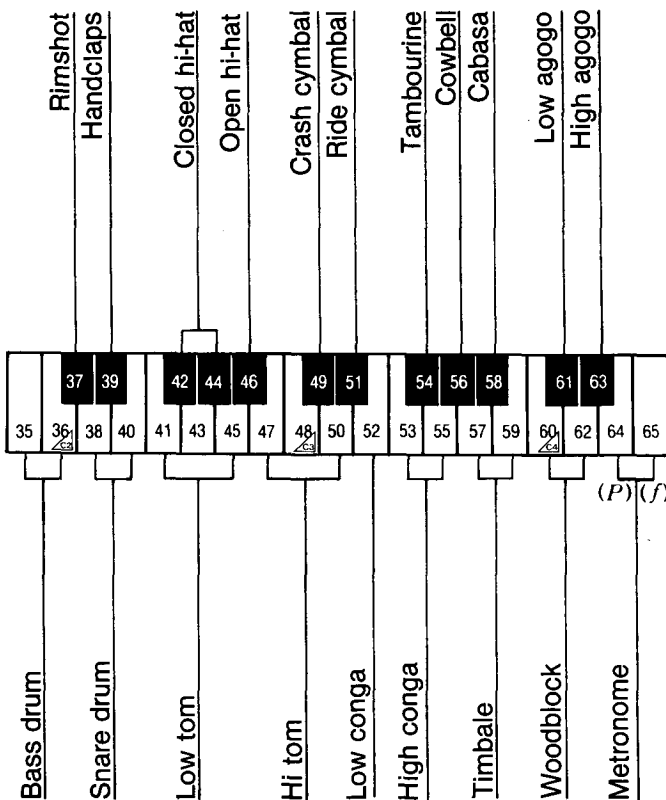

Drum/percussion sound	Note number ("H" is hexadecimal, bracketed numbers are decimal)
Bass drum	23 (H) [35], 24 (H) [36]
Rimshot	25 (H) [37]
Snare drum	26 (H) [38], 28 (H) [40]
Handclaps	27 (H) [39]
Low tom	29 (H) [41], 2B (H) [43], 2D (H) [45]
High tom	2F (H) [47], 30 (H) [48], 32 (H) [50]
Closed hi-hat	2A (H) [42], 2C (H) [44]
Open hi-hat	2E (H) [46]
Crash cymbal	31 (H) [49]
Ride cymbal	33 (H) [51]
Low conga	34 (H) [52]
High conga	35 (H) [53], 37 (H) [55]
Tambourine	36 (H) [54]
Cowbell	38 (H) [56]
Timbale	39 (H) [57], 3B (H) [59]
Cabasa	3A (H) [58]
Woodblock	3C (H) [60], 3E (H) [62]
Low agogo	3D (H) [61]
High agogo	3F (H) [63]
Metronome	40 (H) [64] Piano, 41 (H) [65] forte

The MR-16 ignores note number data other than that shown in the chart.

The following sounds can not be played simultaneously.

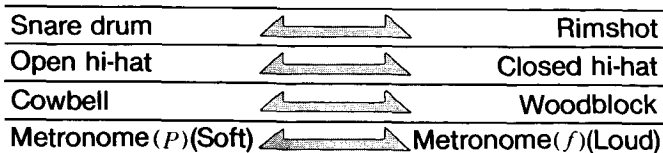

Example: Using the Korg RK-100 remote keyboard to play the MR-16.

Set the MR-16's MIDI receive channel to 1. (For details, see section on receive channel setting.) The RK-100 has an octave selector which can be set to any of three

positions, marked L (note numbers 36 ~ 76), M (48 ~ 88), H (60 ~ 100). Set the RK-100 octave switch to the L position when using it to play the MR-16.

Note number range and RK-100 octave switch setting.

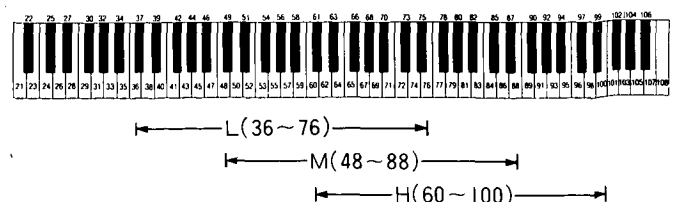

Here, low C (note number 36) on the RK-100 is the bass drum and the next higher C (note number 48) is the high tom.

by MIDI data from a remote keyboard, synthesizer, sequencer, or computer.

■ Accents

MIDI velocity data can be used to accent particular sounds. When using a velocity sensitive (touch sensitive) MIDI keyboard, you can control MR-16 drum/percussion volume by how hard you play the keys. There are two volume levels; depending on how hard you play, you will get either the usual volume or the accented sound.

How keys are played	Normal	Hard
Velocity data	O1-5F (H)	60 (H) or more
MR-16 accent	Normal volume	Accented sound

■ Volume Control

There are three ways to control the volume of the sound from the rear panel OUTPUT jacks (R, L/MONO).

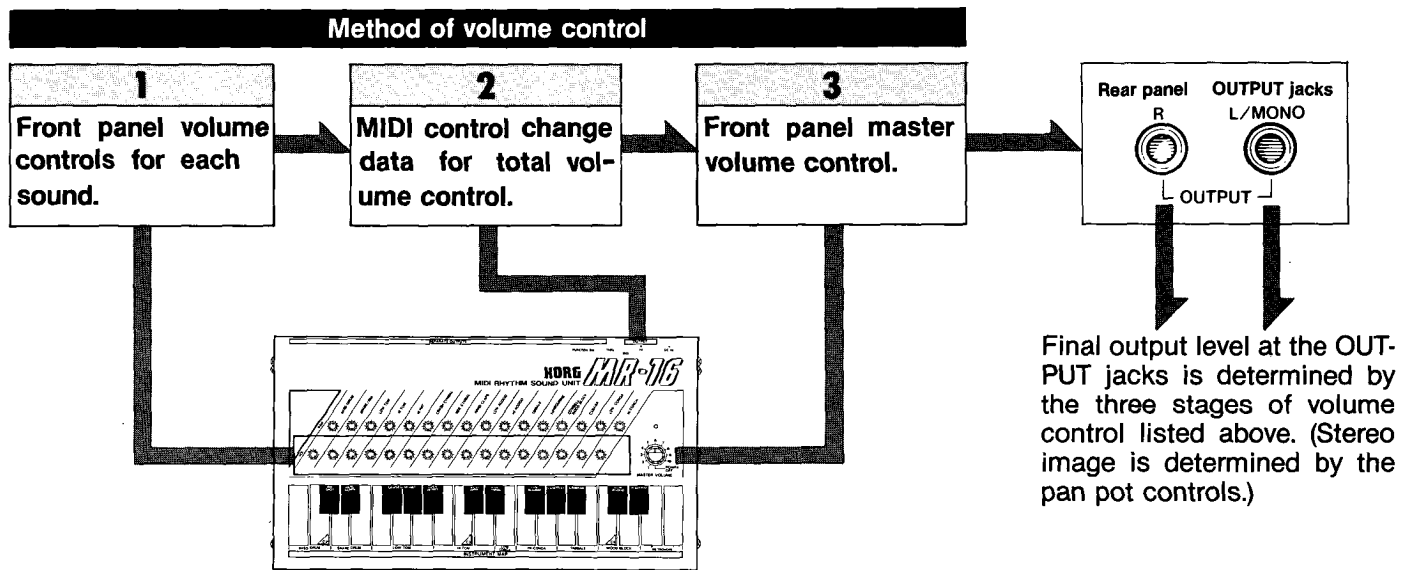

Caution:

- Volume can be controlled via MIDI only if the MIDI control unit (synth, etc.) has MIDI volume control capability. If this capability exists, then no sound will be heard from the MR-16 when the control change data is at the minimum value, regardless of the position of the master volume control.
- As long as the MR-16 does not receive control change data (or the controlling MIDI unit is without such capability), then MR-16 internal volume is set to the maximum when power is turned on. Use the front panel master volume control to make overall adjustment.

- SEPARATE OUTPUT levels are fixed, except for MIDI controlled accents. These outputs are provided if you want to use a separate mixing console for more control over individual sounds. (Signal level is not affected by MIDI control change or MR-16 volume controls.)

Control Change Data
 MIDI control change #7 is used when changing volume. Other control numbers are ignored. (For details, see MR-16 MIDI implementation). This value is set to the maximum when MR-16 power is turned on.

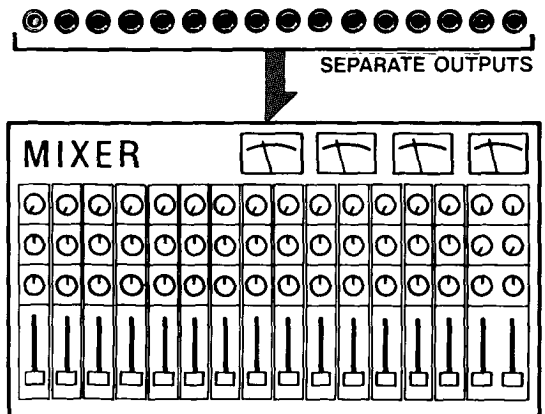

Receive Channel Setting

The MR-16 can be set to receive any single MIDI channel from 1 through 16. To select a "MIDI receive channel," set the MR-16 rear panel function switches (3~6) according to the chart shown here.

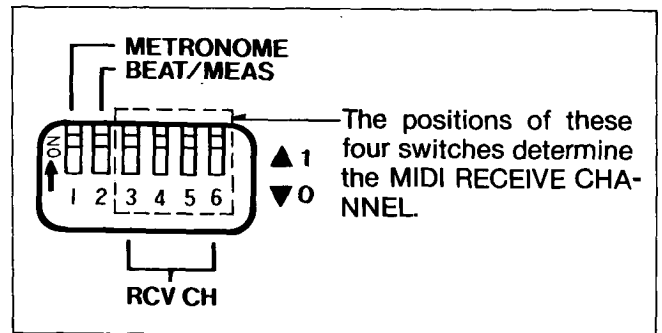

RECEIVE CHANNEL	1	2	3	4	5	6	7	8	9	10	11	12	13	14	15	16
FUNCTION SWITCH (3~6) SETTINGS	□□□□	□□□□	□□□□	□□□□	□□□□	□□□□	□□□□	□□□□	□□□□	□□□□	□□□□	□□□□	□□□□	□□□□	□□□□	□□□□

① Find the number of the MIDI channel that you want to receive.

② Read the switch settings.

RCV CH TABLE	
	1 2 3 4 5 6 7 8 9 10 11 12 13 14 15 16
3	0 0 0 0 0 0 0 0 1 1 1 1 1 1 1 1
4	0 0 0 0 1 1 1 1 0 0 0 0 1 1 1 1
5	0 0 1 1 0 0 1 1 0 0 1 1 0 0 1 1
6	0 1 0 1 0 1 0 1 0 1 0 1 0 1 0 1

On the rear panel of the MR-16 is a chart called the "RCV CH TABLE" which shows how to set the function switches to receive particular channels. A "0" means OFF (□); a "1" means ON (■).

Example: To set to MIDI channel 7.

RCV CH TABLE	
	6 7 8
3	0 0 0
4	1 1 1
5	0 1 1
6	1 0 1

Function switch settings are:

- 3 → 0
- 4 → 1
- 5 → 1
- 6 → 0

Metronome Function

The MR-16 metronome sounds can be activated in two ways, as described below.

1 Metronome activated by reception of MIDI note number.

The metronome sounds correspond with MIDI note numbers 40 (H) and 41 (H) (decimal 64, 65). The MR-16 will sound the metronome when it receives "note on event" data for these note numbers.

2 Metronome activated by MIDI clock signal.

If the first (number 1) function switch is turned on (up), then the MR-16 will automatically generate metronome sounds (4/4 or 3/4) according to the received MIDI clock signal.

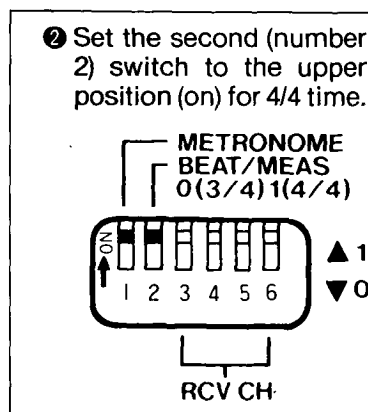
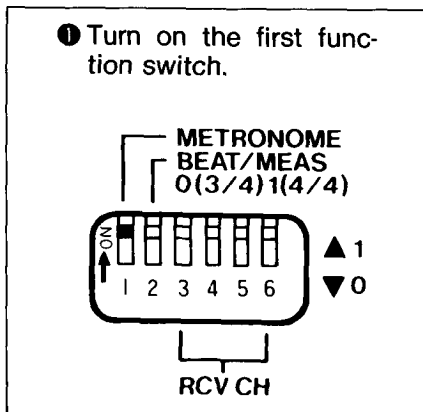

For 3/4 time, turn the second switch off (lower position).

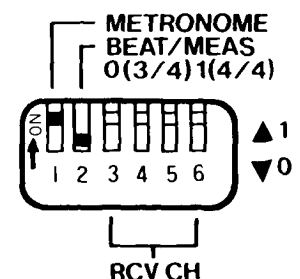

● The metronome sound is only available through the rear panel OUTPUT (R & L/MONO) jacks.

■ Typical/Settings

Using a MIDI sequencer to control the MR-16.

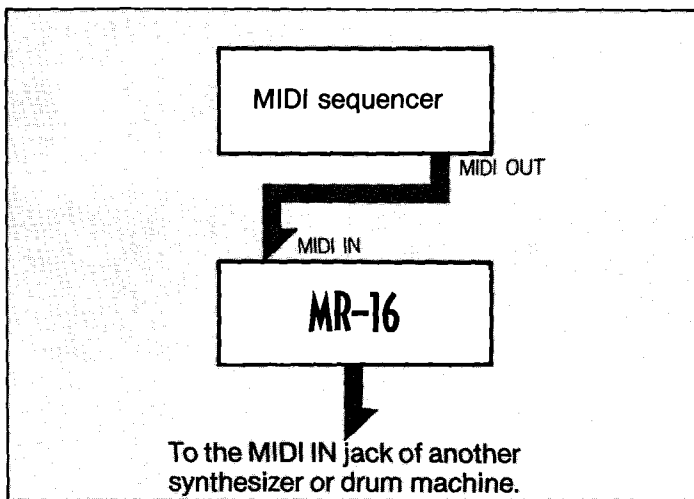

The MR-16 is controlled by the sequencer which stores "note data" as a rhythm pattern.

Using a MIDI synthesizer or remote keyboard to control the MR-16.

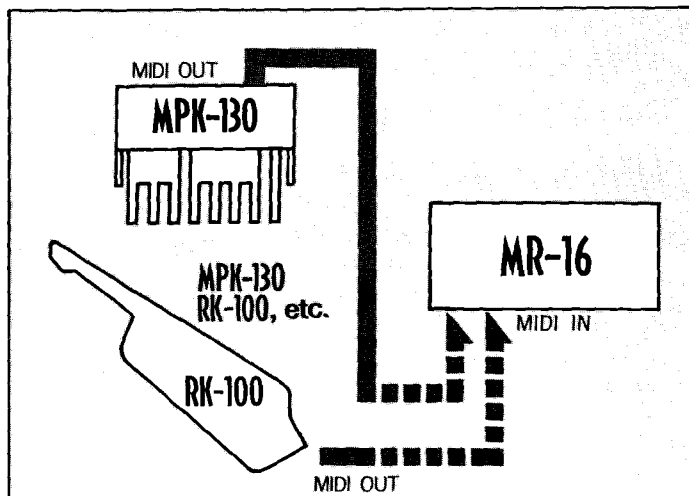

When you play notes on the keyboard, the corresponding drum/percussion sounds are reproduced on the MR-16. In other words, you can play drums and percussion from the keyboard.

Using a computer with MIDI interface to control the MR-16.

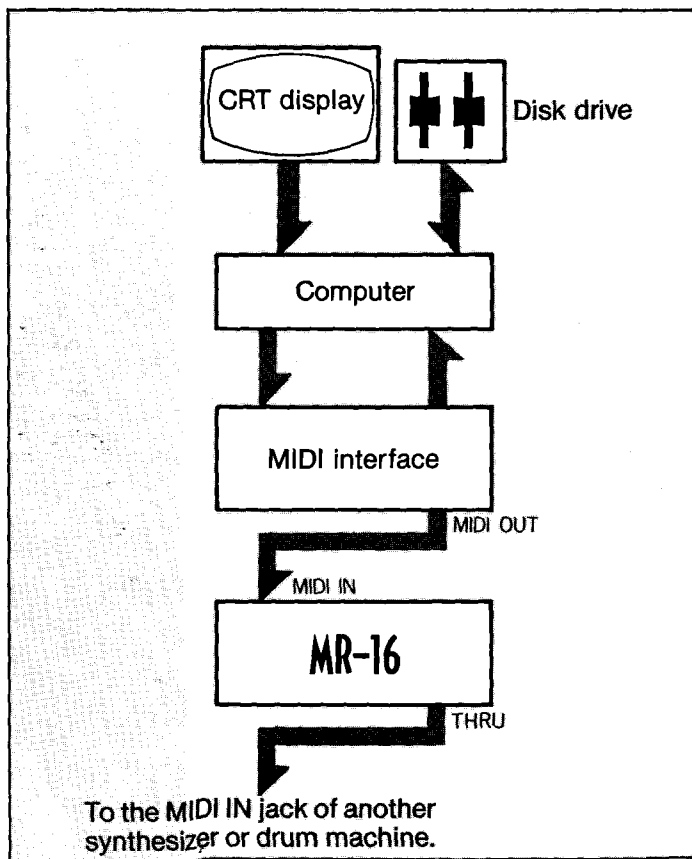

Using MIDI software, the computer controls the MR-16 according to data stored on disk.

Using a synth with built-in sequencer to program rhythms into a sequencer capable of being programmed directly.

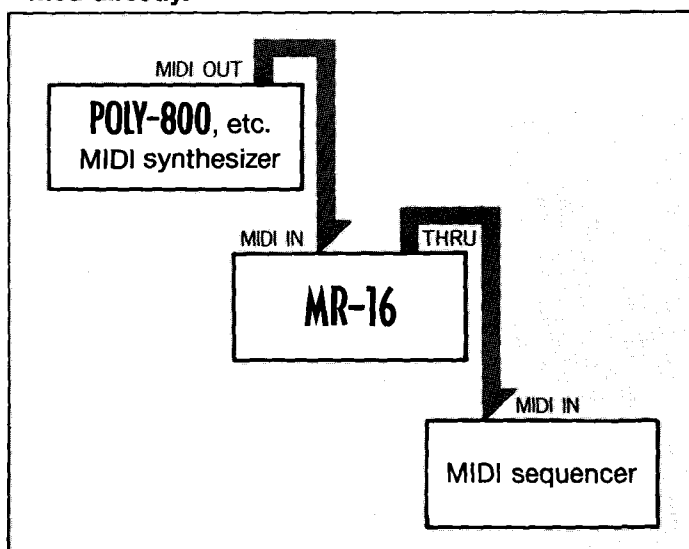

- ① Connect as shown above.
- ② Set MR-16 receive channel and MIDI synth send channel so they match.
- ③ Set sequencer to external clock mode and turn on MIDI synth's built-in sequencer.
- ④ Playing the MIDI synth causes the MR-16 to generate rhythm sounds; the corresponding note numbers are written into the external sequencer. This is a useful system since it lets you hear the drum/percussion sounds as you write them. It helps to use the metronome function in this situation. The metronome function is conveniently used for this operation.

● Please refer to the MR-16 MIDI Implementation notes for details concerning MIDI data.

Specifications/Options

- **TONE GENERATORS:** Bass Drum, Snare Drum/Rim Shot, Low Tom, High Tom, Closed High-Hat/ Open High-Hat, Crash Cymbal, Ride Cymbal, Handclaps, Low Conga, High Conga, Timbale, Tambourine, Cowbell/Woodblock, Cabasa, Low Agogo, High Agogo, (Metronome)
- **CONTROL:** Volume, Pan Pot, Master Volume
- **FUNCTION SWITCH:** Metronome Function ON/OFF, Metronome-time Settings (4/4, 3/4)
- **INPUT:** MIDI IN
- **OUTPUTS:** MIDI THRU, Outputs (R, L/MONO), Separate Outputs (Bass Drum, Snare Drum/Rim Shot, Low Tom, High Tom, High-Hat, Crash Cymbal, Ride Cymbal, Handclaps, Low Conga, High Conga, Timbale, Tambourine, Cowbell/ Woodblock, Cabasa, Low Agogo, High Agogo)
- **POWER SUPPLY:** DC 9V 300mA (AC Adaptor)
- **DIMENSIONS:** 404(W) × 220(D) × 69(H) mm
- **WEIGHT:** 2.5 kg
- **SUPPLIED ACCESSORIES:** AC Adaptor, MIDI Cable (1.5 m)
- **OPTION:** Soft Case, Signal Cord

N O T I C E

Korg products are manufactured under strict specifications and voltages required by each country. These products are warranted by the Korg distributor only in each country. Any Korg product not sold with a warranty card or carrying a serial number disqualifies the product sold from the manufacturer's/distributor's warranty and liability. This requirement is for your own protection and safety.

MIDI Implementation

RECOGNIZED RECEIVE DATA 1

STATUS	SECOND	THIRD	DESCRIPTION
1 0 0 1 n n n n	0 k k k k k k k	0 v v v v v v v	NOTE ON SEE TABLE 1 NOTE 1
1 0 0 1 n n n n	0 k k k k k k k	0 0 0 0 0 0 0	NOTE OFF NOTE 2
1 0 1 1 n n n n	0 0 0 0 0 1 1 1	0 v v v v v v v	VOLUME CONTROL NOTE 3

RECOGNIZED RECEIVE DATA 2

STATUS	SECOND	THIRD	DESCRIPTION
1 1 1 1 1 0 0 0	_____	_____	TIMING CLOCK (F8) NOTE 4
1 1 1 1 1 0 1 0	_____	_____	START (FA)
1 1 1 1 1 0 1 1	_____	_____	STOP (FC)
1 1 1 1 1 0 1 1	_____	_____	CONTINUE START (FB)

TABLE 1

NOTE No.	INSTRUMENTS	No.	INSTRUMENTS	No.	INSTRUMENTS
35	BASS DRUM	46	OPEN HI HAT	56	COWBELL
36	BASS DRUM	47	HI TOM	57	TIMBALES
37	RIM SHOT	48	HI TOM	58	CABASA
38	SNARE DRUM	49	CRASH CYM.	59	TIMBALES
39	HAND CLAPS	50	HI TOM	60	WOOD BLOCK
40	SNARE DRUM	51	RIDE CYM.	61	LOW AGOGO
41	LOW TOM	52	LOW CONGA	62	WOOD BLOCK
42	CLOSED HI HAT	53	HI CONGA	63	HI AGOGO
43	LOW TOM	54	TAMBOURINE	64	METRONOME(<i>P</i>)
44	CLOSED HI HAT	55	HI CONGA	65	METRONOME(<i>f</i>)
45	LOW TOM				

NOTES

- 1** A sound is accented when its velocity value is 96 or higher. vvvvvvv ≠ 0000000
- 2** If the NOTE OFF signal is received, the MR-16 will not stop sound outputs.
- 3** Volume control resolution is 7-bit, with the least significant bit ignored.
- 4** The timing clock data can be received in the interval between a start message and a stop message.

KORG[®]

KEIO ELECTRONIC LABORATORY CORPORATION
15-12, Shimotakaido 1-chome, Suginami-ku, Tokyo, Japan.

©KEIO ELECTRONIC LABORATORY CORP. 1985

6002 ETH PRINTED IN JAPAN